

AMA Specifications – Passenger Car

The information contained herein is prepared, distributed by, and is solely the responsibility of the automobile manufacturing company to whose products it relates. Questions concerning these specifications should be directed to the manufacturer whose address is shown below. This uniform specification form was developed by the automobile manufacturing companies under the auspices of the Automobile Manufacturers Association.

MANUFACTURER	Oldsmobile Division General Motors Corp.	CAR NAME	Oldsmobile
MAILING ADDRESS	Lansing 21, Michigan	MODEL YEAR	1963
		ISSUED:	9-1-62
		REVISED (•)	

NOTES:

1. The Specifications herein are those in effect at date of compilation and are subject to change without notice by the manufacturer.
2. UNLESS OTHERWISE INDICATED:
 - a. Specifications apply to standard models without optional equipment. Significant deviations are noted.
 - b. Nominal design dimensions are used throughout these specifications.

TABLE OF CONTENTS

General Specifications 1	Drive Units 15	Rear Suspension 21	Body & Car - General 22
Engine - Mechanical 2	Brakes 18	Body Dimensions 22	Weights 33
Electrical 10	Front Suspension & Steering . . 19	Station Wagon 31	Index 37

BODY—TYPES AND STYLE NAMES—		Body type, number of passenger & style names; use manufacturer's code for series & body style.			
Body Type	No. of Passengers	"88"	Super "88"	Starfire "	"98"
4 Door Sedan	6	3269	3569	-	3819
4 Door Hardtop Sedan (4 Window)	6	3239	3539	-	3839
4 Door Hardtop Sedan (6 Window)	6	-	-	-	3829
2 Door Hardtop Coupe	6	3247	3547	3657 *	3847
2 Door Sport Coupe	5	-	-	-	3947
2 Door Convertible Coupe	5	3267	-	3667	3867
4 Door Station Wagon 2-seat	6	3235	3535	-	-
4 Door Station Wagon 3-seat	9	3245	-	-	-
* Passenger Capacity is 5 - Bucket Front Seats Std. Equipment.					

AMA Specifications – Passenger Car

MAKE OF CAR OLDSMOBILE MODEL YEAR 1963 DATE ISSUED 9-1-62 REVISED()

GENERAL SPECIFICATIONS

(All dimensions in inches unless otherwise indicated)

MODEL		Additional Information Page No.:	3239	3247	3267	3269	3235-45	3539	3547	3569
Wheelbase (L101)		23	123.0	123.0	123.0	123.0	123.0	123.0	123.0	123.0
Tread	Front (W101)	22	62.2	62.2	62.2	62.2	62.2	62.2	62.2	62.2
	Rear (W102)	22	61.0	61.0	61.0	61.0	61.0	61.0	61.0	61.0
Maximum Overall Dimensions	Length (L103)	23	214.5	214.5	214.5	214.5	214.5	214.5	214.5	214.5
	Width (W103)	22	77.9	77.9	77.9	77.9	77.9	77.9	77.9	77.9
	Height (H101)	24	55.6	55.2	55.9	56.3	58.1	55.6	55.2	56.3
Transmission— (Specify trade name - opt., not available)	Manual	15	Std.	Std.	Std.	Std.	Std.	Std.	Std.	Std.
	Overdrive	16	NA	NA	NA	NA	NA	NA	NA	NA
	Automatic	16	Opt.	Opt.	Opt.	Opt.	Opt.	Opt.	Opt.	Opt.
Axle ratio	Manual	17	3.23	3.23	3.23	3.23	3.23	3.23	3.23	3.23
	Overdrive	17	None	None	None	None	None	None	None	None
	Automatic	17	2.56	2.56	2.56	2.56	2.69	2.87	2.87	2.87
Tire size		18	8.00 x 14	8.00 x 14	8.00 x 14	8.00 x 14	8.00 x 14	8.00 x 14	8.00 x 14	8.00 x 14
Engine	Type, no. cyl., valve arr.	2	90° V-8 O. H. V.							
	Fuel system (Carb., other)	8	Carburetor							
	Bore and stroke	2	4.125 x 3.688							
	Piston displ., cu.in.	2	394	394	394	394	394	394	394	394
	Std. compression ratio	2	10.25:1	10.25:1	10.25:1	10.25:1	10.25:1	10.25:1	10.25:1	10.25:1
	Max. bhp at engine rpm	2	280@ 4400	280@ 4400	280@ 4400	280@ 4400	280@ 4400	330@ 4600	330@ 4600	330@ 4600
	Max. torque at rpm	2	430@ 2400	430@ 2400	430@ 2400	430@ 2400	430@ 2400	440@ 2800	440@ 2800	440@ 2800

AMA Specifications – Passenger Car

MAKE OF CAR OLDSMOBILE MODEL YEAR 1963 DATE ISSUED 9-1-62 REVISED(•) _____

GENERAL SPECIFICATIONS

(All dimensions in inches unless otherwise indicated)

MODEL		Additional Information Page No.:	3535	3657	3667	3819	3829	3839	3847	3867	3947
Wheelbase (L101)		23	123.0	123.0	123.0	126.0	126.0	126.0	126.0	126.0	126.0
Tread	Front (W101)	22	62.2	62.2	62.2	62.2	66.2	62.2	62.2	62.2	62.2
	Rear (W102)	22	61.0	61.0	61.0	61.0	61.0	61.0	61.0	61.0	61.0
Maximum Overall Dimensions	Length (L103)	23	214.5	214.5	214.5	221.7	221.7	221.7	221.7	221.7	221.7
	Width (W103)	22	77.9	77.9	77.9	77.9	77.9	77.9	77.9	77.9	77.9
	Height (H101)	24	58.1	55.0	55.9	57.1	57.1	55.1	55.8	55.8	55.1
Transmission— (Specify trade name - opt., not available)	Manual	15	Std.	NA	NA	NA	NA	NA	NA	NA	NA
	Overdrive	16	NA	NA	NA	NA	NA	NA	NA	NA	NA
	Automatic	16	Opt.	Std.	Std.	Std.	Std.	Std.	Std.	Std.	Std.
Axle ratio	Manual	17	3.23	NA	NA	NA	NA	NA	NA	NA	NA
	Overdrive	17	None	None	None	None	None	None	None	None	None
	Automatic	17	3.08	3.42	3.42	3.08	3.08	3.08	3.08	3.08	3.42
Tire size		18	8.00 x 14	8.00 x 14	8.50 x 14	8.50 x 14	8.50 x 14	8.50 x 14	8.50 x 14	8.50 x 14	8.50 x 14
Engine	Type, no. cyl., valve arr.	2			90°	V-8	O. H. V.				
	Fuel system (Carb., other)	B				Carburetor					
	Bore and stroke	2			4.125	x	3.688				
	Piston displ., cu.in.	2	394	394	394	394	394	394	394	394	394
	Std. compression ratio	2	10.25:1	10.50:1	10.50:1	10.25:1	10.25:1	10.25:1	10.25:1	10.25:1	10.50:1
	Max. bhp at engine rpm	2	330@ 4600	345@ 4800	345@ 4800	330@ 4600	330@ 4600	330@ 4600	330@ 4600	330@ 4600	345@ 4800
	Max. torque at rpm	2	440@ 2800	440@ 3200	440@ 3200	440@ 2800	440@ 2800	440@ 2800	440@ 2800	440@ 2800	440@ 3200

AMA Specifications—Passenger Car

MAKE OF CAR Oldsmobile MODEL YEAR 1963 DATE ISSUED 9-1-62 REVISED ^(*)

MODEL	3200	3500 & 3800	3600 & 3900
--------------	------	-------------	-------------

ENGINE—GENERAL

Type, no. cyls., valve arr.		90° V8 O. H. V.	
Bore and stroke (nominal)		4.125 x 3.688	
Piston displacement, c.u. in.		394	
Bore spacing (C/L to C/L)		4.625	
No. system (front to rear)	L. Bank	1 - 3 - 5 - 7	
	R. Bank	2 - 4 - 6 - 8	
Firing order		1 - 8 - 7 - 3 - 6 - 5 - 4 - 2	
Compres. ratio (nominal)		10.25:1	10.50:1
Cylinder Head Material		Cast Iron	
Cylinder Block Material		Cast Iron	
Cylinder Sleeve—Wet, dry, none		None	
Number of mounting points	Front	One	
	Rear	Two	
Engine installation angle		Standard Transmission: 4° 30' Hydramatic: 4°	
Taxable horsepower	$\frac{\text{Dia.}^2 \times \text{No. Cyl.}}{2.5}$	54	
Published max. bhp* @ eng. RPM	280 @ 4400	330 @ 4600	345 @ 4800
	430 @ 2400	440 @ 2800	440 @ 3200
Recommended fuel regular - premium		Premium	
Idle speed (spec. neutral or drive)	Manual	550	650
	Automatic	500	600

ENGINE—PISTONS

Material		Aluminum Alloy		
Description and finish		Autothermic, Cam Grind, Tin Plate, Steel Strut		
Weight (piston only) oz.		26.349		
Clearance (limits)	Top land	.028 - .034		
	Skirt	Top	.00075 - .00225	
		Bottom	.00075 - .00125	
Ring groove depth	No. 1 ring	.2125 - .2195		
	No. 2 ring	.2125 - .2195		
	No. 3 ring	.2045 - .2075		
	No. 4 ring	None		

* Max. bhp (brake horsepower) and max. torque corrected as defined by SAE Engine Test Code.

AMA Specifications – Passenger Car

MAKE OF CAR Oldsmobile **MODEL YEAR** 1963 **DATE ISSUED** 9-1-62 **REVISED** (*)

POWER TEAMS

(Indicate whether standard or optional)

MODEL AVAILABILITY	ENGINE					TRANSMISSION	AXLE RATIO (Std. first)
	Displ. cu. in.	Carburetor	Compr. Ratio	BHP @ RPM	Torque @ RPM		
3200 (Std.)	394	2 bbl.	10.25:1	280@	430@	Synchronesh	3.23:1
				4400	2400	Hydra-Matic	2.56:1
3200(Opt.)	394	2 bbl.	8.75:1	260@	410@	Synchronesh	3.23:1
				4400	4400	Hydra-Matic	2.69:1
3200 (Opt.)	394	4 bbl.	10.25:1	330@	440@	Synchronesh	3.23:1
				4600	2800	Hydra-Matic	2.87:1
3500 (Std.)	394	4 bbl.	10.25:1	330@	440@	Synchronesh	3.23:1
				4600	2800	Hydra-Matic	2.87:1
3600 & 3900 (Std.)	394	4 bbl.	10.50:1	345@ 4800	440@ 3200	Hydra-Matic	3.42:1
3800 (Std.)	394	4 bbl.	10.25:1	330@ 4600	440@ 2800	Hydra-Matic	3.08:1

AMA Specifications – Passenger Car

MAKE OF CAR Oldsmobile MODEL YEAR 1963 DATE ISSUED 9-1-62 REVISED (a)

MODEL 3200 3500 & 3800 3600 & 3900

ENGINE—RINGS

Function (top to bottom)	No. 1, oil or comp.		Compression
	No. 2, oil or comp.		Compression
	No. 3, oil or comp.		Oil
	No. 4, oil or comp.		None
Compression	Description - material, type, coating, etc.	Cast Iron - Upper Ring: Chrome Plated O. D. - Tape Face Lower Ring: Parco-Lubrited-Taper Face - Interrupted Scraper Groove	
	Width	#1: .0775 - .0780	#2: .0925 - .0935
	Gap	.013 - .023	
Oil	Description - material, type, coating, etc.	Spring Steel - Two Rails: Chrome Plated O. D. Spacer: Black Oxide	
	Width	Rails: .0235 - .0250 Each	Spacer: .177 - .182
	Gap	.015 - .055	
Expanders		None	

ENGINE—PISTON PINS

Material	S. A. E. #1016 Special		
Length	3.126		
Diameter	.9803 - .9807		
Type	Locked in rod, in piston, floating, etc.		Full Floating
	Bushing	In rod or piston	Rod
		Material	G. M. #4077 - M Bronze
Clearance	In piston	.0003 - .0005 Loose	
	In rod	.0003 - .0005 Loose	
Direction & amount offset in piston	.090 to R. H. of Cylinder Bore Centerline		

ENGINE—CONNECTING RODS

Material	Steel - S. A. E. # 1139		
Weight (oz.)	34.55 oz.		
Length (center to center)	6.998		
Bearing	Material & Type		Moraine 400 Aluminum with G. M. 3874 Babbitt Overlay - Steel Backed
	Overall length		.821 - .831
	Clearance (limits)		.0005 - .0025
	End play		(.004 to .009 Preferred) .002 - .011 - 2 Rods per Crankpin

AMA Specifications—Passenger Car

MAKE OF CAR Oldsmobile **MODEL YEAR** 1963 **DATE ISSUED** 9-1-62 **REVISED** (a)

MODEL 3200 3500 & 3800 3600 & 3900

ENGINE—CRANKSHAFT

Material		S. A. E. #1145 Modified or S. A. E. #1046		
Vibration damper type		Rubber Absorption		
End thrust taken by bearing (No.)		Rear - Upper & Lower		
Crankshaft end play		.004 - .008		
Main bearing	Material & type	#1-2-3-4: Steel Backed Aluminum Moraine 400 with G.M. 3874-M Babbitt Overlay #5(Rear: Steel Backed Durex 100A with G.M. 4176-M Babbitt Overlay		
	Clearance	#1 & 2: .0005 - .0021 #3&4: .0008-.0024 #5 Rear .0020-.0034		
	Journal dia. and bearing overall length	No. 1	3.00 x 1.068	
		No. 2	3.00 x .818	
		No. 3	3.00 x .818	
		No. 4	3.00 x .818	
		No. 5	3.00 x 1.690	
		No. 6	None	
No. 7		None		
Dir. & amt. cyl. offset		None		
Crankpin journal diameter		2.50		

ENGINE—CAMSHAFT

Location		Center	
Material		Alloy Cast Iron	
Bearings	Material	Steel Backed G.M. 4195-M Babbitt	
	Number	5	
Gear or chain		Chain	
Crankshaft gear or sprocket material		S. A. E. #1140, 1118, 1146, G.M. 85M Steel or A. S. T. M. B-310 Sintered Iron	
Type of Drive	Camshaft gear or sprocket material		Cast Iron
	Timing chain	No. of links	48
		Width	.844
		Pitch	.500

ENGINE—VALVE SYSTEM

Hydraulic lifters (Std, opt, NA)		Standard	
Valve rotator, type (intake, exhaust)		None	
Rocker ratio		1.8 : 1	
Operating tappet clearance (indicate hot or cold)	Intake	None	
	Exhaust	None	
Timing marks on flywheel, damper, other		Camshaft Sprocket & Crankshaft Sprocket	

(Continued)

AMA Specifications--Passenger Car

MAKE OF CAR Oldsmobile MODEL YEAR 1963 DATE ISSUED 9-1-62 REVISED(*)

MODEL 3200 3500 & 3800 3600 & 3900

ENGINE--VALVE SYSTEM (cont.)

Timing	Intake	Opens (°BTC)	14	11	21	
		Closes (°ABC)	50	59	77	
		Duration - deg.				
	Exhaust	Opens (°BBC)	54	59	60	
		Closes (°ATC)	16	25	20	
		Duration - deg.				
Valve opening overlap						
Material S. A. E. 1041, 1047 Steel						
Overall length 5.093						
Actual overall head dia. 1.875						
Angle of seat & face 45°						
Seat insert material None						
Stem diameter .3432 - .3427						
Stem to guide clearance .0010 - .0025						
Intake	Lift (@ zero lash)		.428	.435	.444	
	Outer spring press. and length	Valve closed (lb. @ in.)	90 @ 1.837			
		Valve open (lb. @ in.)	182 @ 1.437			
	Inner spring press. and length	Valve closed (lb. @ in.)	None			
		Valve open (lb. @ in.)	None			
	Material G. M. N82152 Steel					
	Overall length 5.081					
	Actual overall head dia. 1.562					
	Angle of seat & face 45°					
Seat insert material None						
Stem diameter .3427 - .3422						
Stem to guide clearance .0015 - .0030						
Exhaust	Lift (@ zero lash)		.435			
	Outer spring press. and length	Valve closed (lb. @ in.)	90# @ 1.837			
		Valve open (lb. @ in.)	182# @ 1.437			
	Inner spring press. and length	Valve closed (lb. @ in.)	None			
		Valve open (lb. @ in.)	None			

ENGINE--LUBRICATION SYSTEM

Type of lubrication (splash, pressure, nozzle)	Main bearings	Pressure
	Connecting rods	Pressure
	Piston pins	Splash
	Camshaft bearings	Pressure
	Tappets	Pressure
	Timing gear or chain	Pressure
	Cylinder walls	Pressure

(Continued)

AMA Specifications – Passenger Car

MAKE OF CAR Oldsmobile MODEL YEAR 1963 DATE ISSUED 9-1-62 REVISED (*)

MODEL 3200 3500 & 3800 3600 & 3900

ENGINE—LUBRICATION SYSTEM (cont.)

Oil pump type	Gear	
Normal oil pressure (lb. @ engine rpm)	35-45 @ 50 M. P. H.	
Oil pressure sending unit (elect. or mech.)	Electric	
Type oil intake (floating, stationary)	Stationary	
Oil filter system (full flow, partial, other)	Full Flow	
Filter replacement (element, complete)	Complete	
Capacity of crankcase, less filter-refill (qt.)	4 Quarts	
Oil grade recommended (SAE viscosity and temperature range)	Above 32° F - S. A. E. 10W-30, SAE 20W Below 32° F & Above 0° F. SAE 5W-20, SAE 10W Below 0° F SAE 5W-20, SAE 5W	
Engine Service Requirement (MM, MS, etc.)	MS	(or Meets G. M. 4745 M)

ENGINE—EXHAUST SYSTEM

Type (single, single with cross-over, dual, other)	Single with Crossover	Single with Crossover	Dual
Muffler No. & type (reverse flow, straight thru, separate resonator)	Reverse Flow	Reverse Flow	Reverse Flow Separate Resonator
Exhaust pipe dia. (O.D. & wall thickness)	Branch	2.00 O. D. X .090	
	Main	2.25 O. D. X .036 & .048 Laminated	
Tail pipe diameter (O.D. & wall thickness)	2.25 O. D. X .054		

ENGINE—CRANKCASE VENTILATION SYSTEM

Type (ventilates to atmos., induction system, other)	Standard	Positive Crankcase Ventilation
	Optional	None
Control unit	Make and model	A. C. Dual Action
	Location	Valve Cover
	Energy source (manifold vacuum, carburetor air stream, other)	Manifold Vacuum and Carburetor Air
Complete system	Control method (variable orifice, fixed orifice, other)	Fixed Orifice
	Discharges (to Intake manifold, carb. air Intake, air cleaner Intake, other)	Intake Manifold and Air Cleaner
	Air inlet (breather cap, carburetor air cleaner, other)	Breather Cap
	Flame arrestor (screen, check valve, other)	Screen

AMA Specifications— Passenger Car

MAKE OF CAR Oldsmobile MODEL YEAR 1963 DATE ISSUED 9-1-62 REVISED (*)

MODEL 3200 3500 & 3800 3600 & 3900

ENGINE—FUEL SYSTEM

(See Supplement to Page 8 for Details of Fuel Injection, Supercharger, etc. if used)

Induction type: Carburetor, fuel injection, supercharger.		Carburetor			
Fuel Tank	Capacity (gals.)	21 Gallons			
	Filler location	L. H. Rear Quarter			
Fuel Pump	Type (elec. or mech.)	Mechanical			
	Locations				
	Pressure range	5 lbs. to 6 lbs. @ 16" Above Outlet @ 1800 Camshaft R. P. M.			
Vacuum booster (std., optional, none)		Standard			
Fuel Filter	Type	Accreted & Saran Type			
	Locations	Fuel Pump and Fuel Tank			
Carburetor	Choke type	Automatic			
	Intake manifold heat control (exhaust or water)	Exhaust			
	Air clnr. type	Standard	Polyurethane	Paper	Paper
		Optional	Paper	None	None

CARBURETOR SUPPLEMENTARY INFORMATION

Model Usage	Engine Displ.	Transmission	Carburetors		No. Used and Type	Barrel Size
			Make	Model		
3200 (Std.)	394		Rochester	2 GC	Single Dual	1.6875
32 (Opt.)	394		Rochester	4 GC	Single Quad.	1.5625 Prim 1.6875 Sec.
3500 & (Std.) 3800	394		Rochester	4 GC	Single Quad.	1.5625 Prim 1.6875 Sec.
3600 & (Std.) 3900	394		Rochester	4GC	Single Quad.	1.5625 Prim. 1.6875 Sec.

AMA Specifications – Passenger Car

MAKE OF CAR Oldsmobile MODEL YEAR 1963 DATE ISSUED 9-1-62 REVISED(*)

MODEL _____ 32 _____ 35 _____ 38

ENGINE—COOLING SYSTEM

Type system (pressure, pressure vented, atmospheric, other)		Pressure System		
Radiator cap relief valve pressure		15 Pounds		
Circulation thermostat	Type (choke, bypass)	Choke		
	Starts to open at (°F)	167° - 172°		
Water pump	Type (centrifugal, other)	Centrifugal		
	GPM @ 1000 pump rpm	17.5		
	Number of pumps	One		
	Drive (V-belt, other)	V-Belt		
Bearing type		Ball		
By-pass recirculation type (internal, external)		Internal		
Radiator core type (cellular, tube and fin, other)		Tube & Center		
Cooling system capacity	With heater (qt.)	20.25		
	Without heater (qt.)	19.25		
	Opt. equipment-specify (qt.)	1.65 Additional for Air Conditioned Cars		
Water jackets full length of cylinder (yes, no)		Yes		
Water all around cylinder (yes, no)		Yes		
Radiator hose	Lower	Number and type (molded, straight)	SAE 20 R 4 Class R - Grade 1A One - Molded - Modified	
		Inside diameter	1.75	
	Upper	Number and type (molded, straight)	SAE 20 R 4 Class R - Grade 1A One - Molded - Modified	
		Inside diameter	1.50	
	By-pass	Number and type (molded, straight)	None	
		Inside diameter	None	
	Fan	Number of blades & Spacing		4 - 76° & 104° (6 A/C)
		Diameter		18" (19" A/C)
Ratio-fan to crankshaft rev.		.817 to 1 (1.33 to 1 A/C)		
Fan cutout type		None (Fan Clutch - A/C)		
Bearing type		Ball		
*Drive belts (indicate belt used by letter)	Fan		A	
	Generator		B	
	Water Pump		C	
	Power Steering		D	
	Air Conditioning		E	

* Drive Belt Dimensions	A	B	C	D	E
Angle of V	36°	36°	36°	36°	36°
Nominal length (SAE)	52.41	52.41	52.41	52.41	67.00
Width	.380	.380	.380	.380	.380

AMA Specifications – Passenger Car

MAKE OF CAR Oldsmobile MODEL YEAR 1963 DATE ISSUED 9-1-62 REVISED (e)

MODEL 3200 3500 & 3800 3600 & 3900

ELECTRICAL—SUPPLY SYSTEM

Battery	Make and Model	Delco Remy 562		
	Voltage Rtg. & Total Plates	12-V-11 Plates		
	SAE Designation & Amp Hr. Rtg.	3 KMB - 70 Amp HR		
	Location	Engine Compartment, Front L. H. Side		
	Terminal grounded	Negative		
Generator	Make	Delco Remy		
	Model	1100624	1100616	
	Type	Self Rectifying AC		
	Ratio—Gen. to Cr/s rev.	2.34	2.83	
	Gen. cut-in (hot)—engine rpm	Charge on Idle		
Regulator	Make	Delco Remy		
	Model	1119507		
	Type	Vibrating Contact		
	Cutout relay	Closing voltage @ generator rpm	None	
		Reverse current to open	None	
	Regu-lated	Voltage	13.5 - 14.4	
		Current	None - Self Regulating	
	Voltage test con-ditions	Temperature	125° F	
		Load	Less than 10 Amps	
Other		Upper Contacts		

ELECTRICAL—STARTING SYSTEM

Starting motor	Make	Delco Remy		
	Model			
	Rotation (drive end view)	Clockwise		
	Engine cranking speed	150		
	Test conditions	80° F		
	Lock test	Amps	Not Specified	
		Volts	"	"
		Torque (lb. ft.)	"	"
	No load test	Amps	80 to 120	
Volts		10.6		
RPM (min.)		3900		
Motor control	Switch (solenoid, manual)	Solenoid		
	Starting procedure	Turn Ignition Key Against Spring Load, to Full Clockwise Position. Cars with Hydra-Matic Must Be on Park or Neutral to Start.		

(Continued)

AMA Specifications – Passenger Car

MAKE OF CAR Oldsmobile **MODEL YEAR** 1963 **DATE ISSUED** 9-1-62 **REVISED** ^(a)

MODEL 3200 3500 & 3800 3600 & 3900

ELECTRICAL—STARTING SYSTEM (cont.)

Motor Drive	Engagement type	Solenoid with Overrunning Clutch		
	Pinion meshes (front, rear)	Front		
	Number of teeth	Pinion	9	
		Flywheel	166	
	Flywheel tooth face width	NA		

ELECTRICAL—IGNITION SYSTEM

Coil	Make	Delco Remy		
	Model	1115112		
	Amps	Engine stopped	4.5	
Engine idling		2.0		
Distributor	Make	Delco Remy		
	Model	1111033		
	Cent'fgal adv. in crankshaft degrees @ engine rpm (nominal)	Start (rpm)	0° - 4° @ 800 R. P. M.	
		Intermediate points deg. @ rpm	18° - 22° @ 2400 R. P. M.	
		Max deg. @ rpm	24° - 28° @ 4000 R. P. M.	
	Vacuum adv. in crankshaft degrees @ in. Hg. (nominal)	Start (in Hg)	9 - 11	
		Intermediate points, deg @ in Hg	N. A.	
		Max. deg. in. Hg.	25° @ 19 in. HG	
		Breaker gap (in.)	.016	
		Cam angle (deg.)	28 to 32	
	Breaker arm tension (oz.)	19 to 23		
Timing	Crankshaft deg. @ rpm.	5° @ 850 R. P. M. except 3200 S. M. T. : 2.5° @ 850 R. P. M.		
	Mark location	Vibration Dampener		
	Cylinder numbering system (see page 2)	Right Bank 2 -4 -6 - 8	Left Bank 1 - 3 - 5 - 7	
	Firing order (see page 2)	1 - 8 - 7 - 3 - 6 - 5 - 4 - 2		
Spark Plug	Make and model	AC 44		
	Thread (mm)	14 MM		
	Tightening torque (lb. ft.)	23 - 28		
	Gap	.030		
Cable	Conductor type	Resistance		
	Insulation type	Neoprene		
	Spark plug protector	Silicone		

ELECTRICAL—SUPPRESSION

Locations & type	Resistance Core Sparkplug Leads & Coil Lead. Bypass Condensers at Alternator, Regulator, & Coil on Radio, Equipped Cars.
-----------------------------	--

AMA Specifications – Passenger Car

MAKE OF CAR Olds B & C MODEL YEAR 1963 DATE ISSUED 9-1-62 REVISED (e)

MODEL 32 35 38

ELECTRICAL—INSTRUMENTS AND SWITCHES

Speed-ometer	Make			AC
	Trip odometer (yes, no)			No
Charge indicator—type				Ind. Lamp
Temperature indicator—type				" "
Oil pressure indicator—type				" "
Fuel indicator—type				Gauge
Other	Hi Beam			Ind Lamp
	Tachometer		36 and 39 Models	In Console
Ignition switch	Identify positions in order and circuits controlled	1	Accessory On, Ign Off	
		2	All Off - Lock Position	
	Run -	3	Accessory on, Ign through Resistor	
	Start -	4	Accessory Off Ign Direct Solenoid On	
	Provision for illumination			Yes
	Location		Instrument Panel Right of Driver	
Main lighting switch	Identify positions and lamps controlled	1	Part, Instrument, Tail and License Lts.	
	Rotate Control	2	Headlamps, Instrument, Tail and License Lt. Dims Instrument Lts.	
Other light switches	Locations and lamps controlled	1	On L. H. Toe Pan Controls Headlamps Hi and Lo Beam	
	Foot Dimmer Map Lt. Courtesy Lt.		R. H. Side of Instrument Panel Overhang Controls Courtesy Lts. and Map Lt.	
Other switches	Locations and devices controlled		Left of Driver on Instrument Panel	
	W/S Wiper		Right of Driver on Instrument Panel	
	Heater		Center of Instrument Panel in Overhang -	
	Power Top Elec. Ant		Center of Instrument Panel in Overhang -	
Windshield wiper	Make		Delco Appliance Div.	Delco Appliance Div.
	Type		Elec. Single Speed	Elec. Two Speed
	Vacuum booster provision			No
	Washer provision			Yes
Horn	Type		Vibrator	
	Number used		2	
	Amp draw (each)		8 - 10 Amps - 115 Volts	

AMA Specifications – Passenger Car

MAKE OF CAR	Olds	B & C	MODEL YEAR 1963	DATE ISSUED 9-1-62	REVISED (e)
MODEL	32	35	36	38	39

ELECTRICAL—LAMP BULBS

Give quantity used and trade number, e.g., Headlamp 2-5400 S, dual headlight 2-4001, 2-4002.
 Indicate accessories which are not standard equipment by an asterisk following the numbers.

		Dual Headlights 2-5948502		2-5948501	
Headlamps & arrangement					
Headlamp beam indicator		1 - 158			
Parking		2 - 1034			
Tail		2 - 1034			
Stop		2 - 1034			
Direction signal	Front	2 - 1034			
	Rear	2 - 1034			
	Indicator	2 - 158			
License plate		1 - 67			
Instrument		3 - 158			
Ignition lock		1 - 53			
Back up		2 - 1073			
Dome		1 - 1004	2 - 90	2 - 90	2 - 90
Clock		1 - 1816			
Radio		1 - 1893			
Glove compartment		1 - 57			
Temp Ind		Hot 1 - 158			
Temp Ind.		Cold 1 - 158			
Oil "P" Ind.		1 - 158			
Gen Warn		1 - 158			
Safe Sent		1 - 158			
Shift Ind.		1 - 57	1 - 57	2 - 53	1 - 57 2 - 53
Heat & Vent		1 - 57			
Tachometer		1 - 57			
Ash Tray		1 - 53			
Cruise Cont		1 - 53			
Brake Warn		1 - 57X			
Under Hood		1 - 89			
Trunk		1 - 89			
Courtesy		2 - 90			
R. R Courtesy		2 - 90			
Map Lt.		1 - 90			
		2 - 90			

AMA Specifications – Passenger Car

MAKE OF CAR Olds B & C MODEL YEAR '63 DATE ISSUED 9-1-62 REVISED (e)

MODEL 32 35 36 - 38 - 39

ELECTRICAL—FUSE & CIRCUIT BREAKER DATA

Use trade number of fuse, e.g., SFE-10. Indicate circuit breaker by ampere capacity suffixed by letters "C.B.", e.g., 30 C.B. Where fuse or circuit breaker protects multiple circuits indicate first use by a letter and repeat the same letter for all units protected by the same fuse or circuit breaker, e.g., Parking lamp SFE-10 (a), Direction indicator same as (a).

Headlamp	20 CB (A)	
Headlamp beam indicator	Same as (A)	
Parking lamp	Same as (A)	
Tail lamp	SFE 9 (B)	
Stop lamp	SFE 20 (C)	
Direction indicator	SFE 9 (D)	
License plate lamp	Same as (B)	
Instrument lamp	AGA 3 (E)	
Ignition lamp	Same as (E)	
Back up lamp	SFE 9 (F)	
Dome lamp	SFE 20 (G)	AGC - 25 (G)
Clock	AGA 2	
Clock lamp	Same as (E)	
Radio	AG N2 1/2	AGN-7 1/2 Super Dlx.
Glove compartment lamp	AGC 5 (F)	
Under Hood Lt.	Same as (F)	
W/S Wiper	SFE 20	
Cigar Ltr.	SFE 20	
Ind Lts.	Same as (F)	
Fuel Gauge	Same as (F)	
Brake Warn	Same as (F)	
Trunk Lt.	Same as (B)	
Courtesy Lt.	Same as (G)	
Heat Cont. Lt.	Same as (E)	
Heater	SFE 20	AGC 25 with A/C

Tach Feed

ELECTRICAL—LOCATION OF OUTSIDE LAMPS

		32	35	36	38	
Height above ground to center of bulb	Tail					
		Highest	25.61 (27.53 s.w.)*	25.53	29.97	
		Stop	25.61 (27.53 s.w.)*	25.53	29.97	
		Backup	14.53 (16.45 s.w.)*	14.53	22.95	
		License, rear	19.17	19.17	19.02	
		Directional	Front	16.33 (16.00 s.w.)*	16.33	16.57
			Rear	25.61 (27.53 s.w.)*	25.53	29.97
		Headlamp	Inside	26.35	26.35	26.59
			Outside*	26.03	26.03	26.27
	Distance from C/L of car to center of bulb	Tail				
		Outside	33.55			
		Stop	33.55			
		Backup	14.60	14.60	23.85	
		License, rear	On Center			
		Directional	Front	27.05		
			Rear	33.55		
		Headlamp	Inside	23.56		
	Outside*		30.54			

* If single headlamps are used enter here.

* SW - Fiesta Models

AMA Specifications – Passenger Car

MAKE OF CAR Oldsmobile MODEL YEAR 1963 DATE ISSUED 9-1-62 REVISED (*)

MODEL 32 - 35 36 - 38 - 39

DRIVE UNITS—CLUTCH (Manual Transmission)

Make & type	Long - 11 CF - Semi-centrifugal	N. A.
Type pressure plate springs	Coil	
Effective plate pressure (lb.)	2043 Static +505 at 2800 RPM Centrifugal	N. A.
No. of clutch driven discs	One	N. A.
Clutch facing	Material	Woven Asbestos
	Outside & inside dia.	11 x 7
	Total eff. area (sq.in.)	113
	Thickness	.137 Each Facing
	Engagement cushioning method	Torbend Plate
Release bearing	Type & method of lubrication	Ball - Lube Fitting
Torsional damping	Methods: springs, friction material	Coil Springs - Steel Friction

DRIVE UNITS—TRANSMISSIONS

Manual (std. or opt.)	Standard	None
Manual with overdrive (std. or opt.)	None	None
Automatic (std. or opt.)	Optional	Standard

DRIVE UNITS—MANUAL TRANSMISSION

Number of forward speeds	3	N. A.	
Transmission ratios	In first	2.1527:1	
	In second	1.3725:1	
	In third	Direct	
	In fourth	---	
	In reverse	2.2793:1	
Synchronous meshing, specify gears	2 & 3		
Shift lever location	St. Col.		
Lubricant	Capacity (pt.)	2.5	
	Type recommended	Multipurpose	
	SAE viscosity number	Summer	80 or 90
		Winter	80 or 90
Extreme cold		80 or 90	

AMA Specifications – Passenger Car

MAKE OF CAR Oldsmobile MODEL YEAR 1963 DATE ISSUED 9-1-62 REVISED (*)

MODEL _____ 32 35 36 38 39

DRIVE UNITS—MANUAL TRANSMISSION WITH OVERDRIVE

For transmission data see manual transmission section

Overdrive	Type (planetary or other)		X
	Manual lockout (yes, no)		
	Downshift accelerator control (yes, no)		
	Minimum cut-in speed		
	Gear ratio		
	Capacity (pt.) (Overdrive only)		
Lu- bri- cant	Separate filler (yes, no)		
	Type recommended		
	SAE vis- cosity number	Summer	
		Winter	
Ext. cold			

DRIVE UNITS—AUTOMATIC TRANSMISSION

Trade name	Hydra-matic															
Type describe	4 Stage, Controlled Coupling with Accel-A-Rotor															
Method of Selection (Lever, Push Button or other)	Lever															
Selector Pattern	<table style="display: inline-table; border: none;"> <tr> <td style="text-align: center;">P</td> <td style="text-align: center;">N</td> <td style="text-align: center;">D</td> <td style="text-align: center;">S</td> <td style="text-align: center;">L</td> <td style="text-align: center;">R</td> </tr> <tr> <td style="text-align: center;">Park</td> <td style="text-align: center;">Neutral</td> <td style="text-align: center;">Drive</td> <td style="text-align: center;">Super</td> <td style="text-align: center;">Low</td> <td style="text-align: center;">Reverse</td> </tr> </table>	P	N	D	S	L	R	Park	Neutral	Drive	Super	Low	Reverse			
P	N	D	S	L	R											
Park	Neutral	Drive	Super	Low	Reverse											
List gear ratios Selector Pattern and indicate which are used in each selector position	<table style="display: inline-table; border: none;"> <tr> <td style="text-align: center;">Drive & Super</td> <td style="text-align: center;">Low</td> <td style="text-align: center;">Reverse</td> </tr> <tr> <td>1st Stage = 3.32:1</td> <td>3.32:1</td> <td>3.11:1</td> </tr> <tr> <td>2nd Stage = 2.93:1</td> <td>2.93:1</td> <td>2.43:1</td> </tr> <tr> <td>3rd Stage = 1.56:1</td> <td>Not Used</td> <td></td> </tr> <tr> <td>4th Stage = Direct</td> <td>Not Used</td> <td></td> </tr> </table>	Drive & Super	Low	Reverse	1st Stage = 3.32:1	3.32:1	3.11:1	2nd Stage = 2.93:1	2.93:1	2.43:1	3rd Stage = 1.56:1	Not Used		4th Stage = Direct	Not Used	
Drive & Super	Low	Reverse														
1st Stage = 3.32:1	3.32:1	3.11:1														
2nd Stage = 2.93:1	2.93:1	2.43:1														
3rd Stage = 1.56:1	Not Used															
4th Stage = Direct	Not Used															
Max. upshift speeds—drive range	1-2 * 2 - 3 = 35 MPH 3 - 4 = 78 MPH															
Max. kickdown speeds—drive range	2-1 * 3 - 2 = 24 MPH 4 - 3 = 68 MPH															
Torque converter	Number of elements	None														
	Max. ratio at stall	None														
	Type of cooling (air, water)	Water														
Lubricant	Capacity—refill (pt.)	11 Pints														
	Type recommended	Type - A - Automatic Transmission Fluid with Suffix A.														
Special transmission features	* Accel-A-Rotor and Rear Unit Gears Produce Starting Ratio for 1st Stage. As the Car Speed Increases Accel-A-Rotor Effectiveness Diminishes Gradually.															

DRIVE UNITS—PROPELLER SHAFT

Number used	One	
Type (exposed, torque tube)	Exposed	
Outer diameter x length* x wall thickness	Manual transmission	3.38 x 58.00 x .065 None
	Overdrive transmission	None
	Automatic transmission	3.00 x 58.00 x .065 3.25 x 61.00 x .065

*Center to center of universal joints, or to centerline of rear attachment.

AMA Specifications – Passenger Car

MAKE OF CAR Oldsmobile MODEL YEAR 1963 DATE ISSUED 9-1-62 REVISED (a)

MODEL 32 35 36 38 39

DRIVE UNITS—PROPELLER SHAFT (cont.)

Intermediate bearing	Type (plain, anti-friction)	Anti - friction				
	Lubrication (fitting, prepack)	Prepack				
Universal joints	Make	Saginaw Steering Gear & Spicer				
	Number used	Two				
	Type (ball and trunnion, cross, other)	Cross				
	Bearing	Type (plain, anti-friction)	Anti - friction			
Lubric. (fitting, prepack)		Prepack				
Drive taken through (torque tube or arms, springs)		Arms				
Torque taken through (torque tube or arms, springs)		Arms				

DRIVE UNITS—REAR AXLE

Description (see Instructions)		Banjo - Live - Hypoid - Semi-floating					
Limited Slip differential, type		Multiple Plate Clutch					
Drive Pinion Offset		1.75					
No. of differential pinions							
Gear ratios (Std. equip.)	Manual transmission	3.23:1	3.23:1	N. A.	N. A.	N. A.	
	Overdrive transmission	None					
	Automatic transmission	2.56:1	2.87:1	3.42:1	3.08:1	3.42:1	
Ring gear O.D. (std. ratio)		9.25					
Pinion adjustment (shim, other)		Shim					
Pinion bearing adj. (shim, other)		Coll. Spacer					
Wheel bearing type		Ball					
Lubricant	Capacity (pt.)	5.58					
	Type recommended	Multi-purpose					
	SAE viscosity number	Summer	90				
		Winter	90				
Extreme cold		90					

REAR AXLE RATIO TOOTH COMBINATIONS

(See page 3 for axle ratio usage)

Axle ratio		2.56:1	2.69:1	2.87:1	3.08:1	3.23:1	3.42:1
No. of teeth	Pinion	16	16	15	13	13	12
	Ring gear	41	43	43	43	42	41

AMA Specifications – Passenger Car

MAKE OF CAR Oldsmobile MODEL YEAR 1963 DATE ISSUED 9-1-62 REVISED (6)

MODEL 32 35 38

DRIVE UNITS—WHEELS

Type & material		Drop Center - Welded Wheels	
Rim (size and flange type)	Std.	14 x 6K	
	Opt.	14 x 6K	
Attachment	Type (bolt or stud)	Stud	
	Circle diameter	5.00	
	Number and size	5 x 1/2	

DRIVE UNITS—TIRES

Standard (List option below)	Size & ply	8.00 x 14	8.00 x 14 Ply	8.50 x 14
	Type - Nylon, etc.	Rayon		
Rev/mile at 50 mph.		755	755	735
Inflation press.(cold)	Front	22	22	22
	Rear	22	22	22
Optional tires - size and ply				

BRAKES—SERVICE

Type (duo-servo, disc, balanced, etc.)		Duo - Servo	
Self adjusting (std., opt., N.A.)		Standard	
Hydraulic system type (single, dual, etc.)		Single	
Power brake make & type (remote, integral, etc.)		Moraine & Bendix (Integral)	
Effective area (sq. in.)*		156.8	
Gross lining area (sq. in.)**		191.7	
Swept drum area (sq. in.)***		310.0	
Percent brake effectiveness—front		56%	
Drum	Diameter	Front	11.0
		Rear	11.0
Type and material		Centrifuse Cast Iron in Steel Shell	
Wheel cylinder bore	Front	1 1/8	
	Rear	1"	
Master cylinder bore		1" Manual	1" Power
Available pedal travel		5.50 Manual	3.82 Power
Line pressure at 100 lb. pedal load		750 PSI Manual	700 @ 50 lb. Pedal Load
Shoe clearance adjustment		.015	

* Excludes rivet holes, grooves, chamfers, etc.

** Includes rivet holes, grooves, chamfers, etc.

*** Total swept areas for four brakes:
 Widest lining contact width for each brake x its drum circumference.

(Continued)

AMA Specifications—Passenger Car

MAKE OF CAR Oldsmobile MODEL YEAR 1963 DATE ISSUED 9-1-62 REVISED(*)

MODEL 32 35 38

BRAKES—SERVICE (cont.)

		Bonded or riveted		Riveted	
Brake lining	Front Shoe	Material		Marshall 4641 Pri.	
		Size (length x width x thickness)	Front wheel	12 x 2.50 x .25	
			Rear wheel	12 x 2.00 x .25	
		Segments per shoe		One	
	Rear Shoe	Material		Marshall 9795 D	
		Size (length x width x thickness)	Front wheel	9 x 2.50 x .25	
			Rear wheel	9 x 2.00 x .25	
		Segments per shoe		One	

BRAKES—PARKING

Type of control		Suspended Pedal
Location of control		Left Driver's Compartment
Operates on		Rear Brakes
If separate from service brakes	Type (internal or external)	Not Separate
	Drum diameter	"
	Lining size (length x width x thickness)	"

FRAME or UNITIZED CONSTRUCTION

Type and description	Box Section Side Rails and 4 Cross Bars (Guard-Beam Frame)
----------------------	---

SUSPENSION—GENERAL (See Supplemental page 19 for details on Air Suspension)*

Provision for car leveling		None
Provision for brake dip control		Counter Dive Design of Suspension
Provision for acc. squat control		Springs and Control Arms
Special provisions for car jacking		None
Shock absorber front & rear	Type	Direct Acting
	Make	Delco
	Piston dia.	1 Inch
Other special features		None

SUSPENSION—FRONT

Type and description	Independent Coil Spring
----------------------	-------------------------

* Air Suspension: Normal operating pressures
 Air spring type spring rates
 Compressor data leveling data
 type
 make
 drive ratio

(Continued)

AMA Specifications – Passenger Cars

MAKE OF CAR Oldsmobile MODEL YEAR 1963 DATE ISSUED 9-1-62 REVISED (*)

MODEL 32 35 38

SUSPENSION FRONT (cont.)

Spring	Type	Independent Coil Spring		
	Material	SAE 9260		
	Size (coil design height & I.D.; bar length x dia.)	11" Design Height - 4.05 I. D. 155" Long .690 Dia.	11" Design Height-4.05 I. D. 162" Long .700 Dia.	
	Spring rate (lb. per in.)	335	335	335
	Rate at wheel (lb. per in.)	97.3		
Stabilizer	Design load (lb. @ design height)	2430 @ 11"	2430 @ 11"	2570 @ 11"
	Type (link, linkless, frameless)	Link		
	Material & bar diameter	SAE 1070 - 1.093	1.093	1.125

STEERING

Mechanical (std., opt., NA)		Standard			
Power (std., opt., NA)		Optional			
Wheel diameter		16.00	16.00	16.00	
Turning diameter	Outside front	Wall to wall (l. & r.)	45.3	47.5	
		Curb to curb (l. & r.)	42.8	44.1	
	Inside rear	Wall to wall (l. & r.)	26.7	28.4	
		Curb to curb (l. & r.)	27.4	29.1	
Outside wheel angle with inside wheel at 20°		Manual 18.1° Power 17.6°			
Mechanical	Gear	Type	Ball Nut		
		Make	Saginaw Steering Gear	N. A.	
		Ratios	Gear	24.0:1	"
			Overall	33.24:1	"
	No. wheel turns	6.1 (Lock to Lock)			
Power	Type (coaxial, linkage, etc.)	Gear Integral			
	Make	Saginaw Steering Gear			
	Trade name	Roto-Matic			
	Gear	Type	Ball Nut		
		Ratios	Gear	17.5:1	
			Overall	21.77:1	
	Pump driven by	Belt from Crank			
	Number wheel turns	3.8 (Lock to Lock)			
Linkage	Type	Forged			
	Location (front or rear of wheels, other)	Rear			
	Drag link (trans. or longit.)	Transverse			
	Tie rods (one or two)	2			

(Continued)

AMA Specifications – Passenger Car

MAKE OF CAR Oldsmobile MODEL YEAR 1963 DATE ISSUED 9-1-62 REVISED (•)

MODEL 32 35 38

STEERING (cont)

Steering Axis	Inclination at camber (deg.)		10° at + 1° Camber
	Bearings (type)	Upper	Ball Joint
		Lower	"
	Thrust		"
Wheel alignment (range and preferred)	Caster (deg.)		Range 0 to 1° Negative
	Camber (deg.)		Range - 1/4° to + 3/4°
	Toe-in (outside tread-inches)		0 to .12
Steering spindle & joint type			Ball Joint
Wheel spindle	Diameter	Inner bearing	1.3748 - 1.3743
		Outer bearing	.8435 - .8430
	Thread size		13/16 - 20
	Bearing type		Tapered Roller

SUSPENSION—REAR

Type and description			4 Link Coil Spring			
Drive and torq. taken through (see page 17)			Arms			
Spring	Type		Coil			
	Material		SAE # 5160 or 9260			
	Size (length x width, coil design height and I.D.; bar length & dia.)		9.00 Design Height - 5.50 I. D. 137" Long .568 Dia.	9.00 Design Height-5.50 I. D. 148" Long .580 Dia.		
	Spring rate (lb. per in.)		100			
	Rate at wheel (lb. per in.)		105.6			
	Design load (lb. at design height)		1040 @ 9"	1040 @ 9"	1100 @ 9"	
	Mounting insulation type			Rubber		
	If leaf	No. of leaves		-		
		Inserts	Type and size		-	
			Material		-	
Shackle (comp. or tens.)		-				
Stabilizer	Type (link, linkless, frameless)		None			
	Material		None			
Track bar type			None			

MAKE OF CAR Oldsmobile MODEL YEAR 1963 DATE ISSUED 9-1-62 REVISED (a)

CAR AND BODY DIMENSIONS—GENERAL

NOTE: Included in the dimension definitions listed on pages 34-36 are those which have been adopted by SAE. These are indicated by a number following the type of dimension, e.g., L3. Additional dimensions have been added by the AMA Specifications Review Committee. These are shown by an additional letter, e.g., H67a. The symbol "a" has been added as a suffix to denote a dimension adopted by the AMA and submitted to the SAE for approval. The dimensions are developed from the following basic points:

1. Body dimensions are for all body styles.
2. All interior dimensions are taken with manikin 15.0 inches outboard of car centerline unless otherwise stated.
3. All interior dimensions are measured with the front seat in the lowest and rearmost position.
4. Unless otherwise specified, all exterior height dimensions are taken with a full design load which consists of 5 passengers, 300 lbs. front, 450 lbs. rear; includes spare wheel, tire and tools, and full complement of gas, oil, water and tires to recommended pressure, etc.
5. The SAE manikin with 90th percentile leg length will be used for recording purposes.
6. The H Point is the pivot center of the manikin's torso and thigh.
7. The Torso Line is a line parallel to the small of manikin's back and extending through the H Point.

EXTERIOR WIDTH DIMENSIONS

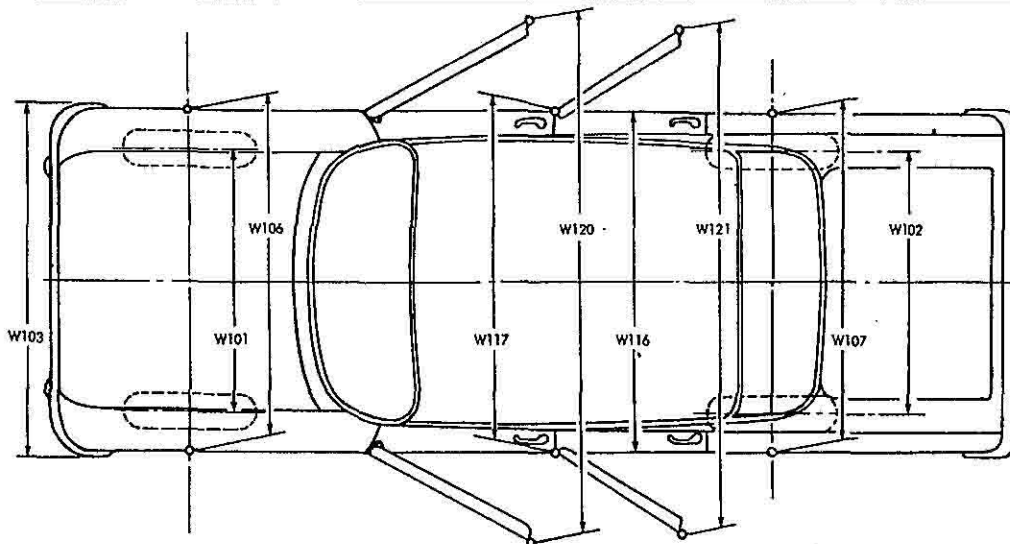

MODEL	Ref. No.	3239	3247	3267	3269	3235-45	3539	3547	3569	3535
Tread - front	W101	62.2	62.2	62.2	62.2	62.2	62.2	62.2	62.2	62.2
Tread - rear	W102	61.0	61.0	61.0	61.0	61.0	61.0	61.0	61.0	61.0
Maximum overall car width	W103	77.9	77.9	77.9	77.9	77.9	77.9	77.9	77.9	77.9
Maximum overall body width	W116	77.5	77.5	77.5	77.5	77.5	77.5	77.5	77.5	77.5
Maximum body width at #2 pillar	W117	75.4	-	-	75.4	75.4	75.4	-	75.4	75.4
Front fender overall width	W106	77.7	77.7	77.7	77.7	77.7	77.7	77.7	77.7	77.7
Rear fender overall width	W107	77.9	77.9	77.9	77.9	77.5	77.9	77.9	77.9	77.5
Maximum overall car width - front doors open	W120a	141.8	155.9	141.8	141.8	141.8	141.7	155.9	141.7	141.8
Maximum overall car width - rear doors open	W121a	139.3	-	-	139.3	139.3	139.3	-	139.3	139.3

MAKE OF CAR Oldsmobile MODEL YEAR 1963 DATE ISSUED 9-1-62 REVISED (*)

CAR AND BODY DIMENSIONS—GENERAL

NOTE: Included in the dimension definitions listed on pages 34-36 are those which have been adopted by SAE. These are indicated by a number following the type of dimension, e.g., L3. Additional dimensions have been added by the AMA Specifications Review Committee. These are shown by an additional letter, e.g., H67a. The symbol "a" has been added as a suffix to denote a dimension adopted by the AMA and submitted to the SAE for approval. The dimensions are developed from the following basic points:

1. Body dimensions are for all body styles.
2. All interior dimensions are taken with manikin 15.0 inches outboard of car centerline unless otherwise stated.
3. All interior dimensions are measured with the front seat in the lowest and rearmost position.
4. Unless otherwise specified, all exterior height dimensions are taken with a full design load which consists of 5 passengers, 300 lbs. front, 450 lbs. rear; includes spare wheel, tire and tools, and full complement of gas, oil, water and tires to recommended pressure, etc.
5. The SAE manikin with 90th percentile leg length will be used for recording purposes.
6. The H Point is the pivot center of the manikin's torso and thigh.
7. The Torso Line is a line parallel to the small of manikin's back and extending through the H Point.

EXTERIOR WIDTH DIMENSIONS

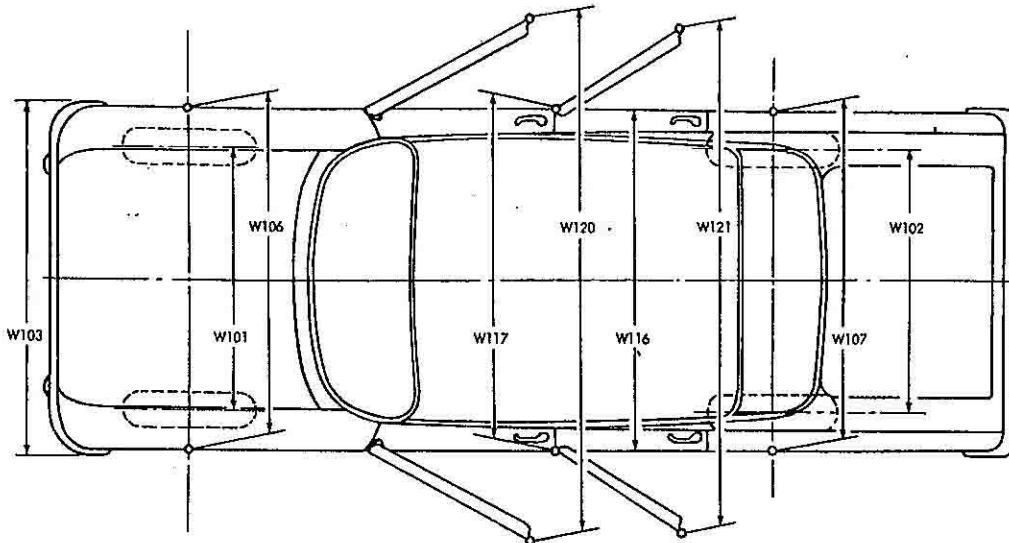

MODEL	Ref. No.	3657	3667	3819	3829	3839	3847	3867	3947
Tread - front	W101	62.2	62.2	62.2	62.2	62.2	62.2	62.2	62.2
Tread - rear	W102	61.0	61.0	61.0	61.0	61.0	61.0	61.0	61.0
Maximum overall car width	W103	77.9	77.9	77.9	77.9	77.9	77.9	77.9	77.9
Maximum overall body width	W116	77.5	77.5	77.5	77.5	77.5	77.5	77.5	77.5
Maximum body width at #2 pillar	W117	-	-	75.4	75.4	75.4	-	-	-
Front fender overall width	W106	77.7	77.7	77.6	77.6	77.6	77.6	77.6	77.6
Rear fender overall width	W107	77.9	77.9	77.8	77.8	77.8	77.8	77.8	77.8
Maximum overall car width - front doors open	W120a	158.1	158.1	141.7	141.7	155.9	155.9	155.9	155.9
Maximum overall car width - rear doors open	W121a	-	-	145.8	145.8	-	-	-	-

AMA Specifications – Passenger Car

MAKE OF CAR Oldsmobile MODEL YEAR 1963 DATE ISSUED 9-1-62 REVISED(*)

EXTERIOR LENGTH DIMENSIONS

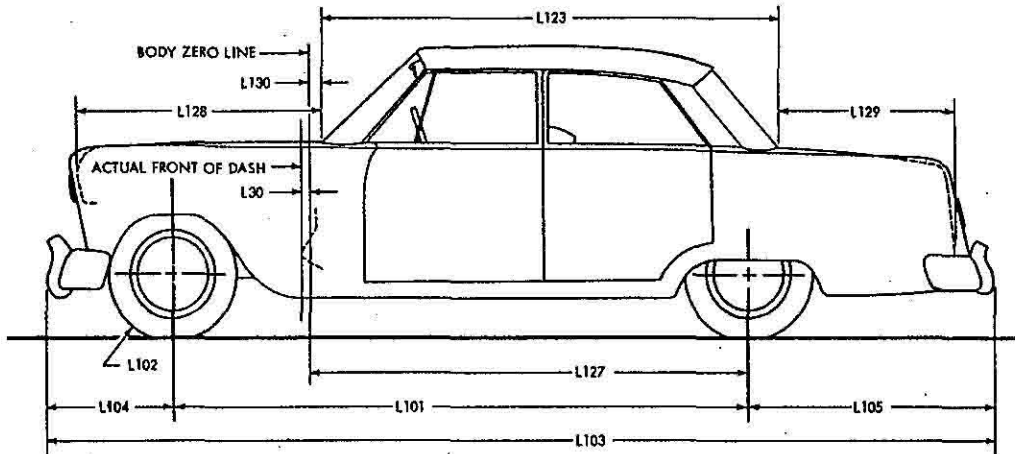

MODEL	Ref. No.	3239	3247	3267	3269	3235-45	3539	3547	3569	3535
Body zero line to actual front of dash	L30	.54	.54	.54	.54	.54	.54	.54	.54	.54
Wheelbase	L101	123.0	123.0	123.0	123.0	123.0	123.0	123.0	123.0	123.0
Overhang - front	L104	34.7	34.7	34.7	34.7	34.7	34.7	34.7	34.7	34.7
Overhang - rear	L105	56.8	56.8	56.8	56.8	56.8	56.8	56.8	56.8	56.8
Overall length	L103	214.5	214.5	214.5	214.5	214.5	214.5	214.5	214.5	214.5
Hood length at car centerline	L128a	54.4	54.4	54.4	54.4	54.4	54.4	54.4	54.4	54.4
Body upper structure length at car centerline	L123	106.2	103.4	105.8	103.6	140.7	106.2	103.4	103.6	140.7
Deck length at car centerline	L129a	46.6	49.3	46.9	49.2	N. A.	46.6	49.3	49.2	N. A.
Body zero line to centerline of rear wheels	L127	101.8	101.8	101.8	101.8	101.8	101.8	101.8	101.8	101.8
Body zero line to windshield cowl point	L130a	3.8	3.9	3.9	3.8	4.4	3.8	3.9	3.8	4.4
Tire size	L102	800 x 14	800 x 14	800 x 14	800 x 14	800 x 14	800 x 14	800 x 14	800 x 14	800 x 14

AMA Specifications – Passenger Car

MAKE OF CAR Oldsmobile MODEL YEAR 1963 DATE ISSUED 9-1-62 REVISED(*)

EXTERIOR LENGTH DIMENSIONS

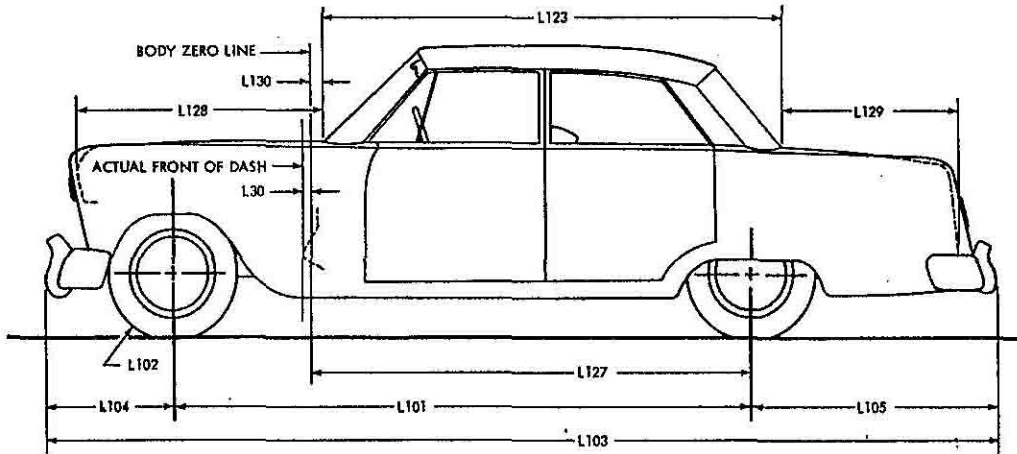

MODEL	Ref. No.	3657	3667	3819	3829	3839	3847	3867	3947
Body zero line to actual front of dash	L30	.54	.54	.54	.54	.54	.54	.54	.54
Wheelbase	L101	123.0	123.0	126.0	126.0	126.0	126.0	126.0	126.0
Overhang - front	L104	34.7	34.7	34.7	34.7	34.7	34.7	34.7	34.7
Overhang - rear	L105	56.8	56.8	61.0	61.0	61.0	61.0	61.0	61.0
Overall length	L103	214.5	214.5	221.7	221.7	221.7	221.7	221.7	221.7
Hood length at car centerline	L128a	54.4	54.4	54.4	54.4	54.4	54.4	54.4	54.4
Body upper structure length at car centerline	L123	103.0	105.8	112.5	112.5	108.8	108.8	108.9	108.8
Deck length at car centerline	L129a	49.9	46.9	46.7	46.7	50.3	50.2	50.2	50.2
Body zero line to centerline of rear wheels	L127	101.8	101.8	104.8	104.8	104.8	104.8	104.8	104.8
Body zero line to windshield cowl point	L130a	3.7	3.9	3.8	3.8	3.9	3.9	3.9	3.9
Tire size	L102	800 x 14	850 x 14	850 x 14	850 x 14	850 x 14	850 x 14	850 x 14	850 x 14

AMA Specifications— Passenger Car

MAKE OF CAR Oldsmobile MODEL YEAR 1963 DATE ISSUED 9-1-62 REVISED (a)

EXTERIOR HEIGHT DIMENSIONS

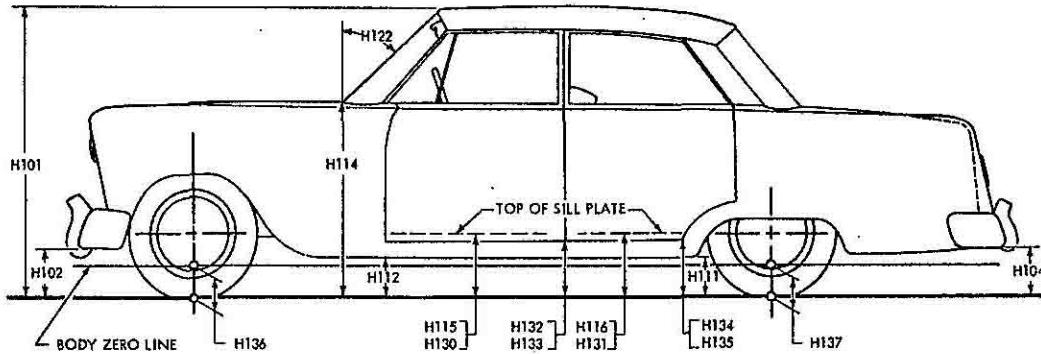

MODEL	Ref. No.	3239	3247	3267	3269	3235-45	3539	3547	3569	3535
Overall height	H101	55.6	55.2	55.9	56.3	58.1	55.6	55.2	56.3	58.1
Hood at rear to ground	H114	38.4	38.4	38.4	38.4	38.6	38.4	38.4	38.4	38.6
Rocker panel to ground - front	H112a	9.1	9.1	9.1	9.1	9.5	9.1	9.1	9.1	9.5
Rocker panel to ground - rear	H111	8.7	8.7	8.7	8.7	9.8	8.7	8.7	8.7	9.8
Step height - front (design load)	H115	13.9	13.8	13.8	13.9	14.2	13.9	13.8	13.9	14.2
Step height - rear (design load)	H116	13.7	-	-	13.7	14.7	13.7	-	13.7	14.7
Step height - front (curb load)	H130	15.8	15.8	15.8	15.8	15.7	15.8	15.8	15.8	15.7
Step height - rear (curb load)	H131	16.0	-	-	16.0	16.2	16.0	-	16.0	16.2
Bottom of door to ground, open - front	H132	13.4	13.5	13.5	13.4	13.9	13.4	13.5	13.4	13.9
Bottom of door to ground, closed - front	H133	12.3	12.2	12.2	12.3	13.0	12.3	12.2	12.3	13.0
Bottom of door to ground, open - rear	H134	12.0	-	-	12.0	13.2	12.0	-	12.0	13.2
Bottom of door to ground, closed - rear	H135	12.0	-	-	12.0	12.9	12.0	-	12.0	12.9
Front bumper to ground	H102	12.0	12.0	12.0	12.0	12.0	12.0	12.0	12.0	12.0
Rear bumper to ground	H104	11.6	11.6	11.6	11.6	11.6	11.6	11.6	11.6	11.6
Windshield slope angle	H122	57.5°	54.5°	54.5°	55°	54.5°	57.5°	54.5°	55°	54.5°
Body zero to ground - front	H136a	5.53	5.53	5.53	5.53	5.53	5.53	5.53	5.53	5.53
Body zero to ground - rear	H137a	5.53	5.53	5.53	5.53	6.78	5.53	5.53	5.53	6.78

AMA Specifications— Passenger Car

MAKE OF CAR Oldsmobile MODEL YEAR 1963 DATE ISSUED 9-1-62 REVISED (*)

EXTERIOR HEIGHT DIMENSIONS

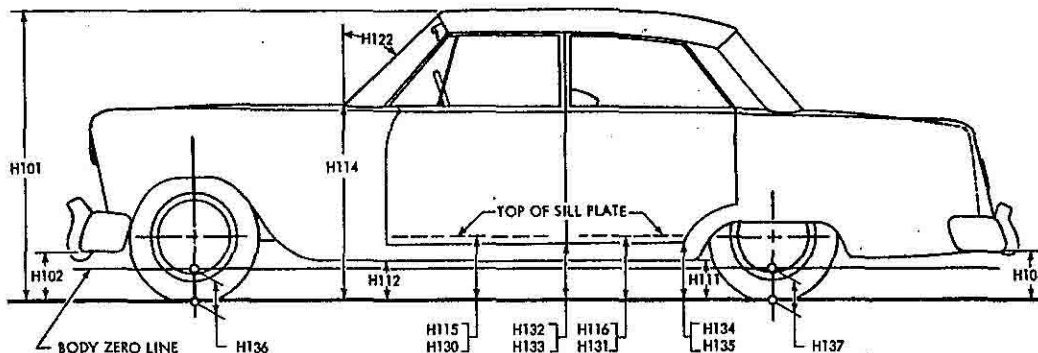

MODEL	Ref. No.	3657	3667	3819	3829	3839	3847	3867	3947
Overall height	H101	55.0	55.9	57.1	57.1	55.1	55.1	55.8	55.1
Hood at rear to ground	H114	38.6	38.6	38.6	38.6	38.6	38.6	38.6	38.6
Rocker panel to ground - front	H112a	9.1	9.4	9.4	9.4	9.4	9.4	9.4	9.4
Rocker panel to ground - rear	H111	8.7	8.9	8.9	8.9	8.9	8.9	8.9	8.9
Step height - front (design load)	H115	13.8	14.1	14.1	14.1	14.1	14.1	14.1	14.1
Step height - rear (design load)	H116	-	-	13.9	13.9	13.9	-	-	-
Step height - front (curb load)	H130	15.8	16.0	16.1	16.1	16.1	16.0	16.0	16.0
Step height - rear (curb load)	H131	-	-	16.2	16.2	16.2	-	-	-
Bottom of door to ground, open - front	H132	13.5	13.5	13.1	13.1	13.1	13.8	13.8	13.8
Bottom of door to ground, closed - front	H133	12.2	12.2	12.0	12.0	12.0	12.4	12.4	12.4
Bottom of door to ground, open - rear	H134	-	-	11.7	11.8	11.8	-	-	-
Bottom of door to ground, closed - rear	H135	-	-	11.8	11.8	11.8	-	-	-
Front bumper to ground	H102	12.0	12.0	12.2	12.2	12.2	12.2	12.2	12.2
Rear bumper to ground	H104	11.6	11.6	11.6	11.6	11.6	11.6	11.6	11.6
Windshield slope angle	H122	57.5°	54.5°	56°	56°	55°	55°	54.5°	55°
Body zero to ground - front	H136a	5.53	5.53	5.77	5.77	5.77	5.77	5.77	5.77
Body zero to ground - rear	H137a	5.53	5.53	5.77	5.77	5.77	5.77	5.77	5.77

AMA Specifications—Passenger Car

MAKE OF CAR Oldsmobile MODEL YEAR 1963 DATE ISSUED 9-1-62 REVISED(•)

GROUND CLEARANCE DIMENSIONS

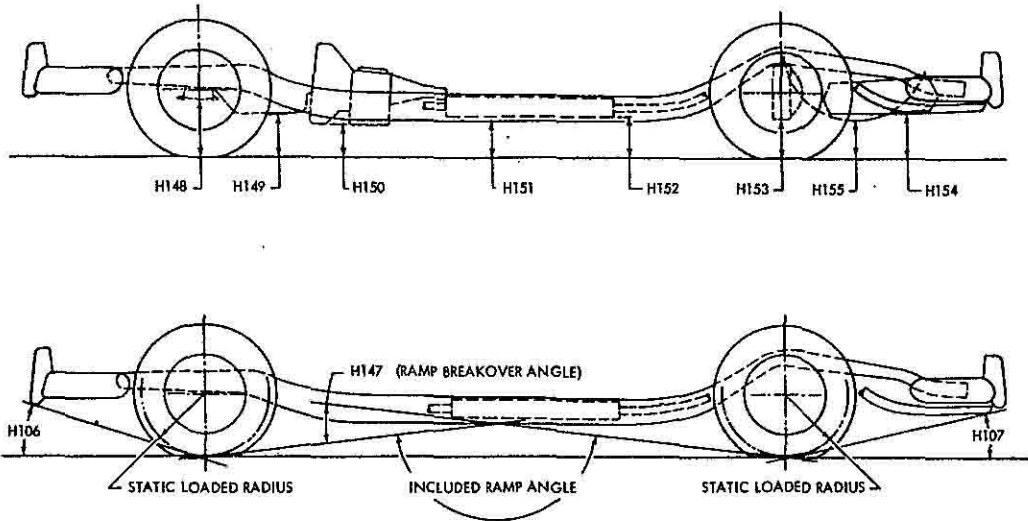

MODEL	Ref. No.	3200	3235-45	3500	3535	38
Angle of approach	H106	25° 51'	25° 19'	25° 51'	25° 19'	60° 18'
Angle of departure	H107	13° 14'	14° 50'	13° 14'	14° 50'	12° 42'
Ramp breakover angle	H147	11° 45'	13° 18'	11° 45'	13° 18'	11° 36'
Front suspension to ground	H148	6.69	6.75	6.69	6.75	6.93
Oil pan to ground	H149	6.01	6.13	6.01	6.13	6.24
Flywheel housing to ground	H150	6.15	6.39	6.15	6.39	6.39
Frame structure to ground	H151	5.93	5.93	5.93	5.93	6.17
Exhaust system to ground	H152	6.11	6.83	6.11	6.83	6.23
Rear axle differential to ground	H153	6.53	6.53	6.53	6.53	6.77
Fuel tank to ground	H154	7.72	8.30	7.72	8.30	7.96
Spare tire well to ground	H155	-	9.21	-	-	-
Minimum running ground clearance	H156	5.93	5.93	5.93	5.93	6.17

AMA Specifications—Passenger Car

MAKE OF CAR Oldsmobile MODEL YEAR 1963 DATE ISSUED 9-1-62 REVISED (*)

FRONT COMPARTMENT DIMENSIONS

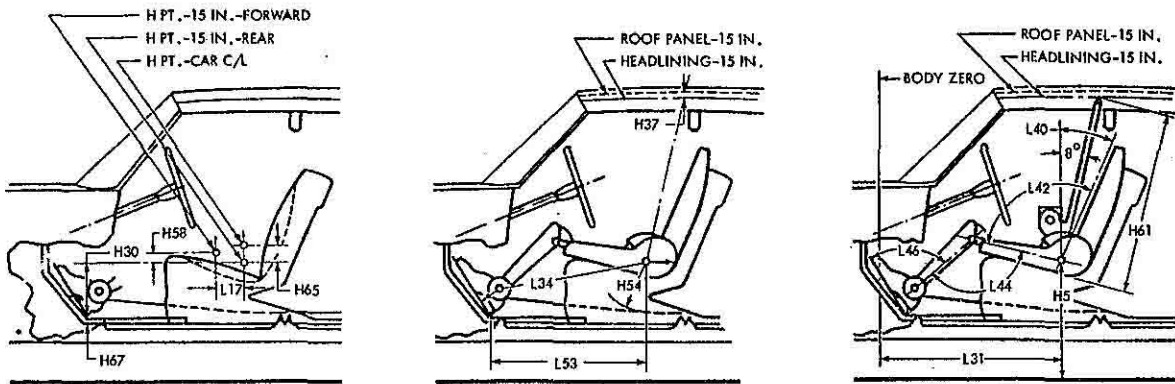

MODEL	Ref. No.	3239	3247	3267	3269	3235-45	3539	3547	3569
H Point to body zero line	L31a	41.2	41.3	41.3	41.2	41.2	41.2	41.3	41.2
H Point to ground	H5a	21.1	21.0	21.0	21.1	21.7	21.1	21.0	21.1
Effective head room	H61a	38.0	37.6	38.6	38.8	39.0	38.0	37.6	38.8
Headlining to roof height	H37	.50	.50	0	.50	.70	.50	.50	.50
Maximum effective leg room - accelerator	L34a	40.6	40.6	40.6	40.6	40.6	40.6	40.6	40.6
H Point to heel point	H30a	9.5	9.6	9.6	9.5	9.5	9.5	9.6	9.5
Depressed floor covering thickness	H67a	N. A.	N. A.	N. A.	N. A.	N. A.	N. A.	N. A.	N. A.
Back angle	L40a	30°	28°	28°	30°	30°	30°	28°	30°
Hip angle	L42a	107°	106°	106°	107°	107°	107°	106°	107°
Knee angle	L44a	140°	139°	139°	140°	140°	140°	139°	140°
Foot angle	L46a	111°	117°	117°	111°	111°	111°	117°	111°
H Point differential, side to center	H65a	.30	.30	.30	.30	.30	.30	.30	.30
H Point to tunnel	H54a	7.5	7.4	7.4	7.5	7.5	7.5	7.4	7.5
H Point to accelerator floor point	L53a	33.0	33.0	33.0	33.0	33.0	33.0	33.0	33.0
H Point travel	L17a	4.8	4.8	4.8	4.8	4.8	4.8	4.8	4.8
H Point rise	H58a	.70	.70	.70	.70	.70	.70	.70	.70

AMA Specifications—Passenger Car

MAKE OF CAR Oldsmobile MODEL YEAR 1963 DATE ISSUED 9-1-62 REVISED (*)

FRONT COMPARTMENT DIMENSIONS

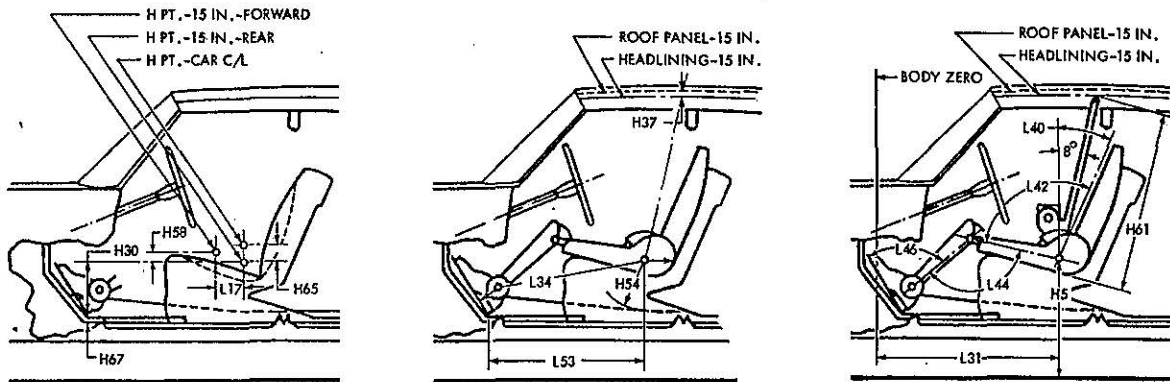

MODEL	Ref. No.	3535	3657	3667	3819	3829	3839	3847	3867	3947
H Point to body zero line	L31a	41.2	42.2	42.2	41.7	41.7	41.7	41.2	41.2	41.2
H Point to ground	H5a	21.7	20.6	20.8	20.5	20.5	20.5	20.7	20.7	20.9
Effective head room	H61a	39.0	37.6	39.1	40.0	40.0	38.6	38.4	39.3	38.2
Headlining to roof height	H37	.70	.80	0	.50	.50	.50	.50	0	.50
Maximum effective leg room - accelerator	L34a	40.6	41.5	41.5	41.1	41.1	41.1	40.5	40.5	41.6
H Point to heel point	H30a	9.5	9.1	9.1	8.8	8.8	8.8	9.1	9.1	9.2
Depressed floor covering thickness	H67a	N. A.	N. A.	N. A.	N. A.	N. A.	N. A.	N. A.	N. A.	N. A.
Back angle	L40a	30°	26°	26°	24°	24°	24°	25°	25°	26°
Hip angle	L42a	107°	103°	103°	98°	98°	98°	98°	98°	103°
Knee angle	L44a	140°	142°	142°	137°	137°	137°	132°	132°	141°
Foot angle	L46a	111°	125°	125°	124°	124°	124°	121°	121°	126°
H Point differential, side to center	H65a	.30	-	-	.20	.20	.20	.40	.40	-
H Point to tunnel	H54a	7.5	-	-	6.6	6.6	6.6	7.1	7.1	-
H Point to accelerator floor point	L53a	33.0	33.8	33.8	33.5	33.5	33.5	32.9	32.9	34.0
H Point travel	L17a	4.8	4.8	4.8	4.8	4.8	4.8	4.8	4.8	4.8
H Point rise	H58a	.70	.60	.60	.70	.70	.70	.70	.70	.60

AMA Specifications – Passenger Car

MAKE OF CAR Oldsmobile MODEL YEAR 1963 DATE ISSUED 9-1-62 REVISED (6)

REAR COMPARTMENT DIMENSIONS

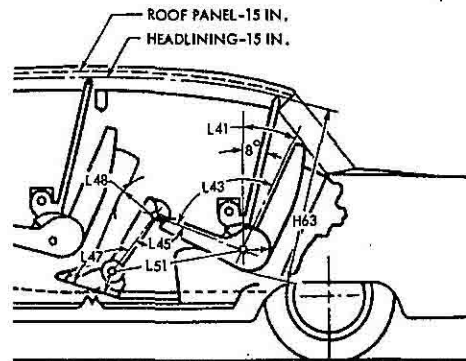
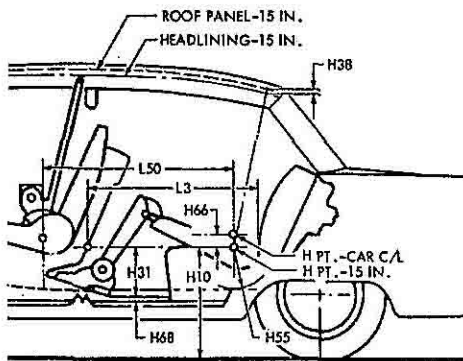

MODEL	Ref. No.	3239	3247	3267	3269	3235-45	3539	3547	3569	3535
H Point couple distance	L50a	35.1	34.2	33.7	36.1	35.3	35.1	34.2	36.1	35.3
H Point to ground	H10a	20.1	18.9	18.9	20.3	22.3	20.1	18.9	20.3	22.3
Effective head room	H63a	37.3	38.0	38.0	37.6	38.7	37.3	38.0	37.6	38.7
Headlining to roof height	H38	.60	.40	0	1.0	.70	.60	.50	1.0	.70
Minimum effective leg room	L51a	37.4	35.7	35.2	38.7	38.0	37.4	35.7	38.7	38.0
H Point to heel point	H31a	11.1	10.1	10.1	11.3	13.2	11.1	10.0	11.3	13.2
Depressed floor covering thickness	H68a	N. A.	N. A.	N. A.	N. A.	N. A.	N. A.	N. A.	N. A.	N. A.
Minimum knee room	L48a	4.3	4.0	3.7	5.2	4.2	4.3	4.0	5.2	4.2
Rear compartment room	L3	27.6	26.6	26.2	28.4	29.2	27.6	26.5	28.2	29.2
Back angle	L41a	24°	18°	18°	25°	24°	24°	18°	25°	24°
Hip angle	L43a	90°	78°	77°	94°	94°	90°	78°	94°	94°
Knee angle	L45a	104°	95°	93°	111°	107°	104°	95°	111°	107°
Foot angle	L47a	123°	122°	121°	127°	122°	123°	122°	127°	122°
H Point differential, side to center	H66a	1.0	1.3	1.1	.70	.70	1.0	1.3	.70	.70
H Point to tunnel	H55a	6.2	5.3	5.1	6.0	7.0	6.2	5.3	6.0	7.0

AMA Specifications – Passenger Car

MAKE OF CAR Oldsmobile MODEL YEAR 1963 DATE ISSUED 9-1-62 REVISED(•)

REAR COMPARTMENT DIMENSIONS

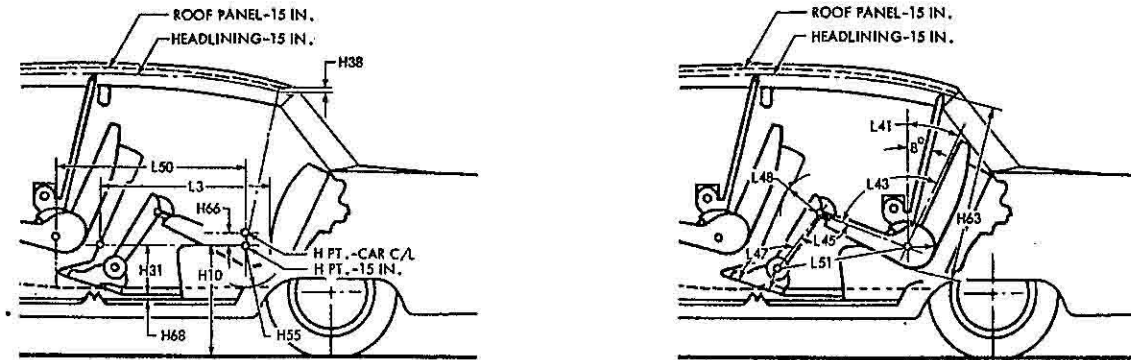

MODEL	Ref. No.	3657	3667	3819	3829	3839	3847	3867	3947
H Point couple distance	L50a	33.3	32.8	38.7	38.7	36.4	37.0	37.0	36.0
H Point to ground	H10a	18.9	18.9	20.4	20.4	19.3	19.4	19.2	19.4
Effective head room	H63a	38.1	38.0	38.7	38.7	38.1	38.0	37.9	38.0
Headlining to roof height	H38	.80	0	.50	.50	.40	.50	0	.50
Minimum effective leg room	L51a	35.8	35.4	41.1	41.1	39.6	39.0	38.9	38.8
H Point to heel point	H31a	9.6	9.5	11.2	11.2	10.1	10.2	10.0	10.2
Depressed floor covering thickness	H68a	N. A.	N. A.	N. A.	N. A.	N. A.	N. A.	N. A.	N. A.
Minimum knee room	L48a	4.2	3.9	8.3	8.3	6.4	6.4	6.4	6.5
Rear compartment room	L3	26.3	26.1	31.5	31.5	29.4	29.6	29.1	29.3
Back angle	L41a	18°	18°	25°	25°	20°	20°	20°	20°
Hip angle	L43a	78°	77°	100°	100°	89°	87°	87°	87°
Knee angle	L45a	96°	94°	127°	127°	116°	113°	113°	112°
Foot angle	L47a	125°	124°	132°	132°	131°	131°	131°	131°
H Point differential, side to center	H66a	1.3	1.1	.80	.80	1.1	1.4	1.2	1.4
H Point to tunnel	H55a	5.3	5.1	5.9	5.9	5.3	5.6	5.2	5.6

AMA Specifications – Passenger Car

MAKE OF CAR Oldsmobile MODEL YEAR 1963 DATE ISSUED 9-1-62 REVISED(•)

SEAT AND ENTRANCE DIMENSIONS

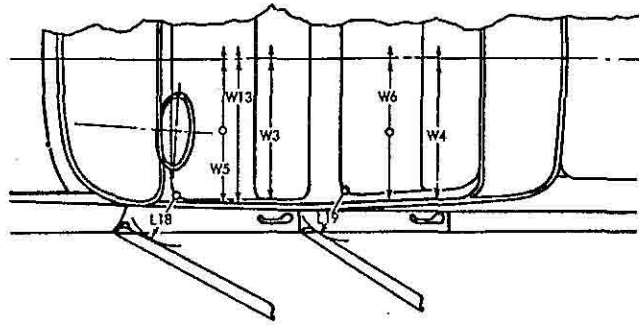
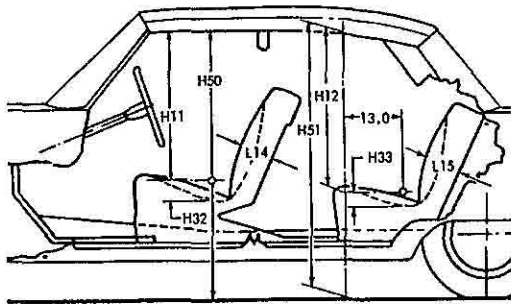

MODEL	Ref. No.	3239	3247	3267	3269	3235-45	3539	3547	3569	3535
Shoulder room - front	W3a	58.8	58.8	58.8	58.8	58.8	58.8	58.8	58.9	58.9
Hip room - front	W5a	63.3	63.4	63.4	63.3	63.3	63.1	63.0	63.1	63.1
Seat width - front	W16a	57.6	57.6	57.6	57.6	57.6	57.6	57.6	57.6	57.6
Upper body opening to ground - front	H50a	50.9	49.7	49.3	50.7	51.3	50.9	49.7	50.7	51.3
Entrance height - front	H11a	29.8	28.6	28.2	29.6	29.6	29.8	28.6	29.6	29.6
Entrance foot clearance - front	L18	14.4	14.4	14.4	14.4	14.4	14.4	14.4	14.4	14.4
Seat cushion deflection - front	H32a	3.9	3.9	3.9	3.9	3.9	3.9	3.4	3.9	3.9
Seat back thickness - front	L14	7.0	7.0	7.0	7.0	7.0	7.5	7.5	7.5	7.5
Shoulder room - rear	W4a	57.9	57.7	51.5	57.9	57.9	57.9	57.5	58.0	57.9
Hip room - rear	W6a	63.5	55.2	51.6	63.4	63.3	63.5	55.2	63.0	63.3
Upper body opening to ground - rear	H51a	53.3	-	-	50.4	51.3	54.3	-	50.4	51.3
Entrance height - rear	H12a	30.2	-	-	30.2	29.0	30.2	-	30.2	29.0
Entrance foot clearance - rear	L19	11.6	10.1	10.1	11.7	14.4	11.5	10.3	11.7	14.4
Seat cushion deflection - rear	H33a	4.3	4.3	4.6	3.4	1.9	4.3	4.4	4.1	1.9
Seat back thickness - rear	L15	8.1	7.3	7.6	7.7	5.5	8.1	7.3	7.7	5.5

AMA Specifications – Passenger Car

MAKE OF CAR Oldsmobile MODEL YEAR 1963 DATE ISSUED 9-1-62 REVISED(•)

SEAT AND ENTRANCE DIMENSIONS

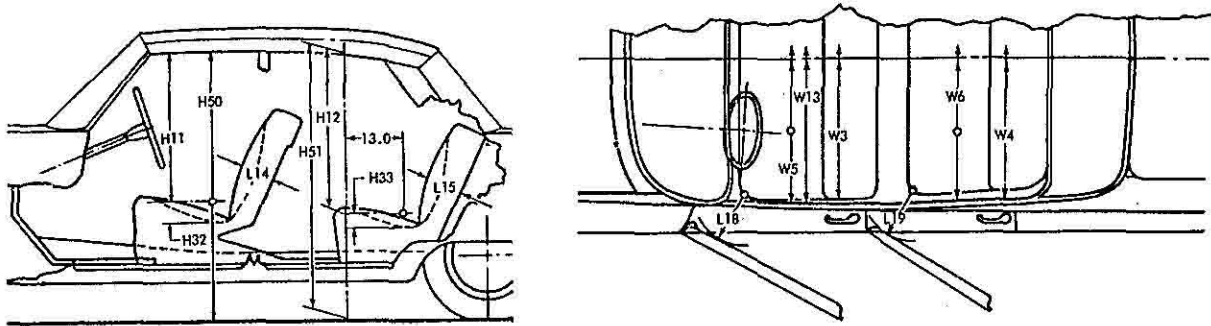

MODEL	Ref. No.	3657	3667	3819	3829	3839	3847	3867	3947
Shoulder room - front	W3a	58.7	58.7	58.6	58.6	58.8	58.8	58.8	58.8
Hip room - front	W5a	63.6	63.6	63.7	63.7	63.7	63.5	63.3	63.2
Seat width - front	W16a	56.2	56.2	57.7	57.7	57.7	57.7	57.7	56.2
Upper body opening to ground - front	H50a	50.8	49.4	51.6	51.8	50.6	50.6	49.6	50.5
Entrance height - front	H11a	30.2	28.6	31.2	31.3	30.1	29.8	28.8	29.6
Entrance foot clearance - front	L18	15.3	15.3	14.5	14.5	14.5	14.5	14.5	15.3
Seat cushion deflection - front	H32a	3.6	3.6	5.0	5.0	5.0	5.0	5.0	3.6
Seat back thickness - front	L14	6.4	6.4	7.5	7.5	7.5	7.5	7.5	6.4
Shoulder room - rear	W4a	57.5	51.5	58.1	58.0	58.1	57.6	51.4	57.6
Hip room - rear	W6a	55.1	51.6	63.1	62.5	63.7	54.8	51.3	54.8
Upper body opening to ground - rear	H51a	-	-	51.4	51.4	49.6	-	-	-
Entrance height - rear	H12a	-	-	31.0	31.1	30.2	-	-	-
Entrance foot clearance - rear	L19	9.9	9.9	13.7	13.9	12.8	11.2	11.9	11.0
Seat cushion deflection - rear	H33a	4.0	4.2	4.1	4.1	4.3	4.2	4.5	3.7
Seat back thickness - rear	L15	7.6	7.6	7.6	7.6	7.4	7.3	7.6	7.6

AMA Specifications – Passenger Car

MAKE OF CAR Oldsmobile MODEL YEAR 1963 DATE ISSUED 9-1-62 REVISED(•)

VISION AND CONTROL DIMENSIONS

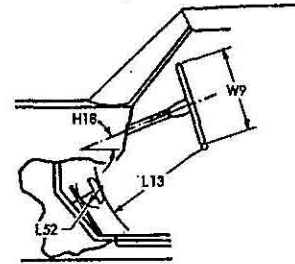
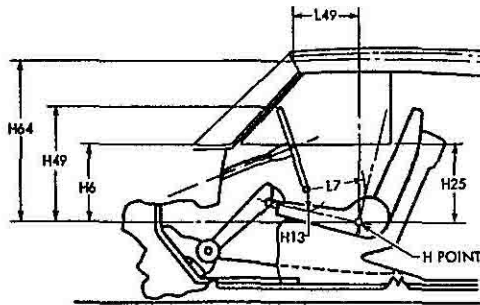

MODEL	Ref. No.	3239	3247	3267	3269	3235-45	3539	3547	3569	3535
H Point to windshield bottom DLO	H6a	18.5	18.6	18.6	18.5	18.5	18.5	18.6	18.5	18.5
H Point to windshield upper DLO	H64a	30.6	31.4	31.3	32.4	32.4	30.6	31.4	32.4	32.4
H Point to windshield upper DLO	L49a	13.7	12.9	12.9	10.7	10.7	13.7	12.9	10.7	10.7
Belt height - front	H25a	16.3	16.4	16.4	16.3	16.3	16.3	16.4	16.3	16.3
Steering wheel center to centerline of car	W7	15.9	15.9	15.9	15.9	15.9	15.9	15.9	15.9	15.9
Steering wheel maximum outside diameter	W9	17.0	17.0	17.0	17.0	17.0	17.0	17.0	17.0	17.0
Steering column angle - horizontal	H18	28°	28°	28°	28°	28°	28°	28°	28°	28°
H Point to top of steering wheel	H49a	22.5	22.6	22.6	22.5	22.5	22.5	22.6	22.5	22.5
Steering wheel torso clearance	L7a	10.5	10.5	10.5	10.5	10.5	10.5	10.5	10.5	10.5
Steering wheel thigh clearance	H13a	5.4	5.4	5.4	5.4	5.4	5.4	5.4	5.4	5.4
Brake pedal knee clearance	L13	24.3	24.3	24.3	24.3	24.3	24.3	24.3	24.3	24.3
Brake pedal to accelerator	L52a	-4.7	-4.7	-4.7	-4.7	-4.7	-4.7	-4.7	-4.7	-4.7
Tumble-home	W122a	11.8°	11.8°	11.8°	11.8°	11.8°	11.8°	11.8°	11.8°	11.8°

AMA Specifications – Passenger Car

MAKE OF CAR Oldsmobile MODEL YEAR 1963 DATE ISSUED 9-1-62 REVISED(•)

VISION AND CONTROL DIMENSIONS

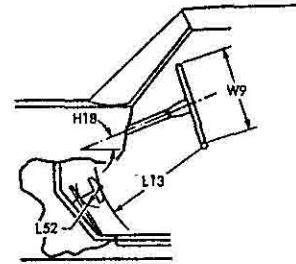
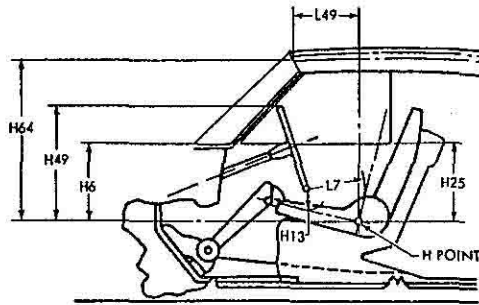

MODEL	Ref. No.	3657	3667	3819	3829	3839	3847	3867	3947
H Point to windshield bottom DLO	H6a	19.0	19.0	19.3	19.3	19.3	19.1	19.1	19.0
H Point to windshield upper DLO	H64a	31.0	31.7	33.4	33.4	32.1	31.9	31.8	31.7
H Point to windshield upper DLO	L49a	14.6	13.8	11.2	11.2	13.3	12.8	12.8	13.8
Belt height - front	H25a	16.8	16.8	17.2	17.2	17.2	16.9	16.9	16.8
Steering wheel center to centerline of car	W7	15.9	15.9	15.9	15.9	15.9	15.9	15.9	15.9
Steering wheel maximum outside diameter	W9	17.0	17.0	16.0	16.0	16.0	16.0	16.0	16.0
Steering column angle - horizontal	H18	28 °	28 °	28 °	28 °	28 °	28 °	28 °	28 °
H Point to top of steering wheel	H49a	22.9	22.9	22.9	22.9	22.9	22.6	22.6	22.5
Steering wheel torso clearance	L7a	11.4	11.4	11.4	11.4	11.4	10.9	10.9	11.8
Steering wheel thigh clearance	H13a	5.5	5.5	5.9	5.9	5.9	5.4	5.4	5.8
Brake pedal knee clearance	L13	24.2	24.2	27.5	27.5	27.5	27.5	27.5	27.5
Brake pedal to accelerator	L52a	-1.5	-1.5	-1.5	-1.5	-1.5	-1.5	-1.5	-1.5
Tumble-home	W122a	11.8 °	11.8 °	11.8 °	11.8 °	11.8 °	11.8 °	11.8 °	11.8 °

AMA Specifications – Passenger Car

MAKE OF CAR OLDSMOBILE MODEL YEAR 1963 DATE ISSUED 9-1-62 REVISED(*)

LUGGAGE COMPARTMENT

MODEL	Ref. No.	32	35	38	39
Usable luggage capacity (See instructions)		17.1		19.7	
Liftover height*	H301a	27.7		21.9	
Position of spare tire storage		On Shelf on all except Conv. & S. W. that are in Well of Trunk			
Method of holding lid open		Counter Balance Torsion Bar			

THIRD SEAT DIMENSIONS

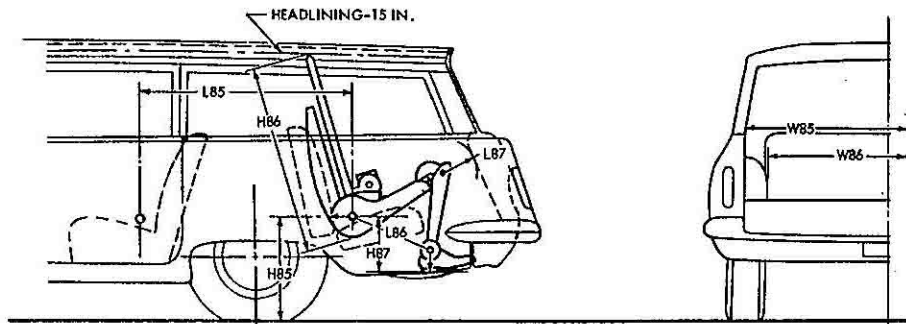

MODEL	Ref. No.	3245
Seat facing direction		Back
Shoulder room	W85a	49.2
Hip room	W86a	37.4
H Point couple distance	L85a	43.1
H Point to ground	H85a	22.6
Effective head room	H86a	38.6
Effective leg room	L86a	29.2
H Point to heel point	H87a	12.0
Knee room	L87a	8.2
Back angle	L88a	21°
Hip angle	L89a	79°
Knee angle	L90a	67°
Foot angle	L91a	98°

* Vertical dimension from luggage compartment lower opening to ground.

AMA Specifications—Passenger Car

MAKE OF CAR Oldsmobile MODEL YEAR 1963 DATE ISSUED 9-1-62 REVISED(*)

STATION WAGON—CARGO SPACE DIMENSIONS

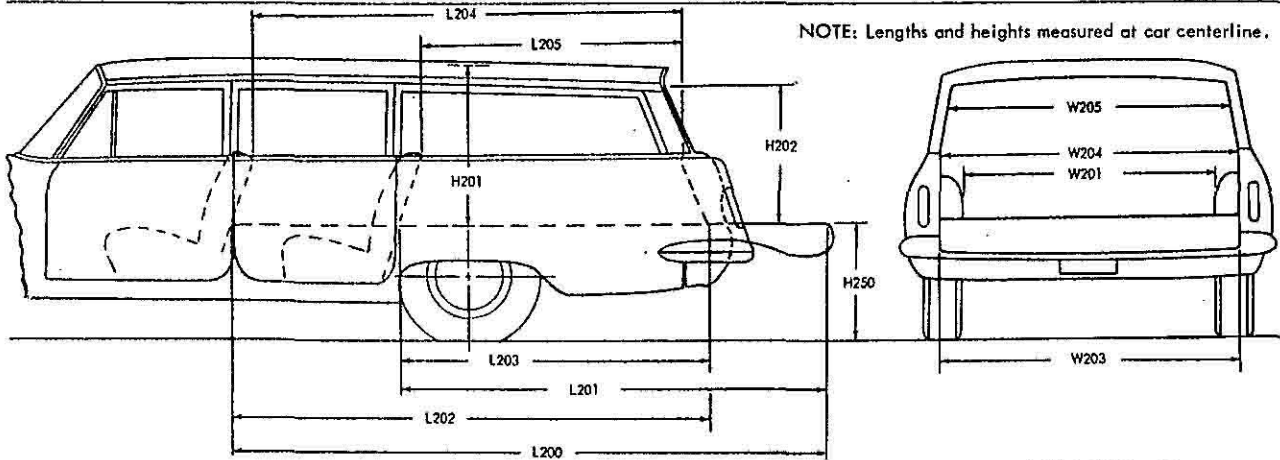

MODEL	Ref. No.	3235	3245	3535
Floor length from back of front seat at floor level to end of lowered tail gate or floor	L200	124.1	124.1	124.1
Floor length from back of second seat at floor level to end of lowered tail gate or floor	L201	89.5	89.5	89.5
Floor length from back of front seat at floor level to inside of closed tail gate	L202	92.6	92.6	92.6
Floor length from back of second seat at floor level to inside of closed tail gate	L203	58.1	58.1	58.1
Minimum horizontal distance from top rear of front seat back to inside of tail gate at belt	L204	82.8	82.8	82.8
Minimum horizontal distance from top rear of second seat back to inside of tail gate at belt	L205	46.2	46.2	46.2
Maximum width of cargo space at floor - specify location	W200a	62.1	62.1	62.1
Minimum distance between wheel houses at floor level	W201	48.5	48.5	48.5
Rear end opening width at floor	W203	54.4	48.8	54.4
Rear end opening width at belt	W204	54.7	54.7	54.7
Maximum width of rear opening above belt	W205	54.2	54.2	54.2
Maximum height - floor covering to headlining at centerline of rear axle	H201	31.2	31.2	31.2
Maximum height of rear opening - tail and lift gates open	H202	30.4	30.4	30.4
Platform height from ground to top of tail gate floor covering at rear most edge of tail gate - curb weight	H250	29.5	29.5	29.5
Rear end closure (e.g., one piece door, hinged left - sliding glass, drop tail gate)		Drop Tail Gate		
Cargo volume index (cu. ft.) W4 x L204 x H201		86.6	86.6	86.6

1728

AMA Specifications – Passenger Car

MAKE OF CAR Oldsmobile MODEL YEAR 1963 DATE ISSUED 9-1-62 REVISED (e)

MODEL _____

BODY—MISCELLANEOUS INFORMATION

Drs. hinged (front, rear)	Front doors		Front
	Rear doors		Front
Type of finish (lacquer, enamel, other)			Lacquer
Hood hinge location (front, rear)			Rear
Hood counterbalanced (yes, no)			Yes
Hood release control (internal, external)			External
Vehicle (Serial) No. Location		L. H. Front Pillar Post	
Engine No. Location		None	
Theft protection - type		Key Type Starting	
Vent window control method (crank, friction pivot)	Front	Crank	
	Rear	None	
Seat cushion type	Front	Zig Zag	
	Rear	" "	
Seat back type	Front	" "	
	Rear	" "	
Windshield type (single curved, compound curved, other)		Compound Curve	
Rear window type (flat, curved, one piece, three piece)		Curved - One Piece	
Side glass type (curved, flat)		Flat	
Side glass exposed surface area		See Below "A"	
Windshield glass exposed surface area		" " "B"	
Backlight glass exposed surface area		" " "C"	
Total glass exposed surface area		" " "D"	

		3200	3500	3600	3800	3900
4 Door Sedan	(A)	1338.4	1338.4		1221.1	
	(B)	1654.2	1654.2		1654.2	
	(C)	1425.5	1425.5		1800.9	
	(D)	4418.1	4418.1		4676.2	
4 Door Hardtop Sedan (4) Window	(A)	1464.8	1464.8		1442.8	
	(B)	1468.0	1468.0		1522.6	
	(C)	1299.9	1299.9		1289.4	
	(D)	4232.7	4232.7		4254.8	
4 Door Hardtop Sedan (6) Window	(A)				1897.3	
	(B)				1654.2	
	(C)				1221.1	
	(D)				4772.6	
2 Door Hardtop Coupe	(A)	1336.8	1336.8	1401.2	1449.6	1449.6
	(B)	1522.6	1522.6	1468.0	1522.6	1522.6
	(C)	994.7	994.7	1336.4	1289.4	1289.4
	(D)	3854.1	3854.1	4205.6	4261.6	4261.6
2 Door Convertible	(A)	1208.6		1208.6	1285.6	
	(B)	1522.6		1522.6	1522.6	
	(C)	1350.0		1350.0	1350.0	
	(D)	4081.2		4081.2	4158.2	
Station Wagon	(A)	2856.2	2856.2			
	(B)	1654.2	1654.2			
	(C)	991.0	991.0			
	(D)	5501.4	5501.4			

DIMENSION DEFINITIONS

- W3a SHOULDER ROOM - FRONT. The minimum lateral dimension between the door garnish moldings or nearest interference. Measured at H Point station.
- W4a SHOULDER ROOM - REAR. Measured in the same manner as W3a.
- W5a HIP ROOM - FRONT. The lateral dimension through H Point to trimmed surfaces.
- W6a HIP ROOM - REAR. Measured in the same manner as W5a.
- W7 STEERING WHEEL CENTER TO CENTERLINE OF CAR. Measured horizontally from steering wheel center to centerline of car. The point at steering wheel center is located in the surface plane of wheel.
- W9 STEERING WHEEL MAXIMUM OUTSIDE DIAMETER. Define if other than round.
- W16a SEAT WIDTH - FRONT. The maximum trimmed width of front seat cushion.
- W85a SHOULDER ROOM - THIRD SEAT. Measured in the same manner as W3a.
- W86a HIP ROOM - THIRD SEAT. Measured in the same manner as W5a.
- W101 TREAD - FRONT. Measured at centerline of tires, with nominal camber, at ground.
- W102 TREAD - REAR. Measured at centerline of tires at ground.
- W103 MAXIMUM OVERALL CAR WIDTH. Include bumpers, moldings, or sheet metal protrusions.
- W106 FRONT FENDER OVERALL WIDTH. Measured at centerline of front wheels, excluding moldings.
- W107 REAR FENDER OVERALL WIDTH. Measured at centerline of rear wheels, excluding moldings.
- W116 MAXIMUM OVERALL BODY WIDTH. Measured across body, excluding hardware and applied moldings, but including fenders when integral with body.
- W117 MAXIMUM BODY WIDTH AT #2 PILLAR. Measured across body at #2 pillar, excluding hardware and applied moldings.
- W120a MAXIMUM OVERALL CAR WIDTH, FRONT DOORS OPEN. Measured with front doors in maximum hold-open position.
- W121a MAXIMUM OVERALL CAR WIDTH, REAR DOORS OPEN. Measured in same manner as W120a.
- W122a TUMBLE-HOME. The angle from vertical to the front door glass outer surface or the chord of a curved door glass, measured at the front H Point station.
- L3 REAR COMPARTMENT ROOM. The horizontal dimension from the back of front seat to front of rear seat back at a height tangent to the top of rear seat cushion.
- L7a STEERING WHEEL TORSO CLEARANCE. The minimum distance from the back edge of steering wheel, in straight-ahead position, to the Torso Line.
- L13 BRAKE PEDAL KNEE CLEARANCE. The minimum dimension from the lower edge of the steering wheel to the brake pedal face centerline.
- L14 SEAT BACK THICKNESS - FRONT. The maximum thickness of the seat back, excluding bolsters.
- L15 SEAT BACK THICKNESS - REAR. Measured in the same manner as L14.
- L17a H POINT TRAVEL. The horizontal dimension between the H Point in the most forward and rearward seat positions.
- L18 ENTRANCE FOOT CLEARANCE - FRONT. The minimum horizontal dimension between seat and normal line of door or pillar at a height between the sill plate bead and 4.0 inches above the bead. Door should be in the maximum hold-open position.
- L19 ENTRANCE FOOT CLEARANCE - REAR. Measured in the same manner as L18 on four-door models. On two-door styles, the minimum dimension between rear corner of front seat, with front seat back tilted forward, and trimmed lock pillar, built-in quarter armrest panel, or rear seat cushion at a height between the sill plate bead and 4.0 inches above the bead.
- L30 BODY ZERO LINE TO ACTUAL FRONT OF DASH. If actual front of dash is to the rear of Body Zero Line, it is identified by a minus (-) sign.
- L31a H POINT TO BODY ZERO LINE - FRONT. Horizontal dimension.
- L34a MAXIMUM EFFECTIVE LEG ROOM - ACCELERATOR. Measured along a diagonal line from ankle pivot center to H Point plus a constant of 10.0 inches. Measured with the right foot on accelerator pedal.
- L40a BACK ANGLE - FRONT. The angle between a vertical line through the H Point and the Torso Line.
- L41a BACK ANGLE - REAR. Measured in the same manner as L40a.
- L42a HIP ANGLE - FRONT. The angle between Torso Line and a line extending from knee pivot center to H Point.
- L43a HIP ANGLE - REAR. Measured in the same manner as L42a.
- L44a KNEE ANGLE - FRONT. The angle between a line from H Point to knee pivot center and a line from the knee pivot center to the ankle pivot center.
- L45a KNEE ANGLE - REAR. Measured in the same manner as L44a.
- L46a FOOT ANGLE - FRONT. The angle between a line extended from the knee pivot center through the ankle pivot center and a line tangent to the sole and heel of manikin bare foot.
- L47a FOOT ANGLE - REAR. Measured in the same manner as L46a.
- L48a MINIMUM KNEE ROOM - REAR. The minimum dimension from the knee pivot center to the back of front seat back.
- L49a H POINT TO WINDSHIELD UPPER DLO. The horizontal dimension from H Point to the point of tangency of horizontal line of vision (described in dimension H64a) with body upper structure.

DIMENSION DEFINITIONS (cont.)

L50a H POINT COUPLE DISTANCE. The horizontal dimension from the front seat H Point to the rear seat H Point.

L51a MINIMUM EFFECTIVE LEG ROOM – REAR. Measured along a diagonal line from ankle pivot center to H Point plus a constant of 10.0 inches. Measured with the foot positioned to nearest interference between seat structure and toe, instep or lower leg.

L52a BRAKE PEDAL TO ACCELERATOR. The minimum dimension from center of brake pedal face to accelerator. Measured in the side view.

L53a H POINT TO ACCELERATOR FLOOR POINT. The horizontal dimension from intersection of accelerator and depressed floor covering to the H Point.

L85a H POINT COUPLE DISTANCE – THIRD SEAT. The horizontal dimension from the second seat H Point to the third seat H Point.

L86a EFFECTIVE LEG ROOM – THIRD SEAT. Measured in the same manner as L51a. With rear-facing third seat, foot is positioned in foot well or to nearest interference with rear end or rear closure.

L87a KNEE ROOM – THIRD SEAT. Measured in the same manner as L48a. With rear-facing third seat, dimension is measured to rear closure.

L88a BACK ANGLE – THIRD SEAT. Measured in the same manner as L40a.

L89a HIP ANGLE – THIRD SEAT. Measured in the same manner as L42a.

L90a KNEE ANGLE – THIRD SEAT. Measured in the same manner as L44a.

L91a FOOT ANGLE – THIRD SEAT. Measured in the same manner as L46a.

L101 WHEELBASE.

L102 TIRE SIZE.

L103 OVERALL LENGTH. Include bumper guards if standard equipment.

L104 OVERHANG – FRONT. Measured from C/L of front wheels to front of car, including bumper guards if standard equipment.

L105 OVERHANG – REAR. Measured from C/L of rear wheels to rear of car, including bumper guards if standard equipment.

L123 BODY UPPER STRUCTURE LENGTH AT CAR CENTERLINE. The horizontal dimension from the theoretical intersection of extended windshield glass plane and normal cowl surface to the theoretical intersection of extended back window glass plane and normal deck surface; or in the case of a Fastback roof or Station Wagon, to back glass lower reveal molding, or rubber when molding is not used.

L127 BODY ZERO LINE TO CENTERLINE OF REAR WHEELS. A horizontal dimension.

L128a HOOD LENGTH AT CAR CENTERLINE. The horizontal dimension from the foremost point on sheet metal hood surface, excluding series identification or ornamentation, to the theoretical intersection of extended windshield glass plane and normal cowl surface.

L129a DECK LENGTH AT CAR CENTERLINE. The horizontal dimension from the rearmost point of the body sheet metal (visible above bumper), excluding series identification or ornamentation, to the theoretical intersection of extended back window glass plane and normal deck surface.

L130a BODY ZERO LINE TO WINDSHIELD COWL POINT. The horizontal dimension from body zero line to the theoretical intersection of extended windshield glass plane and normal cowl surface.

H5a H POINT TO GROUND – FRONT. Vertical dimension.

H6a H POINT TO WINDSHIELD BOTTOM DLO. Vertical dimension.

H10a H POINT TO GROUND – REAR. Vertical dimension.

H11a ENTRANCE HEIGHT – FRONT. The vertical dimension from H Point to upper trimmed body opening.

H12a ENTRANCE HEIGHT – REAR. The vertical dimension from H Point to the upper trimmed body opening at a section 13.0 inches forward of the H Point.

H13a STEERING WHEEL THIGH CLEARANCE. The minimum dimension from the bottom of steering wheel, in straight-ahead position, to centerline of thigh.

H18 STEERING COLUMN ANGLE – HORIZONTAL. The angle the centerline of steering column makes with the horizontal.

H25a BELT HEIGHT – FRONT. The vertical dimension from H Point to bottom of side window DLO.

H30a H POINT TO HEEL POINT – FRONT. The vertical dimension from the H Point to the manikin accelerator heel point on the depressed floor covering.

H31a H POINT TO HEEL POINT – REAR. The vertical dimension from the H Point to the manikin heel point on the depressed floor covering.

H32a SEAT CUSHION DEFLECTION – FRONT. The vertical dimension from a point on the undepressed seat cushion to the depressed seat cushion. Measured at the H Point station.

H33a SEAT CUSHION DEFLECTION – REAR. Measured in the same manner as H32a.

H37 HEADLINING TO ROOF HEIGHT – FRONT. The dimension from the intersection of the headlining and the extended effective head room line to the roof panel. Measured perpendicularly to the roof panel.

H38 HEADLINING TO ROOF HEIGHT – REAR. Measured in the same manner as H37.

H49a H POINT TO TOP OF STEERING WHEEL. The vertical dimension from the H Point to top of steering wheel, in straight-ahead position.

H50a UPPER BODY OPENING TO GROUND – FRONT. The vertical dimension from a point on the trimmed body opening to the ground. Measured at the H Point station.

DIMENSION DEFINITIONS (cont.)

- H51a UPPER BODY OPENING TO GROUND - REAR. The vertical dimension from a point on the trimmed body opening to the ground. Measured 13.0 inches forward of the H Point.
- H54a H POINT TO TUNNEL - FRONT. The minimum dimension from the H Point, at car centerline, to top of tunnel.
- H55a H POINT TO TUNNEL - REAR. Measured in the same manner as H54a.
- H58a H POINT RISE. The vertical dimension between the H Point in the most forward and rearward seat positions.
- H61a EFFECTIVE HEAD ROOM - FRONT. The dimension from H Point to the headlining, plus a constant of 4.0 inches. Measured along a line 8° to rear of vertical.
- H63a EFFECTIVE HEAD ROOM - REAR. Measured in the same manner as H61a.
- H64a H POINT TO WINDSHIELD UPPER DLO. Vertical dimension from H Point to highest horizontal line of vision through windshield at 15 inch section.
- H65a H POINT DIFFERENTIAL, SIDE TO CENTER - FRONT. The vertical dimension from side occupant H Point to center occupant H Point.
- H66a H POINT DIFFERENTIAL, SIDE TO CENTER - REAR. Measured in the same manner as H65a.
- H67a DEPRESSED FLOOR COVERING THICKNESS - FRONT. The vertical dimension from manikin accelerator heel point normally to underbody sheet metal immediately below heel point.
- H68a DEPRESSED FLOOR COVERING THICKNESS - REAR. Measured same as H67a.
- H85a H POINT TO GROUND - THIRD SEAT. Vertical dimension.
- H86a EFFECTIVE HEAD ROOM - THIRD SEAT. Measured in the same manner as H61a.
- H87a H POINT TO HEEL POINT - THIRD SEAT. Measured in the same manner as H31a.
- H101 OVERALL HEIGHT. Measured with full design load.
- H102 FRONT BUMPER TO GROUND. Minimum dimension.
- H104 REAR BUMPER TO GROUND. Minimum dimension.
- H106 ANGLE OF APPROACH. Minimum angle between ground and a line tangent to arc of front tire static loaded radius and touching the limiting point of interference on front bumper, bumper guard, or gravel deflector.
- H107 ANGLE OF DEPARTURE. Minimum angle between ground and a line tangent to arc of rear tire static loaded radius and touching the limiting point of interference on rear bumper, bumper guard, gravel deflector, tail pipe, fender or other interfering structure.
- H111 ROCKER PANEL TO GROUND - REAR. The vertical dimension from ground to bottom of rocker panel, excluding flanges. Measured at front of rear wheel opening.
- H112a ROCKER PANEL TO GROUND - FRONT. The vertical dimension from ground to bottom of rocker panel, excluding flanges. Measured at foremost point of rocker panel.
- H114 HOOD AT REAR TO GROUND. Measured from hood opening line on shroud, exclusive of moldings.
- H115 STEP HEIGHT - FRONT (DESIGN LOAD). The vertical dimension from top of sill plate bead, at C/L of front door sill plate, to ground.
- H116 STEP HEIGHT - REAR (DESIGN LOAD). Measured in same manner as dimension H115.
- H122 WINDSHIELD SLOPE ANGLE. The angle between a vertical line and the windshield surface at car centerline. On compound-curved windshields the chord of the arc is used and limited to that section of the windshield comprehended by an 18-inch chord.
- H130 STEP HEIGHT - FRONT (CURB LOAD). The vertical dimension from top of sill plate, at C/L of front door sill plate, to ground.
- H131 STEP HEIGHT - REAR (CURB LOAD). Measured in same manner as H130.
- H132 BOTTOM OF DOOR TO GROUND, OPEN - FRONT. Measured from bottom outside corner of door with door in maximum hold-open position.
- H133 BOTTOM OF DOOR TO GROUND, CLOSED - FRONT. Same point on door as H132 dimension, with door closed.
- H134 BOTTOM OF DOOR TO GROUND, OPEN - REAR. Measured in same manner as H132.
- H135 BOTTOM OF DOOR TO GROUND, CLOSED - REAR. Measured in same manner as H133.
- H136a BODY ZERO TO GROUND - FRONT. A vertical dimension measured at front wheel centerline.
- H137a BODY ZERO TO GROUND - REAR. A vertical dimension measured at rear wheel centerline.
- H147 RAMP BREAKOVER ANGLE. Supplement of included ramp angle (180° minus included ramp angle) over which car can pass without interference; measured with car sitting on a level surface, using lines tangent to arcs of front and rear static loaded radii and intersecting at point on underside of car which defines the smallest angle.
- H148 FRONT SUSPENSION TO GROUND. Minimum clearance measured from lower control arm inner shaft or lowest point on the car centerline.
- H149 OIL PAN TO GROUND. Minimum clearance measured from sheet metal or drain plug.
- H150 FLYWHEEL/CONVERTER HOUSING AND TRANSMISSION ASSEMBLY TO GROUND. Minimum clearance.
- H151 FRAME STRUCTURE TO GROUND. Minimum clearance measured approximately midway between front and rear axles. In this measurement, cross bars and X-members shall be considered part of frame.
- H152 EXHAUST SYSTEM TO GROUND. Minimum clearance. Specify location.
- H153 REAR AXLE DIFFERENTIAL SYSTEM TO GROUND. Minimum clearance.
- H154 FUEL TANK TO GROUND. Minimum clearance measured from sheet metal or drain plug, but excluding supports or straps.
- H155 SPARE TIRE WELL TO GROUND. Minimum clearance.
- H156 MINIMUM RUNNING GROUND CLEARANCE. Location of measurement on the car is to be clearly recorded.

INDEX

SUBJECT	PAGE NO.	SUBJECT	PAGE NO.
Angles of Approach, Departure	25	Lamp Bulbs	13
Automatic Transmission	1, 16	Lamp Height & Spacing	14
Axis, Steering	21	Legroom	26, 27, 30
Axle, Rear	1, 17	Lengths - Overall	1, 23
Battery	10	Lifters, Valve	5
Bearings, Engine	4, 5, 6	Linings - Clutch, Brake	15, 19
Belts - Fan, Generator, Water Pump	9	Lubrication	6, 7, 15, 16, 17
Body - General Information, types	Title, 1, 22, 32	Motor, Starting	10
Exterior Dimensions	1, 22, 23, 24	Muffler	7
Interior Dimensions	26, 27, 28, 29, 30	Overdrive	16
Clearance Dimensions	25	Piston Pins & Rings	2, 4
Brakes - Parking, Service, Power	18, 19	Pistons	2
Camber	21	Power Brakes	18
Camshaft	5	Power Steering	20
Capacities		Power Teams	3
Cooling System	9	Propeller Shaft, Universal Joints	16, 17
Fuel Tank	8	Pumps - Oil, Fuel	7, 8
Lubricants		Water	9
Engine Crankcase	7	Radiator, Hoses	9
Transmission and Overdrive	15, 16	Ramp Break-over Angle	25
Rear Axle	17	Ratios - Axle	1, 3, 17
Carburetor	3, 8	Compression	1, 2, 3
Caster	21	Steering	20
Choke, Automatic	8	Transmission	15, 16
Circuit Breakers, Fuses	14	Rear Axle	1, 3, 17
Clearance, Ground	25	Regulator - Generator	10
Clutch - Pedal Operated	15	Rims	18
Coil, Ignition	11	Rings, Piston	4
Connecting Rods	4	Rods - Connecting	4
Cooling System	9	Shock Absorbers, Front & Rear	19
Crankcase Ventilation	7	Spark Plugs	11
Crankshaft	5	Speedometer	12
Cylinders and Cylinder Head	2	Springs - Front & Rear Suspension	20, 21
Dimension Definitions	34, 35, 36	Valve, Engine	6
Distributor - Ignition	11	Stabilizer (Sway Bar) - Front & Rear	20, 21
Electrical System	10, 11, 12, 13, 14	Starting Motor	10
Engine		Steering	20, 21
Bore, Stroke, Displacement, Type	1, 2	Suppression - Ignition, Radio	11
Compression Ratio	1, 2	Suspension - Front & Rear	19, 20, 21
Firing Order, Cylinder Numbering	2, 11	Switches	12
General Information, H.P. & Torque	1, 2	Tailpipe	7
Lubrication	6, 7	Thermostat, Cooling	9
Power Teams	3	Timing, Engine & Valve	5, 6, 11
Exhaust System	7	Tires	1, 18
Fan, Cooling	9	Toe in	21
Filters - Engine Oil, Fuel System	7, 8	Torque Converter	16
Frame	19	Torque - Engine, Rated	1, 2, 3
Front Suspension	19, 20	Transmission - Types	1, 3, 8, 15, 16
Fuel, Fuel Pump, Fuel System	1, 2, 8	Automatic	1, 3, 8, 15, 16
Fuel Injection	1, 8	Manual & Overdrive	1, 3, 8, 15, 16
Fuses, Circuit Breakers	14	Ratios	15, 16
Generator and Regulator	10	Tread	1, 22
Glass	24, 32	Turning Diameter	20
Height (Lamps)	14	Unitized Construction	19
Headroom - Body	26, 27, 30	Universal Joints, Propeller Shaft	16, 17
Heights - Overall	1, 24	Valves - Intake & Exhaust	5, 6
Hood	23	Vibration Damper	5
Horns	12	Voltage Regulator	10
Horsepower - Brake, Taxable	1, 2, 3	Water Pump	9
Ignition System	11	Weights - Shipping, Curb	33
Inflation - Tires	18	Wheel Alignment	21
Instruments	7, 12	Wheelbase	1, 23
Kingpin (Steering Axis)	21	Wheels & Tires	18
		Wheel Spindle	21
		Widths - Car & Body	1, 22
		Windshield	24, 32
		Windshield Wiper	12