

# AMA Specifications—Passenger Car

The information contained herein is prepared, distributed by, and is solely the responsibility of the automobile manufacturing company to whose products it relates. Questions concerning these specifications should be directed to the manufacturer whose address is shown below. This uniform specification form was developed by the automobile manufacturing companies under the auspices of the Automobile Manufacturers Association.

MANUFACTURER Chevrolet Motor Division Owner Relations Department		CAR NAME CHEVY II	
MAILING ADDRESS 1077 Argonaut "A" G.M. Bldg. Detroit, Michigan 48202		MODEL YEAR 1968	ISSUED: 10-15-67 REVISED (e)

**NOTES:**

1. The Specifications herein are those in effect at date of compilation and are subject to change without notice by the manufacturer.
2. UNLESS OTHERWISE INDICATED:
  - a. Specifications apply to standard models without optional equipment. Significant deviations are noted.
  - b. Nominal design dimensions are used throughout these specifications.

### TABLE OF CONTENTS

Car & Body Dimensions . . . . .	1,2	Drive Units . . . . .	14	Suspensions . . . . .	21
Engine - Mechanical . . . . .	4	Brakes . . . . .	18, 19	Weights . . . . .	24
Electrical . . . . .	12	Steering . . . . .	20	Index . . . . .	27

BODY - TYPES AND STYLE NAMES -	Body type, number of passenger & style names; use manufacturer's code for series & body style.		
	153 Cu. In. L4-90 HP <u>Standard</u>	230 Cu. In. L6-140 HP <u>Standard</u>	307 Cu. In. V8-200 HP <u>Standard</u>
NOVA			
2-Door Coupe-5 Passenger	11127	11327	11427
4-Door Sedan-6 Passenger	11169	11369	11469

# AMA Specifications—Passenger Car

MAKE OF CAR CHEVY II MODEL YEAR 1968 DATE ISSUED 10/15/67 REVISED <sup>(a)</sup>

## CAR AND BODY DIMENSIONS

See Pages 25, 26 for SAE Dimension Definitions . . .

(All dimensions in inches unless otherwise indicated)

All dimensions to ground are for comparative purposes only and are shown with vehicle load of two passengers in front and three in rear, except where otherwise noted.

MODEL	SAE Ref. No.	2-Door Coupe (27)	4-Door Sedan (69)
<b>WIDTH</b>			
Track - Front	W101		59.0
Track - Rear	W102		58.9
Maximum overall car width	W103		72.4
Body width at No. 2 pillar	W117		
<b>LENGTH</b>			
Body "O" to front of dash	L 30		
Wheelbase	L101		111.0
Overall car length	L103		189.4
Overhang - front	L104		29.8
Overhang - rear	L105		48.6
Body upper structure length	L123		
Body "O" line to $\text{C}$ of rear wheel	L127		93.0
Body "O" line to w/s cowl point	L130		
<b>HEIGHT</b>			
Overall height	H101		
Cowl height	H114	36.7	37.2
Deck height	H138		
Rocker panel - front	To ground	8.5	8.9
	From front wheel $\text{C}$		
Rocker panel - rear	To ground	8.7	9.1
	From rear wheel $\text{C}$		
Windshield slope angle	H122		
<b>GROUND CLEARANCE</b>			
Bumper to ground - front	H102	12.9	13.4
Bumper to ground - rear	H104	13.5	13.9
Angle of approach	H106	31	32
Angle of departure	H107		18
Ramp breakover angle	H147	14	16
Min. running clearance (Specify)	H156	5.8 (Exhaust system to grd.) 6.3	

## AMA Specifications—Passenger Car

 MAKE OF CAR CHEVY II MODEL YEAR 1968 DATE ISSUED 10/15/67 REVISED (\*)

## CAR AND BODY DIMENSIONS

 See Pages 25, 26 for SAE Dimension Definitions  
 (All dimensions in inches unless otherwise indicated)

MODEL	SAE Ref. No.	2-Door Coupe (27)	4-Door Sedan (69)
-------	--------------	----------------------	----------------------

## FRONT COMPARTMENT

Effective head room	H61	37.6	38.8
Max. eff. leg room — accelerator	L34		41.6
H Point to Heel point	H30		8.4
H Point travel	L17		4.0
Shoulder room	W 3	56.9	56.7
Hip room	W 5	56.2	56.4
Upper body opening to ground	H50		

## REAR COMPARTMENT

H Point couple distance	L50	30.2	32.5
Effective head room	H63	36.6	37.2
Min. effective leg room	L51	32.6	35.3
H Point to Heel point	H31	11.0	12.2
Min. knee room	L48		
Rear Compartment room	L 3	24.4	26.2
Shoulder room	W 4	55.0	56.2
Hip room	W 6	56.3	55.1
Upper body opening to ground	H51	--	50.8

## LUGGAGE COMPARTMENT

Usable luggage capacity	V 1		12.4
Liftover height	H195		23.2
Position of spare tire storage			
Method of holding lid open			

## STATION WAGON — THIRD SEAT

Shoulder Room	W85		
Hip room	W86		NOT
Effective leg room	L86		
Effective head room	H86		AVAILABLE
Seat facing direction			

## STATION WAGON — CARGO SPACE

Cargo length at floor — front seat	L202		
Cargo length at belt — front seat	L204		NOT
Cargo width — wheelbase	W201		
Opening width at belt	W204		AVAILABLE
Maximum cargo height	H201		
Rear opening height	H202		
Cargo volume index (cu. ft.) W4 x L204 x H201 1728	V2		

# AMA Specifications—Passenger Car

MAKE OF CAR CHEVY II MODEL YEAR 1968 DATE ISSUED 10/15/67 REVISED (\*)

## POWER TEAMS

(Indicate whether standard or optional)

MODEL AVAILABILITY	ENGINE					TRANSMISSION	AXLE RATIO ** (Std. first) (Indicate A/C ratio) *				
	Displ. cu. in.	Carburetor	Compr. Ratio	BHP RPM	Torque RPM		A	B	C	D	
All Models	153 Standard	One: 1-bbl down-draft	8.5:1	90 @ 4000	152 @ 2400	3-Speed (2.85:1 low) and Power-glide*	Base	3.08	2.73	3.55	--
							A/C	Not available			
All Models	230 Standard	One: 1-bbl down-draft	8.5:1	140 @ 4400	220 @ 1600	3-Speed (2.85:1 low)	Base	3.08	2.73	3.36	3.55
							A/C	3.08	--	3.55	--
						Power-* glide	Base	2.73	2.56	3.55	--
							A/C	3.08	--	3.55	--
All Models	307 Standard	One: 2-bbl down-draft	9.00:1	200 @ 4600	300 @ 2400	3-Speed (2.54:1 low) and 4-Speed * (2.85:1 low)	Base	3.08	2.73	3.55	--
							A/C	3.08	--	3.55	--
						Power-* glide	Base	2.73	2.56	3.55	--
							A/C	3.08	--	3.55	--
A - Standard B - Economy C - Performance D - Special * - Optional ** - Positraction Axle Ratios Available in combination as shown											

# AMA Specifications—Passenger Car

MAKE OF CAR	CHEVY II	MODEL YEAR	1968
		DATE ISSUED	10/15/67
		REVISED (*)	
MODEL	11100	11300	11400
	153 Cu. In. L-4 (Std.)	230 Cu. In. L-6 (Std.)	307 Cu. In. V-8 (Std.)

## ENGINE – GENERAL

Type, no. cyls., valve arr.	In-line 4 OHV	In-line 6 OHV	90° OHV V-8
Bore and stroke (nominal)	3.85 x 3.25		
Piston displacement, cu. in.	153	230	307
Bore spacing (C to C)	4.40		
No. system (front to rear)	L. Bank	1-2-3-4	1-2-3-4-5-6
	R. Bank	In-line	In-line
Firing order	1-3-4-2	1-5-3-6-2-4	1-3-5-7
Compres. ratio (nominal)	8.5:1		9.00:1
Cylinder Head Material	Cast alloy iron		
Cylinder Block Material	Cast alloy iron		
Cyl. Sleeve-Wet, dry, none	None		
Number of mtg. points	Front	Two	
	Rear	One	
Engine installation angle			
Taxable horsepower <small>Dia<sup>2</sup>xNo. Cyl. 2.5</small>	24.0	36.0	48.0
Publishing max. bhp* @ eng. RPM	90 @ 4000	140 @ 4400	200 @ 4600
Publishing max. torque* (l <sup>b</sup> ft. @ RPM)	152 @ 2400	220 @ 1600	300 @ 2400
Recommended fuel regular – premium	Regular		

## ENGINE – PISTONS

Material	Cast aluminum alloy		
Description and finish	Flat, notched head, slipper skirt		
Weight (piston only) oz.	20.32		26.32
Clearance (limits)	Top land	.0345 - .0435	
	Skirt	Top	.0005 - .0011(a)
		Bottom	.0005 - .0011(b)
Ring groove depth	No. 1 ring	.2153 - .2218	
	No. 2 ring	.2153 - .2218	
	No. 3 ring	.2093 - .2158	
	No. 4 ring	.2053 - .2118	

\* Max. bhp (brake horsepower) and max. torque corrected to 60° F and 29.92 in. Hg atmospheric pressure.

(a) Measured 2.44 from top of piston

(b) Measured 1.675 from top of piston

## AMA Specifications—Passenger Car

MAKE OF CAR CHEVY II MODEL YEAR 1968 DATE ISSUED 10/15/67 REVISED (\*)

	11100	11300	11400
MODEL	153 Cu. In. L-4 (Std.)	230 Cu. In. L-6 (Std.)	307 Cu. In. V-8 (Std)

## ENGINE - RINGS

Function (top to bottom)	No. 1, oil or comp.	Compression	
	No. 2, oil or comp.	Compression	
	No. 3, oil or comp.	Oil	
	No. 4, oil or comp.	None	
Compression	Description - material, coating, etc.	Cast alloy iron; inside bevel, tapered face; barrel face with no bevel on upper ring for 307 Cu. In. V-8. Flash chrome plate-upper; Wear resistant coating-lower.	
	Width	(a)	(b)
	Gap	.010 - .020	
Oil	Description - material, coating, etc.	Multi-piece (2 rails and 1 spacer expander) Rails-steel, chrome plated OD; Expander-Stainless Steel	
	Width	.1870 - .1890 (assembled)	
	Gap	.015 - .055	
Expanders	In oil ring assembly		

## ENGINE - PISTON PINS

Material	Chromium steel		
Length	2.990 - 3.010		
Diameter	.9270 - .9273		
Type	Locked in rod, in piston, floating, etc.	Locked in rod	
	Bush- ing	In rod or piston	None
		Material	--
Clearance	In piston	.00015 - .00025	
	In rod	None	
Direction & amount offset in piston	Major thrust side .060		

## ENGINE - CONNECTING RODS

Material	Drop forged steel	
Weight (oz.)	12.50	20.80
Length (center to center)	5.695 - 5.705	
Bearing	Material & Type	Copper lead alloy or sintered copper nickel backed babbitt on steel
	Overall length	.807
	Clearance (limits)	.0007 - .0027
	End play	.009 - .013

(a) - Upper .0775 - .0780; lower .0770 - .0780

(b) - Upper .0775 - .0780; lower .0775 - .0780

## AMA Specifications—Passenger Car

MAKE OF CAR	CHEVY II	MODEL YEAR	1968	DATE ISSUED	10/15/67	REVISED (*)
	11100		11300		11400	
MODEL	153 Cu. In. L-4 (Std.)	230 Cu. In. L-6 (Std.)	307 Cu. In. V-8 (Std.)			

## ENGINE - CRANKSHAFT

Material	Cast nodular iron				
Vibration damper type	Rubber mounted inertia				
End thrust taken by bearing (No.)	7		5		
Crankshaft end play	.002 - .006				
Main bearing	Material & type	Steel with backed insert (selected bearing material-copper lead alloy or premium aluminum-for intended operation or application)			
	Clearance	.0003 - .0029 (a)			
	Journal dia. and bearing overall length	No. 1	2.3004 x .752	2.4503 x .752	
		No. 2	2.3004 x .752	2.4505 x .752	
		No. 3	2.3004 x .752	2.4505 x .752	
		No. 4	2.3004 x .752	2.4505 x .752	
		No. 5	2.3004 x .760	2.3004 x .752	2.4507 x 1.177
		No. 6	None	2.3004 x .752	None
No. 7		None	2.3004 x .760	None	
Dir. & amt. cyl. offset	None				
Crankpin journal diameter	1.999 - 2.000		2.099 - 2.100		

## ENGINE - CAMSHAFT

Location	Above and to right of crankshaft	In block above crn/shft		
Material	Cast alloy iron			
Bearings	Material	Steel backed babbitt		
	Number	4	5	
Type of Drive	Gear or chain	Gear	Chain	
	Crankshaft gear or sprocket material	Steel	Steel sprocket	
	Camshaft gear or sprocket material	Bakelite and fabric composite with steel hub	Cast alloy iron	
	Timing chain	No. of links	None	46
		Width	None	.740
Pitch		None	.500	

## ENGINE - VALVE SYSTEM

Hydraulic lifters (Std., opt., NA)	Standard	
Valve rotator, type (intake, exhaust)	None	
Rocker ratio	1.75:1	1.50:1
Operating tappet clearance (indicate hot or cold)	Intake	Zero
	Exhaust	Zero

(Continued)

- (a) No 1 .0008 - .0020  
 No 2, 3 & 4 .0008 - .0024  
 No 5 .0015 - .0031

# AMA Specifications—Passenger Car

MAKE OF CAR	CHEVY II	MODEL YEAR	1968	DATE ISSUED	10/15/67	REVISED (*)	
			11100		11300		11400
MODEL			153 Cu. In. L-4 (Std.)		230 Cu. In. L-6 (Std.)		307 Cu. In. V-8 (Std.)

## ENGINE - VALVE SYSTEM (cont.)

			11100	11300	11400
Timing (based on top of ramp points)	Intake	Opens (°BTC)	17° 30'	16°	28°
		Closes (°ABC)	54° 30'	48°	72°
		Duration - deg.	252°	244°	280°
	Exhaust	Opens (°BBC)	57°	46° 30'	78°
		Closes (°ATC)	15°	17° 30'	30°
		Duration - deg.	252°	244°	288°
Valve opening overlap			32° 30'	33° 30'	58°
Intake	Material		Alloy steel		
	Overall length		4.902 - 4.922		
	Actual overall head dia.		1.715 - 1.725		
	Angle of seat & face		46° (seat) 45° (face)		
	Seat insert material		None		
	Stem diameter		.3410 - .3417		
	Stem to guide clearance		.0010 - .0027		
	Lift (@ zero lash)		.3973	.3317	.3900
	Outer spring press. & length	Valve closed (lb.@in.)	78-86 @ 1.66	56-64 @ 1.66	76-84 @ 1.70
		Valve open (lb.@in.)	170-180 @ 1.26	180-192 @ 1.27	194-206 @ 1.25
	Inner spring press. & length	Valve closed (lb.@in.)	None		Spring damper
		Valve open (lb.@in.)	None		Spring damper
Exhaust	Material		High alloy steel - aluminized face on 307 cu. in.		
	Overall length		4.913-4.933		
	Actual overall head dia.		1.495-1.505		
	Angle of seat & face		46° (seat) 45° (face)		
	Seat insert material		None		
	Stem diameter		.3410 - .3417		
	Stem to guide clearance		.0017 - .0027		
	Lift (@ zero lash)		.3973	.3317	.4100
	Outer spring press. & length	Valve closed (lb.@in.)	78-86 @ 1.66	56-64 @ 1.66	76-84 @ 1.70
		Valve open (lb.@in.)	170-180 @ 1.26	180-192 @ 1.27	194-206 @ 1.25
	Inner spring press. & length	Valve closed (lb.@in.)	None		Spring damper
		Valve open (lb.@in.)	None		Spring damper

## ENGINE - LUBRICATION SYSTEM

Type of lubrication (splash, pressure, nozzle)			
Main bearings		Pressure	
Connecting rods		Pressure	
Piston pins		Splash	
Camshaft bearings		Pressure	
Tappets		Pressure	
Timing gear or chain		Nozzle	(a)
Cylinder walls		Splash	Press. jet cross sprayed

(Continued)

(a) Centrifugally oiled from camshaft bearing

# AMA Specifications—Passenger Car

MAKE OF CAR	CHEVY II	MODEL YEAR	1968
		DATE ISSUED	10/15/67
		REVISED (e)	
MODEL	11100	11300	11400
	153 Cu. In. L-4 (Std.)	230 Cu. In. L-6 (Std.)	307 Cu. In. V-8 (Std.)

## ENGINE – LUBRICATION SYSTEM (cont.)

Oil pump type	Gear
Normal oil pressure (lb. engine rpm)	50-65 PSI @ 2000 RPM (bench test—no flow conditions)
Oil press. sending unit (elect. or mech.)	Electric
Type oil intake (floating, stationary)	Stationary
Oil filter system (full flow, part., other)	Full flow
Filter replacement (element, complete)	Complete
Capacity of c./case, less filter-refill (qt.)	4
Oil grade recommended (SAE viscosity and temperature range)	32° and above - SAE 20W or SAE 10W-30 0° F to 32° F* - SAE 10W or SAE 10W-30 Below 0° F - SAE 5W or SAE 5W-20 *(SAE 5W-30 can be used at temperatures below freezing)
Engine Service Reamt. (MM, MS, etc.)	

## ENGINE – EXHAUST SYSTEM

Type (single, single with cross-over, dual, other)	Single	Single with crossover
Muffler No. & type (reverse flow, straight thru, separate resonator)	One, reverse flow	
Exhaust pipe dia. (O.D. wall thick.)	Branch	None
	Main	2.00 x .057-.071
Tail pipe dia. (O.D. & wall thickness)	1.875 x .062-.076	

## ENGINE – CRANKCASE VENTILATION SYSTEM

Type (ventilates to atmos., induction system, other)	Standard	Ventilates to induction system
	Optional	None
Control Unit	Make and model	AC Spark Plug 153 (6424189); 230 (6424191); 307 (6424251)
	Location	Rear of rocker cover   L ft. frnt. of rocker covr.
	Energy source (manifold vacuum, carburetor air stream, other)	Manifold vacuum
	Control method (variable orifice, fixed orifice, other)	Variable orifice
Complete system	Discharges (to intake manifold, carb. air intake, air cleaner intake, other)	Intake manifold
	Air inlet (breather cap, carburetor air cleaner, other)	Carburetor air cleaner
	Flame arrestor (screen, check valve, other)	Screen

(a) Laminated

## AMA Specifications—Passenger Car

MAKE OF CAR CHEVY II MODEL YEAR 1968 DATE ISSUED 10/15/67 REVISED (\*)

	153 Cu. In.		230 Cu. In.		307 Cu. In.	
MODEL	Manual	Auto	Manual	Auto	Manual	Auto

## ENGINE - EXHAUST EMISSION CONTROL

Type (Air injection, engine modifications, other)		MANUAL TRANS. - Air injection reactor equipment AUTOMATIC TRANS. - Controlled combustion system						
Air Injection Pump	Type	Semi-articulated vane type						
	Displacement	19.3						
	Drive ratio							
	Drive type	Crankshaft pulley						
	Relief valve (type)	Diverter valve separate from pump						
	Filter (describe)	Centrifugal air cleaner						
Air Injection System	Air distribution (head, manifold, etc.)	Head			Manifold			
	Point of entry	Exhaust ports						
	Injection tube I.D.	.2565						
	Check valve type	Pressure (plate & type)						
	Backfire protection (type)	Diverter valve						
Carburetor	Make	Rochester						
	Model	7028009	7028008	7028017	7028014	7028101	7028101	
	Barrel size	1.69		1.69		1.44		
	Idle speed	Drive	---	600	---	500	---	600
		Neutral	750	---	700	---	700	---
	Idle A/F mixture	Not specified						
Aux. Adv. Systems (type)	None							
Distributor	Make	Delco-Remy						
	Model	1110447	1110426	1110436	1110433	1111257		
	Cent'fgal adv. in crank degrees @ eng. rpm	Start (rpm)	900		1000		900	
		Intermed. points deg. @ rpm	17@1700	14@1700	21@2100	17@2100	10@1600	
		Max. deg. @ rpm	28@3700	24@3600	36@4600	32@4600	28@4300	
	Vacuum adv. in crank degrees @ eng. rpm	Start (in Hg)	7.00		7.00		6.00	
		Intermed. points deg. @ in. Hg	None					
		Max. deg. @ in.	24 @ 15		23 @ 16		15 @ 12	
	Vacuum Source	Carburetor						
	Timing - Crank degrees @ rpm (a)	TDC	4BTC	TDC	4BTC	2BTC		
Cooling System (describe changes)	None							
Exhaust System (describe changes)	None							

\* Used with manual transmissions only;

(a) At idle

## AMA Specifications—Passenger Car

MAKE OF CAR CHEVY II MODEL YEAR 1968 DATE ISSUED 10/15/67 REVISED <sup>(\*)</sup>  
 MODEL 11100 11300 11400  
153 Cu. In. L-4 (Std.) 230 Cu. In. L-6 (Std.) 307 Cu. In. V-8 (Std.)

## ENGINE—FUEL SYSTEM

(See supplemental page for Details of Fuel Injection, Supercharger, etc. if used)

Induction type: Carburetor, fuel injection, supercharger.		Carburetor		
Fuel Tank	Refill capacity (U.S. gals.)	18 (approximately)		
Fuel Tank	Filler location	Behind hinged rear license plate		
Fuel Pump	Type (elec. or mech.)	Mechanical		
Fuel Pump	Locations	Lower right front of engine		
Fuel Pump	Pressure range	3.50-4.50 PSI	5.00-6.50 PSI	
Vacuum booster (std., optional, none)		None		
Fuel Filter	Type	Five mesh plastic strainer in gasoline tank and		
Fuel Filter	Locations	paper filler in carburetor inlet		
Carburetor	Choke type	Automatic		
	Intake manifold heat control (exhaust or water)	Exhaust		
	Air cleaner type	Standard	Oil-wetted paper	
		Optional	None	
	Idle speed (spec. neutral or drive)	Manual	750 (neutral)	700 (neutral)
Automatic		600 (drive)	500 (drive) 600 (drive)	
Idle A/F mix.		Not specified		

## CARBURETOR SUPPLEMENTARY INFORMATION

Model Usage	Engine Displ.	Transmission	Carburetors		No. Used and Type	Barrel Size
			Make	Model		
11100	153	3-Speed	Rochester	7028009	One; Single barrel down-draft	1.69
		Powerglide	Rochester	7028008		
11300	230	3-Speed	Rochester	7028017 (a)	One; 2-bbl down-draft	1.44
		Powerglide	Rochester	7028014		
11400	307	3-Speed & 4-Speed	Rochester	7028101 (b)	One; 2-bbl down-draft	1.44
		Powerglide	Rochester	7028110 (c)		
(a) 7028015 with Air Conditioning						
(b) 7028103 with Air Conditioning						
(c) 7028112 with Air Conditioning						

# AMA Specifications—Passenger Car

MAKE OF CAR	CHEVY II	MODEL YEAR	1968
		DATE ISSUED	10/15/67
		REVISED	(*)
MODEL	11100	11300	11400
	153 Cu. In. L-4 (Std.)	230 Cu. In. L-6 (Std.)	307 Cu. In. V-8 (Std.)

### ENGINE - COOLING SYSTEM

Type system (pressure, pressure vented, atmospheric, other)		Pressure		
Radiator cap relief valve pressure		15 ± 1 PSI		
Circulation thermostat	Type (choke, bypass)	Choke		
	Starts to open at (°F)	192° - 198°		
Water pump	Type (centrifugal, other)	Centrifugal		
	GPM @ 1000 pump rpm	60 @ 4400	54 @ 4400	
	Number of pumps	One		
	Drive (V-belt, other)	V-belt		
	Bearing type	Permanently lubricated double row ball		
By-pass recirculation type (inter., ext.)		Internal		
Radiator core type (cellular, tube and fin, other)		Tube and center		
Cooling system capacity	With heater (qt.)	9	12	17
	Without heater (qt.)	8	11	16
	Opt. equipment-specify (qt.)	9	12	17
Water jackets full length of cyl. (yes, no)		Yes		
Water all around cylinder (yes, no)		Yes		
Radiator hose	Lower	Number and type (molded, straight)	One, molded	
		Inside diameter	1.75	
	Upper	Number and type (molded, straight)	One, molded	
		Inside diameter	1.50	
	By-pass	Number and type (molded, straight)	None	
		Inside diameter	None	
Fan	Number of blades & spacing		4-Staggered	
	Diameter		16.00	17.62
	Ratio-fan to crankshaft rev.		.949:1	
	Fan cutout type		None	
	Bearing type		Double row ball	
* Drive belts (indicate belt used by letter)	Fan	A	C	G
	Generator or alternator	A	C	G
	Water Pump	A	C	G
	Power Steering	--	D	H
	Air Conditioning	--	E	I
		B	F	J

* Drive Belt Dimensions	A	B	C	D	E	F	G	H	I	J	K
Angle of V	←				38°-42°	→					
Nominal length (SAE)	41.00	50.00	39.00	50.00	54.75	50.00	53.50	35.00	57.50	49.50	
Width	←				.380	→					

# AMA Specifications—Passenger Car

MAKE OF CAR	CHEVY II	MODEL YEAR	1968	DATE ISSUED	10/15/67	REVISED (a)
MODEL	11100	11300	11400	153 Cu. In. L-4 (Std.)	230 Cu. In. L-6 (Std.)	307 Cu. In. V-8 (Std.)

### ELECTRICAL – SUPPLY SYSTEM

Battery	Make and Model		Delco-Remy 1980032				
	Voltage Rtg. & Total Plates		12 volts - 54 plates				
	SAE Designation & Amp. Hr. Rtg.		45 amp. hr @ 20 hr. rate				
	Location		Right side of engine compartment				
	Terminal grounded		Negative				
Generator or Alternator	Make		Delco-Remy				
	Model		1100813		1100794		
	Type and rating		Diode rectified-37 amps				
	Output at engine idle (neutral)		13 amps				
	Ratio-Gen. to Cr/s rev.		2.46:1				
Regulator	Make		Delco-Remy				
	Model		1119515				
	Type		Vibrator				
	Cutout relay	Closing voltage generator rpm		None			
		Reverse current to open		None			
	Regulated	Voltage		13.8-14.8 @ 85° F			
		Current		- - -			
	Voltage test conditions	Temperature		Operating			
Load		3-8 amperes					
	Other		None				

### ELECTRICAL – STARTING SYSTEM

Starting Motor	Make		Delco-Remy				
	Model		1108365		1108367		
	Rotation (drive end view)		Clockwise				
Motor control	Switch (solenoid, manual)		Solenoid				
	Starting procedure		3-Spd & 4-Spd-Place gearshift lever in neutral and depress clutch AUTOMATIC-Place gearshift lever in N or P position INITIAL START-Press accelerator to floor and release. (a) Turn ignition to START, release as soon as engine starts.				
	Engagement type		Positive shift solenoid				
Motor Drive	Pinion meshes (front, rear)		Rear				
	Number of teeth	Pinion		9			
		Flywheel	Manual		153		
			Auto.		153		
	Flywheel tooth face width	Manual		.4010 - .4130			
Auto.		.4010 - .4130					

(a) On 153 Cu. In. -Pull hand choke knob fully out.

## AMA Specifications—Passenger Car

MAKE OF CAR		CHEVY II	MODEL YEAR		1968	DATE ISSUED		10/15/67	REVISED (*)		
MODEL		11100	11300	11400		153 Cu. In. L-4 (Std.)		230 Cu. In. L-6 (Std.)	307 Cu. In. V-8 (St		
ELECTRICAL – IGNITION SYSTEM		Manual	Auto	Manual	Auto	Manual	Auto				
Type	Conventional – Std., Opt., N.A.	Standard									
	Transistorized – Std., Opt., N.A.	N.A.									
	Other (specify)	None									
Coil	Make	Delco-Remy									
	Model	1115208						1115293			
	Amps	Engine stopped	4.0								
		Engine idling	1.8								
Distributor	Make	Delco-Remy									
	Model	1110447	1110426	1110436	1110433	1111257					
	Cent'fgal adv. in c/shaft degrees@ engine rpm (nominal)	Start (rpm)	900			1000			900		
		Intermediate points deg.@rpm	17@1700	14@1700	21@2100	17@2100	10@1600				
		Max. deg.@rpm	28@3700	24@3600	36@4600	32@4600	28@4300				
	Vacuum adv. in c/shaft degrees@ in. Hg. (nominal)	Start (in. Hg.)	7.00			7.00			6.00		
		Intermediate points, deg.@in. Hg.	None								
		Max. deg. in. Hg.	24 @ 15			23 @ 16			15 @ 12		
	Breaker gap (in.)	.019									
	Cam angle (deg.)	31-34						28-32			
Breaker arm tension (oz.)	19-23										
Timing	Crankshaft deg.@rpm (a)	TDC	4BTC	TDC	4BTC	2BTC					
	Mark location	Torsional damper									
Spark Plug	Make	AC Spark Plug									
	Model	AC 46 N (long reach)						AC45S			
	Thread (mm)	14									
	Tightening torque (lb. ft.)	25									
	Gap	.033 - .038									
Cable	Conductor type	Linen core impregnated with electrical conducting material									
	Insulation type	Rubber with neoprene									
	Spark plug protector	Neoprene									

## ELECTRICAL – SUPPRESSION

Locations & type	Non-metallic high ignition cables
------------------	-----------------------------------

(a) At idle

# AMA Specifications—Passenger Car

MAKE OF CAR	CHEVY II	MODEL YEAR	1968	DATE ISSUED	10/15/67	REVISED (a)
MODEL	11100	11300	11400	153 Cu. In. L-4 (Std.)	230 Cu. In. L-6 (Std.)	307 Cu. In. V-8 (Std.)

## ELECTRICAL – INSTRUMENTS AND EQUIPMENT

Speed-ometer	Type	Dial
	Trip odometer (yes,no)	N. A.
Charge indicator – type		Tell-tale
Temperature indicator – type		Tell-tale
Oil pressure indicator – type		Tell-tale
Fuel indicator – type		Electric gauge
Other		Refer to page 23
Wind-shield wiper	Type – Standard	Electric two-speed
	Type – Optional	None
Wind-shield washer	Type – Standard	Push-button
	Type – Optional	None
Horn	Type	Vibrator
	Number used	One
	Amp draw (each)	(Low note) 4.5-6 @ 12.5V.

## DRIVE UNITS – CLUTCH (Manual Transmission)

Make & type	3-Speed	3-Spd H.D.	3-Speed	3-Spd H.D.	3-Speed	4-Speed
Type pressure plate springs	Chevrolet-Single dry disc					(a)
Tc spring load (lb.)	1350-1450	1900-2200	1650-1850	1900-2200	1900-2200	2100-2300
No. clutch driven discs	One					
Clutch facing	<i>Material</i> Woven asbestos (molded asbestos on rear facing of H.D. clutch)					
	Outside & inside dia.	9.12 & 6.12	10.0 & 6.0	9.12 & 6.12	10.0 & 6.0	10.0 & 6.5
	Total eff. area (sq.in.)	71.8	100.5	71.8	100.5	90.7
	Thickness	.135 each				
Engagement cushioning method	Flat spring steel between facings					
Release bearing	Type & method of lubrication Single row ball, packed and sealed					
Torsional damping	Methods: springs, friction material Coil springs					

- (a) Single dry disc, semi-centrifugal  
 (b) Diaphragm - bent finger design

# AMA Specifications—Passenger Car

<b>MAKE OF CAR</b> <u>CHEVY II</u>	<b>MODEL YEAR</b> <u>1968</u>	<b>DATE ISSUED</b> <u>10/15/67</u> <b>REVISED</b> (*)	
<b>MODEL</b>	11100	11300	11400
	153 Cu. In. L-4 (Std.)	230 Cu. In. L-6 (Std.)	307 Cu. In. V-8 (Std.)

**DRIVE UNITS – TRANSMISSIONS**

Manual 3-speed (std. or opt.)	Standard
Manual 4-speed (std. or opt.)	Not available      Optional
Manual with overdrive (std. or opt.)	Not available
Automatic (std. or opt.)	Powerglide-optional

**DRIVE UNITS – MANUAL TRANS.**

		3-Speed		3-Speed	4-Speed
		3	3	3	4
Transmission ratios	In first	2.85:1	2.85:1	2.54:1	2.85:1
	In second	1.68:1	1.68:1	1.50:1	2.02:1
	In third	1.00:1	1.00:1	1.00:1	1.35:1
	In fourth	--	--	--	1.00:1
	In reverse	2.95:1	2.95:1	2.63:1	2.85:1
Synchronous meshing, specify gears		All forward gears			
Shift lever location		Steering column			Floor
Lubricant	Capacity (pt.)	3			
	Type recommended	Meeting Military Spec. MIL-L-2105-B			
	SAE viscosity number	SAE 80			
	SAE viscosity number	SAE 80			
SAE viscosity number	Summer	SAE 80			
SAE viscosity number	Winter	SAE 80			
SAE viscosity number	Extreme cold	SAE 80			

**DRIVE UNITS – MANUAL TRANS. W/OVERDRIVE**

(For transmission data see manual transmission section)

Type (planetary or other)			
Manual lockout (yes, no)			
Downshift accelerator control (yes, no)			
Minimum cut-in speed		NOT	
Gear ratio			
Lubricant	Capacity (pt.) (Overdrive only)	AVAILABLE	
	Separate filler (yes, no)		
	Type recommended		
	SAE viscosity number	Summer	
	SAE viscosity number	Winter	
SAE viscosity number	Extreme cold		

# AMA Specifications—Passenger Car

MAKE OF CAR CHEVY II MODEL YEAR 1968 DATE ISSUED 10/15/67 REVISED <sup>(\*)</sup>

	11100	11300	11400
MODEL	153 Cu. In. L-4(Std.)	230 Cu. In. L-6(Std.)	307 Cu. In. V-8(Std.)

## DRIVE UNITS – AUTOMATIC TRANSMISSION

Trade name	Powerglide		
Type describe	Torque converter with planetary gears		
Selector location	Steering column; floor mounted when used with floor console on coupes with bucket seats		
List gear ratios Selector Pattern and indicate which are used in each selector position	P - Park R - Reverse N - Neutral D - 1.82-1.00 L - 1.82		
Max. upshift speed—drive range	54	63	68
Max. kickdown speed—drive range	50	58	65
	Number of elements 3		
Torque converter	Max. ratio at stall	2.40	2.10
	Type of cooling (air, liquid)	Air	Water
	Nominal diameter	11.00	11.75
Lubricant	Capacity—refill (pt.)	6	
	Type recommended	A suffix A	
Special transmission features			

## DRIVE UNITS – PROPELLER SHAFT

Number used	One			
Type (straight tube, tube-in-tube, internal-external damper, etc.)	Straight tube			
Outer diam. x length* x wall thickness	Manual 3-speed trans.	2.75 x 53.00 x .065		
	Manual 4-speed trans.	Same as 3-Speed		
	Overdrive transmission	NA		
	Automatic transmission	Same as 3-Speed		

\* Center to center of universal joints, or to centerline of rear attachment.

(Continued)

# AMA Specifications—Passenger Car

MAKE OF CAR CHEVY II MODEL YEAR 1968 DATE ISSUED 10/15/67 REVISED (\*)  
 MODEL 11100 11300 11400  
153 Cu. In. L-4 (Std.) 230 Cu. In. L-6 (Std.) 307 Cu. In. V-8 (Std.)

### DRIVE UNITS – PROPELLER SHAFT (cont.)

Intermediate bearing	Type (plain, anti-friction)	None
	Lubrication (fitting, prepack)	- - -
Slip Yoke	Type	Yoke
	Number of teeth	27
	Spline O.D.	1.502 - 1.503
Universal joints	Make and Mfg. No.	Chevrolet 3841935
	Number used	Two
	Type (ball and trunnion, cross)	Cross
	Rear attach. (u-bolt, clamp, etc.)	U-bolt
	Bearing	Type (plain, anti-friction)
Lubric. (fitting, prepack)		Prepack
Drive taken through (torque tube or arms, springs)		Leaf spring
Torque taken through (torque tube or arms, springs)		Leaf spring

### DRIVE UNITS – AXLE

Type (front, rear)	Rear		
Description	Semi-floating, overhung pinion gear		
Limited Slip differential, type	Dual disc clutches		
Drive Pinion Offset	1.50		
No. of differential pinions	Two		
Pinion adjustment (shim, other)	None		
Pinion bearing adj. (shim, other)	Shim		
Wheel bearing type	Single row cylindrical roller		
Lubricant	Capacity (pt.)	3.5	
	Type recommended	Meeting Military Specs. MIL-L-2105-B	
	SAE viscosity number	Summer	SAE 80
		Winter	SAE 80
		Extreme cold	SAE 80

### AXLE RATIO TOOTH COMBINATIONS

(See page 3 for axle ratio usage)

Axle ratio	2.73:1	3.08:1	3.36:1	3.55:1
No. of teeth	Pinion	15	12	11
	Ring gear	41	37	37
Ring Gear O.D.	8.125			

## AMA Specifications—Passenger Car

M/ OF CAR CHEVY II MODEL YEAR 1968 DATE ISSUED 10/15/67 REVISED (\*)  
 MODEL 11100 11300 11400  
153 Cu. In. L-4 (Spd.) 230 Cu. In. L-6 (Spd.) 307 Cu. In. V-8 (Std.)

## DRIVE UNITS – WHEELS

Type & material		Short spoke disc, steel	
Rim (size & flange type)	Std.	14 x 5J	
	Opt.	None	
Attachment	Type (bolt or stud)	Stud	
	Circle diameter	4.75	
	Number and size	5 hex nuts, 7/16-20 UNF-2B	

MODEL \_\_\_\_\_

## DRIVE UNITS – TIRES

Standard	Size, ply rating, & ply		7.35 x 14 - 2 ply (4ply rating)	
	Type (bias, radial, etc.)		Bias	
	Full rated Inflation Press.	Front	24 (L-4 & L-6 & V-8 engines)	
		Rear	28 (L-4 & L-6 & V-8 engines)	
	Rev./Mile at 50 MPH		816	
Optional	Size, ply rating, & ply		None	

## BRAKES – PARKING

Type of control		Foot pedal apply; "T" handle release	
Location of control		Left of steering column under instrument panel	
Operates on		Rear service brakes	
If separate from serv brakes	Type (internal or external)	--	
	Drum diameter	--	
	Lining size (length x width x thickness)	--	

# AMA Specifications—Passenger Car

MAKE OF CAR		CHEVY II		MODEL YEAR	1968	DATE ISSUED	10/15/67	REVISED (a)		
MODEL				11100	11300	11400				
				153 Cu. In. L-4 (Spd.)	230 Cu. In. L-6 (Spd.)	307 Cu. In. V-8 (Std.)				
<b>BRAKES – SERVICE</b>				STANDARD		FRONT DISC (OPT) (a)				
Type (drum or disc)				Drum		Disc				
Self adjusting (std., opt., N.A.)						Standard				
Power brake make & type (remote, int., etc.)		Std.								
		Opt.	(b) Bendix: Delco-Moraine vacuum power unit: integral							
Effective area (sq. in.)*				168.9		114.0				
Gross lining area (sq. in.)**				168.9		118.1				
Swept area (sq. in.)***				268.6		332.4				
Percent brake effectiveness – front				59.4		58.5				
Drum or Disc	Diameter (nominal)	Front	9.5		11.0					
		Rear	9.5		9.5					
Drum or Disc	Type and material		Composite, Cast iron; steel web			Cast iron				
	Disc (vented or solid)		- - -			Vented				
	No. pistons per caliper		- - -			4				
Wheel cylinder bore	Front		1.125		2.0625					
	Rear		.875		.875					
Master Cylinder	Bore		.47 Cu. In. @ 0 PSI			.65 Cu. In. @ 0 PSI				
	displacement distribution	Front	%		.33 Cu. In. @ 0 PSI					
		Rear	%		.29 Cu. In. @ 0 PSI					
Disc Brk. Valve	Type (proportion, delay, metering, other)		Check valve							
Pedal arc ratio										
Line pressure at 100 lb. pedal load				790		- - -				
Shoe clearance adjustment						Self adjusting				
Brake lining	Drum or Disc		Drum			Disc				
	Bonded or riveted		Bonded			Riveted				
	Front Wheel	Material		Molded asbestos						
		Size (length x width x thickness)	Prim. or out-board	9.01 x 2.5 x .17			5.96 x 2.21 x .41			
			Second. or in-board	9.75 x 2.5 x .20			5.96 x 2.21 x .41			
		Segments per shoe		One						
	Rear Wheel	Material		Molded asbestos						
		Size (length x width x thickness)	Prim. or out-board	9.01 x 2.0 x .17			9.01 x 2.00 x .17			
Second. or in-board			9.75 x 2.0 x .20			9.75 x 2.00 x .20				
Segments per shoe		One								

\* Excludes rivet holes, grooves, chamfers, etc. \*\* Includes rivet holes, grooves, chamfers, etc.  
 \*\*\* Total swept area for four brakes. (Widest lining contact width for each brake x its contact circumference.)

(a) & (b) Not available with 11100 models (L-4 - 153 engine)

## AMA Specifications—Passenger Car

MAKE OF CAR	CHEVY II	MODEL YEAR	1968	DATE ISSUED	10/15/67	REVISED (e)
MODEL	11100	11300	11400	153 Cu.In.L-4 (Std.)	230 Cu.In.L-6 (Std.)	307 Cu.In.V-8 (Std.)

## STEERING

Manual (std., opt., NA)		Standard-energy absorbing steering column			
Power (std., opt., NA)		Optional with 11300 & 11400 models only			
Adjustable steering wheel (tilt, swing, other)	Type and description	Not available			
	(std., opt., NA)	--			
Wheel diameter	Manual	16.5			
	Power	16.5			
Turning diameter (feet)	Outside front	Wall to wall (l. & r.)			
		Curb to curb (l. & r.)			
	Inside rear	Wall to wall (l. & r.)			
		Curb to curb (l. & r.)			
Outside whl. angle with inside whl. at 20°					
Manual	Gear	Type	Semi-reversible, recirculating ball nut		
		Make	Saginaw		
		Ratios	Gear	24:1	
			Overall	28.3:1	
	No. wheel turns	4.8			
Power	Type (coaxial, linkage, etc.)		Linkage		
	Make		Saginaw		
	Gear	Type	Same as manual		
		Ratios	Gear	17.5:1	
			Overall	20.7:1	
	Pump driven by		Crankshaft pulley		
Number wheel turns		3.5			
Linkage	Type		Parallelogram		
	Location (front or rear of wheels, other)		Rear		
	Drag link (trans. or longit.)		None		
	Tie rods (one or two)		Two		
Steering Axis	Inclination at camber (deg.)		8-1/4 to 9-1/4		
	Bearings (type)	Upper	Ball stud with non-metallic bearings		
		Lower	Ball stud with non-metallic and sintered iron bearings		
		Thrust	None		
Whl. Align. (range at curb wt. & preferred)	Caster (deg.)		0 to P1		
	Camber (deg.)		N-1/4 to P-3/4		
	Toe-in (outside track inches)		1/8 to 1/4		
Steering spindle & joint type		Steering knuckle with spherical joints			
Wheel Spindle	Diameter	Inner bearing	1.2493-1.2498		
		Outer bearing	.7492-.7497		
	Thread size		3/4-20 NEF-3 (modified)		
	Bearing type		Taper roller		

## AMA Specifications—Passenger Car

MAKE OF CAR	CHEVY II	MODEL YEAR	1968	DATE ISSUED	10/15/67	REVISED	(*)
MODEL		11100	11300	11400			
		153 Cu. In. L-4 (Std.)	230 Cu. In. L-6 (Std.)	307 Cu. In. V-8 (Std.)			

## SUSPENSION — GENERAL

(See Supplement page for details on Air Suspension)

Provision for car leveling	Front stabilizer bar with 11400 models only	
Provision for brake dip control	Front suspension geometry	
Provision for acc. squat control	Rear suspension geometry	
Special provisions for car jacking		
Shock absorber front & rear	Type	Direct, double acting, hydraulic
	Make	Delco
	Piston dia.	1.00
Other special features		

## SUSPENSION — FRONT

Type and description	Independent SLA type with coil spring and concentric shock absorber and spherically jointed steering knuckle for each wheel.			
Spring	Type	Coil right hand helix		
	Material	Steel alloy		
	Size (coil design height & I.D. bar length x dia.)	11.09 x 3.63 94.77 x .595	11.09 x 3.63 95.01 x .577	11.09 x 3.63 108.55 x .591
	Spring rate (lb. per in.)	320	345	320
	Rate at wheel (lb. per in.)			
Stabilizer	Type (link, linkless, frameless)	Link		
	Material & bar diameter	Steel .687		

## SUSPENSION — REAR

Type and description	Salisbury rear axle with two single leaf springs		
Drive and torque taken through	Leaf springs		
Spring	Type	Single leaf	
	Material	Chrome carbon steel	
	Size (length x width, coil design height & I.D., bar length & dia.)	56.00 x 2.25 (width C/L of axle)	
	Spring rate (lb. per in.)	115	115
	Rate at wheel (lb. per in.)	121	121
	Mounting insulation type	Rubber bushed at shackle and hanger	
	If leaf	No. of leaves	One
Stabilizer	Shackle (comp. or tens.)	Compression	
	Type (link, linkless, frameless)	None	
	Material	--	
Track bar type	None		

# AMA Specifications—Passenger Car

**MAKE OF CAR** CHEVY II      **MODEL YEAR** 1968      **DATE ISSUED** 10/15/67      **REVISED** (\*)  
**MODEL**      11100      11300      11400  
                  153 Cu. In. L-4 (Std.)      230 Cu. In. L-6 (Std.)      307 Cu. In. V-8 (Std.)

**FRAME**

Type and description (Separate frame, unitized frame, partially - unitized frame)	Combination body-frame integral with separate forward ladder frame
---	--

**BODY – MISCELLANEOUS INFORMATION**

		Coupe	Sedan
Drs. hinged (front, tr.)	Front doors	Front	
	Rear doors	--	Front
Type of finish (lacquer, enamel, other)		Acrylic Lacquer	
Hood counterbalanced (yes, no)		Yes	
Hood release control (internal, external)		External	
Vehicle Ident. No. location		Plate above lower hinge on LH front hinge pillar	
Engine No. location		Right side of cylinder block to rear of distributor	
Theft protection - type		Shielded ignition lock terminals key removable in "OFF" position	
Vent window control method (crank, friction pivot)	Front	Friction pivot	
	Rear	None	
Seat cushion type	Front	Formed wire and foam pad	
	Rear	Formed wire and cotton	
	3rd seat	None	
Seat back type	Front	Formed wire and cotton	
	Rear	Formed wire and cotton	
	3rd seat	None	
Windshield glass type (i.e., single curved - laminated plate)		Curved-laminated plate	
Side glass type (i.e., curved - tempered plate)		Curved-tempered plate	
Backlight glass type (i.e., compound curved - tempered plate, three piece)		Curved-tempered plate	
Windshield glass exposed surface area		1050.8	1111.9
Side glass exposed surface area		1187.2	1242.6
Backlight glass exposed surface area		1144.2	1005.7
Total glass exposed surface area		3382.2	3360.2



# AMA Specifications—Passenger Car

MAKE OF CAR CHEVY II MODEL YEAR 1968 DATE ISSUED 10/15/67 REVISED (\*)

## WEIGHTS

NOVA Model	CURB WEIGHT - POUNDS			% PASS. WEIGHT DISTRIBUTION				SHIPPING WEIGHT
	Front	Rear	Total	Pass. In Front		Pass. In Rear		
				Front	Rear	Front	Rear	
<u>4-Cyl. Engine (153)</u>								
2-Door Cpe. (11127)	1500	1390	2890					2760
4-Door Sedan (11169)	1515	1405	2920					2790
<u>6-Cyl. Engine (230)</u>								
2-Door Cpe. (11327)	1620	1380	3000					2860
4-Door Sedan (11369)	1640	1390	3030					2890
<u>V8 Engine (307)</u>								
2-Door Cpe. (11427)	1735	1410	3145					2995
4-Door Sedan (11469)	1755	1420	3175					3025
<u>Accessories &amp; Equipment Differential Weights</u>								
Front Bucket Seats			+ 21					Remarks
Air Conditioning			+ 90					
Frnt. Compt. Flr. Console			+ 13					
Power Brakes			+ 7					
Frnt. Disc Brakes			+ 43					
25 Cu. In. 6 Cyl. Eng.			+ 20					
32 Cu. In. V-8 Eng.			+ 33					
350 Cu. In. V-8 Eng.			+ 112					
4-Spd. Transmission			+ 7					
Powerglide Trans.			+ 4				4 Cyl. engine	
			0				6 Cyl. engine	
			- 2				V-8 engine	
Dual Exhaust			+ 32					
Power Steering			- 30				With 6 Cyl.	
			+ 28				With V-8	
Heavy Duty Battery			+ 16					
Radio Player			+ 21					
16 AM			- 8					

# AMA Specifications—Passenger Car

## CAR AND BODY DIMENSIONS

### KEY SHEET

#### EXTERIOR CAR AND BODY DIMENSIONS

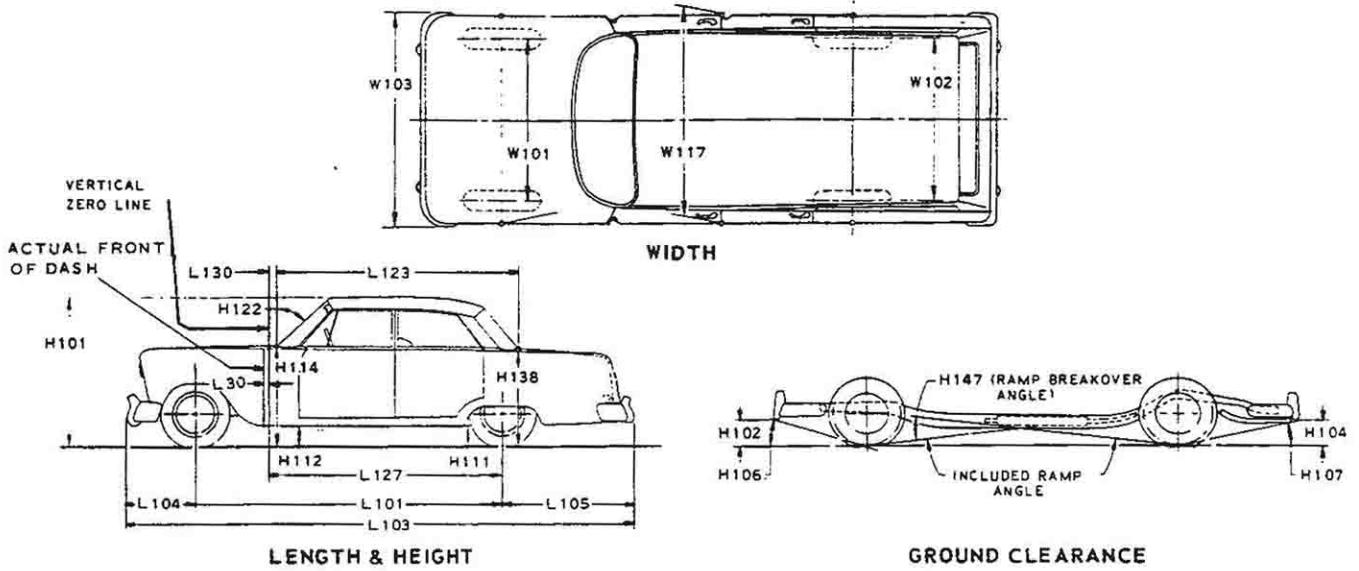

#### INTERIOR CAR AND BODY DIMENSIONS

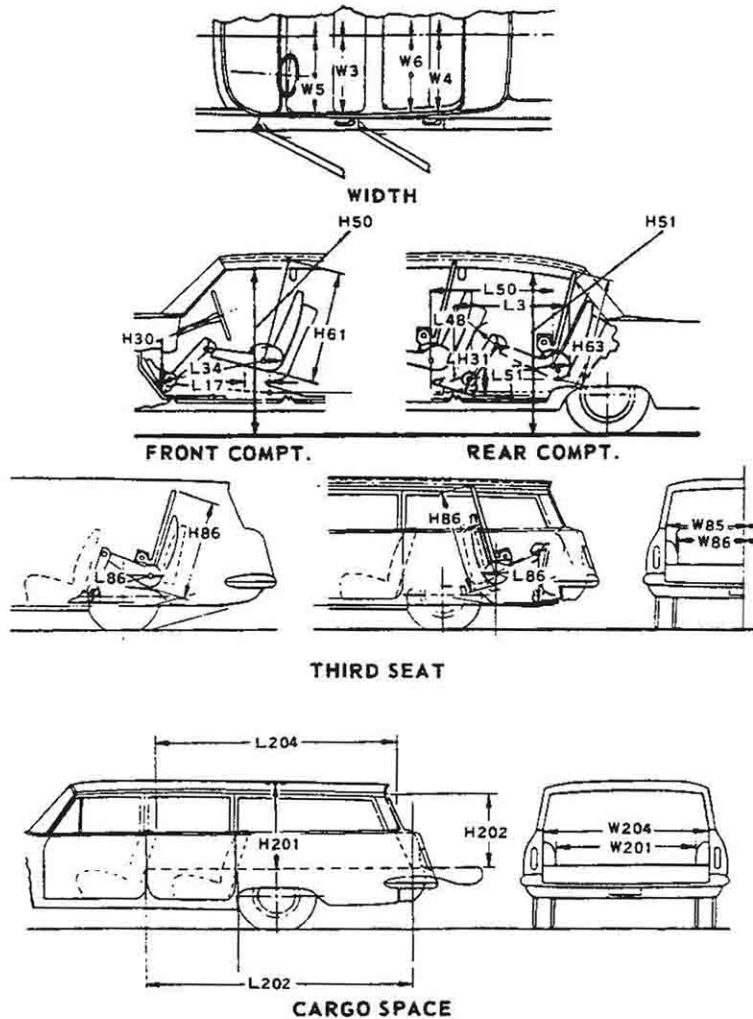

## CAR AND BODY DIMENSIONS

## KEY SHEET

## DIMENSION DEFINITIONS

## EXTERIOR WIDTH DIMENSIONS

- W101 WHEEL TREAD - FRONT. Measured at centerline of tires, with nominal camber, at ground.
- W102 WHEEL TREAD - REAR. Measured at centerline of tires at ground.
- W103 MAXIMUM OVERALL CAR WIDTH. Include bumpers, moldings, or sheet metal protrusions. Measured to outside of metal.
- W117 MAXIMUM BODY WIDTH AT #2 PILLAR. Measured across body at #2 pillar, excluding hardware and applied moldings.

## EXTERIOR LENGTH DIMENSIONS

- L 30 VERTICAL ZERO LINE TO ACTUAL FRONT OF DASH. If actual Front of Dash is to the rear of Body Zero Line, it is identified by a minus (-) sign.
- L101 WHEELBASE.
- L103 OVERALL LENGTH. Include bumper guards if standard equipment.
- L104 OVERHANG - FRONT. Measured from C/L of front wheels to front of car, including bumper guards if standard equipment.
- L105 OVERHANG - REAR. Measured from C/L of rear wheels to rear of car, including bumper guards if standard equipment.
- L123 BODY UPPER STRUCTURE LENGTH AT CAR CENTERLINE. The horizontal dimension from the Cowl Point to the Deck Point.
- L127 VERTICAL ZERO LINE TO CENTERLINE OF REAR WHEELS. A horizontal dimension.
- L130 VERTICAL ZERO LINE TO WINDSHIELD COWL POINT. The horizontal dimension from the vertical zero line to the theoretical intersection of extended windshield glass plane and normal cowl surface.

## EXTERIOR HEIGHT DIMENSIONS

- H101 OVERALL HEIGHT - DESIGN. Measured with the vehicle in Manufacturer's Design Weight attitude.
- H114 COWL POINT TO GROUND. Measured at vehicle centerline.
- H138 DECK POINT TO GROUND. Measured at vehicle centerline.
- H112 ROCKER PANEL TO GROUND - FRONT. The vertical dimension from ground to bottom of rocker panel, excluding flanges. Measured to the outside of sheet metal at foremost point of rocker panel.
- H111 ROCKER PANEL TO GROUND - REAR. The vertical dimension from ground to bottom of rocker panel, excluding flanges. Measured to the outside of sheet metal at front of rear wheel opening.
- H122 WINDSHIELD SLOPE ANGLE. The angle between a vertical line and the windshield surface at car centerline. On compound-curved windshields the chord of the arc is used and limited to that section of the windshield comprehended by an 18-inch chord.

## GROUND CLEARANCE DIMENSIONS

- H102 BUMPER TO GROUND - FRONT. Minimum dimension, includes bumper guards.
- H104 BUMPER TO GROUND - REAR. Minimum dimension, includes bumper guards.
- H106 ANGLE OF APPROACH. The angle between ground and a line tangent to the front tire static loaded radius arc and the first point of interference, i.e., bumper, guard, gravel deflector, fender or other component, excluding license plate. This dimension may be determined graphically for reporting purposes.
- H107 ANGLE OF DEPARTURE. The angle between ground and a line tangent to the rear tire static loaded radius arc and the first point of interference, i.e., bumper, guard, gravel deflector, tail pipe, fender, or other component, excluding license plate. This dimension may be determined graphically for reporting purposes.
- H147 RAMP BREAKOVER ANGLE. The supplement of included ramp angle (180° minus included ramp angle) over which car can pass without interference; measured with car sitting on a level surface, using lines tangent to arcs of front and rear static loaded radii and intersecting at point on underside of car which defines the smallest angle. This dimension may be determined by calculation (see Design Standard DD 0.00 - 108) or graphically for reporting purposes.
- H156 MINIMUM RUNNING GROUND CLEARANCE. Location of measurement on the car is to be clearly recorded.

## FRONT COMPARTMENT DIMENSIONS

- H 61 EFFECTIVE HEAD ROOM - FRONT. The dimension from H Point to the headlining, plus a constant of 4.0 inches, measured along a line 8° to rear of vertical.
- L 34 MAXIMUM EFFECTIVE LEG ROOM - ACCELERATOR. Measured along a diagonal line from the Manikin ankle pivot center to the H Point plus a constant of 10.0 inches. For treadle type accelerator pedals, the leg room is measured with the Manikin's right foot on the accelerator pedal and the Manikin Heel Point at Accelerator Heel Point. All other types of accelerator pedals will be measured with the Manikin foot angle set at 87° and the shoe touching the pedal.
- H 30 H POINT TO HEEL POINT - FRONT. The vertical dimension from the H Point to the Accelerator Heel Point.
- L 17 H POINT TRAVEL. The horizontal dimension between the H Point in the most forward and rearward seat positions.

## FRONT COMPARTMENT DIMENSIONS (Cont.)

- W 3 SHOULDER ROOM - FRONT. The minimum lateral dimensions between the door garnish moldings or nearest interference, measured at the H Point station.
- W 5 HIP ROOM - FRONT. The lateral dimension through the H Point to trimmed body surfaces. Depress loose side wall cloth to trim foundation or other obstruction if such construction exists.
- H 50 UPPER BODY OPENING TO GROUND - FRONT. The vertical dimension from a point on the trimmed body opening to the ground, measured at the H Point station.

## REAR COMPARTMENT DIMENSIONS

- L 50 H POINT COUPLE DISTANCE. The horizontal dimension from the front seat H Point to the rear seat H Point.
- H 63 EFFECTIVE HEAD ROOM - REAR. The dimension from the H Point to the headlining, plus a constant of 4.0 inches, measured along a line 8° to rear of vertical.
- L 51 MINIMUM EFFECTIVE LEG ROOM - REAR. Measured along a diagonal line from the ankle pivot center to the H Point plus a constant of 10.0 inches, with the foot positioned to the nearest interference between the seat structure and toe, instep or lower leg.
- H 31 H POINT TO HEEL POINT - REAR. The vertical dimension from the H Point to the Manikin Heel Point on the depressed floor covering.
- L 48 MINIMUM KNEE ROOM - REAR. The minimum dimension from the Manikin knee pivot center to the back of the front seat back.
- L 3 REAR COMPARTMENT ROOM. The horizontal dimension from the back of front seat to front of rear seat back at height tangent to the top of rear seat cushion.
- W 4 SHOULDER ROOM - REAR. The minimum lateral dimension between the door garnish molding or nearest interference. Measured at H Point station.
- W 6 HIP ROOM - REAR. The lateral dimension through H Point to trimmed body surfaces. Depress loose side wall cloth to trim foundation or other obstruction when such construction exists.
- H 51 UPPER BODY OPENING TO GROUND - REAR. The vertical dimension from a point on the trimmed body opening to the ground, measured 13.0 inches forward of the H Point.

## LUGGAGE COMPARTMENT DIMENSIONS

- V 1 LUGGAGE CAPACITY - USABLE. The total luggage compartment luggage capacity in cubic feet with the tire and tools in place, determined in accordance with the Passenger Car Luggage Space Standard, DD 0.00 - 105.
- H195 LIFTOVER HEIGHT. Vertical dimension from the highest point on the luggage compartment lower opening to ground, excluding corner radii.

## STATION WAGON - THIRD SEAT DIMENSIONS

- W 85 SHOULDER ROOM - THIRD SEAT. The minimum lateral dimension between the door garnish moldings or nearest interference. Measured at H Point station.
- W 86 HIP ROOM - THIRD SEAT. The lateral dimension through H Point to trimmed surfaces.
- L 86 EFFECTIVE LEG ROOM - THIRD SEAT. Measured along a diagonal line from ankle pivot center to H Point plus a constant of 10.0 inches. With rear-facing third seat, foot is positioned in foot well or to nearest interference with rear end or rear closure.
- H 86 EFFECTIVE HEAD ROOM - THIRD SEAT. The dimension from H Point to the headlining, plus a constant of 4.0 inches. Measured along a line 8° to rear of vertical.

## STATION WAGON - CARGO SPACE DIMENSIONS

- L202 CARGO LENGTH AT FLOOR - FRONT SEAT. The horizontal dimension, measured at the floor level from the rear of the front seat back to the normal inside limiting interference on the tailgate, on the car centerline.
- L204 CARGO LENGTH AT BELT - FRONT SEAT. The horizontal dimension measured from the top rear of front seat back to a vertical extension line from the normal inside limiting interference at the top of the tailgate, on the car centerline.
- W201 CARGO WIDTH - WHEELHOUSE. The minimum horizontal dimension, measured between wheelhouseings at floor level.
- W204 OPENING WIDTH AT BELT. The minimum horizontal dimension, measured between the nearest normal inside limiting interferences of the rear opening at the top of the tailgate.
- H201 MAXIMUM CARGO HEIGHT. The maximum vertical dimension, measured from the top of the floor covering to the headlining, on the car centerline.
- H202 REAR OPENING HEIGHT. The vertical dimension measured from the top of the floor covering to the normal inside limiting interference at the top of the rear opening, on the car centerline, with both tail-and liftgates fully open.
- V 2 CARGO VOLUME INDEX BEHIND FRONT SEAT. The total volume in cubic feet above the normal load floor and behind the front seat with the liftgate and tailgate closed.

W4xL204xH201

1728

## INDEX

SUBJECT	PAGE NO.	SUBJECT	PAGE NO.
Automatic Transmission	16	Kingpin (Steering Axis)	2
Axis, Steering	20	Lamp height and spacing	2
Axle, Rear	17	Legroom	
Battery	12	Lengths - Car and Body	
Bearings, Engine	5, 6, 7	Lifters, valve	
Belts - Fan, Generator, Water Pump	11	Linings - Clutch, Brake	14, 1
Brakes - Parking, Service Power	18, 19	Lubrication	7, 8, 14, 15, 16, 1
Camber	20	Luggage Compartment	
Camshaft	6	Motor, Starting	1
Capacities		Muffler	1
Cooling System	11	Overdrive	1
Fuel Tank	10	Piston Pins & Rings	4, 1
Lubricants		Pistons	4, 1
Engine Crankcase	8	Power Brakes	1
Transmission and Overdrive	15, 16	Power Steering	2
Rear Axle	17	Power Teams	
Car and Body Dimensions		Propeller Shaft, Universal Joints	16, 1
Width	1	Pumps - Oil, Fuel	8, 1
Length	1	Water	1
Height	1	Radiator, Hoses	1
Ground Clearance	1	Ratios - Axle	3, 1
Front Compartment	2	Compression	3, 1
Rear Compartment	2	Steering	2
Luggage Compartment	2	Transmission	15, 1
Station Wagon - Third Seat	2	Rear Axle	3, 1
Station Wagon - Cargo Space	2	Regulator - Generator	1
Carburetor	3, 9, 10	Rims	1
Caster	20	Rings, Piston	
Choke, Automatic	10	Rods - Connecting	
Clutch - Pedal Operated	14	Shock Absorbers, Front & Rear	2
Coil, Ignition	13	Spark Plugs	1
Connecting Rods	5	Speedometer	1
Convenience Equipment	23	Springs - Front & Rear Suspension	2
Cooling System	11	Valve, Engine	
Crankcase Ventilation System	8	Stabilizer (Sway Bar) - Front & Rear	2
Crankshaft	6	Starting System	1
Cylinders and Cylinder Head	4	Steering	2
Dimension Definitions		Supply System	1
Key Sheet	25	Suppression - Ignition, Radio	1
Exterior & Interior	26	Suspension - Front & Rear	2
Distributor - Ignition	13	Tail Pipe	
Electrical System	12, 13, 14	Thermostat, Cooling	1
Engine		Timing, Engine & Valve	6, 7, 1
Bore, Stroke, Displacement, Type	4	Tires	1
Compression Ratio	4	Toe in	2
Firing Order, Cylinder Numbering	4	Torque Converter	1
General Information, H.P. & Torque	4	Torque - Engine, Rated	3, 1
Lubrication	7, 8	Transmission - Types	3, 10, 15, 1
Power Teams	3	Automatic	3, 10, 15, 1
Exhaust Emission Control	9	Manual & Overdrive	3, 10, 1
Exhaust System	8	Ratios	15, 1
Equipment Availability	22	Track	
Fan, Cooling	11	Trunk Luggage Capacity	
Filters - Engine Oil, Fuel System	8, 10	Turning Diameter	2
Frame	22	Unitized Construction	2
Front Suspension	21	Universal Joints, Propeller Shaft	16, 1
Fuel, Fuel Pump, Fuel System	4, 10	Valves - Intake & Exhaust	6, 1
Fuel Injection	10	Vibration Damper	
Generator and Regulator	12	Voltage Regulator	1
Glass	22	Water Pump	1
Height (Lamps)	14	Weights - Shipping, Curb	2
Headroom - Body	2	Wheel Alignment	2
Heights - Car and Body	1	Wheelbase	
Horns	14	Wheels & Tires	1
Horsepower - Brake	3, 4	Wheel Spindle	2
Ignition System	13	Widths - Car and Body	
Inflation - Tires	18	Windshield	2
Instruments	14	Windshield Wiper	1