

AMA Specifications – Passenger Car

Data prepared and distributed by American automobile manufacturers, using uniform questionnaire form developed by car manufacturers under auspices of the Automobile Manufacturers Association.

MAKE OF CAR	OLDSMOBILE	MODEL YEAR	1958	DATE ISSUED		REVISED	
COMPANY							
<u>MODEL NAME</u>		<u>SYMBOL</u>		<u>MODEL NAME</u>		<u>SYMBOL</u>	
DYNAMIC 88		4-DOOR SEDAN	88				
SUPFR 88		4-DOOR SEDAN	S88				
NINETY EIGHT		4-DOOR SEDAN	98				

TABLE OF CONTENTS

General Specifications	1	Brakes	15	Station Wagon	24
Engine - Mechanical	2	Front Suspension & Steering	16	Body & Car - General	25
Electrical	8	Rear Suspension	18	Weights	26
Drive Units	12	Body Dimensions	19	Index	27

NOTES:

1. The specifications set forth herein are those in effect at the date of compilation and are subject to change without notice.

UNLESS OTHERWISE INDICATED:

- All specifications are standard for the models under which they are listed.
- Specifications apply basically to 4-door sedan or equivalent. Body dimensions shown on pages 19-24 include other body models available.
- All dimensions are nominal engineering dimensions.

GENERAL SPECIFICATIONS

MODEL	Additional Information Page No.:	88	SUPER 88	NINETY-EIGHT	
Wheelbase (L-101)	22	122.5	122.5	126.5	
Tread	Front (W-101)	59	59	59	
	Rear (W-102)	58	58	58	
Maximum Overall Dimensions	Length (L-103)	208.2	208.2	216.7	
	Width (W-103)	78.8	78.8	78.8	
	Height (H-101)	57.4	57.4	57.4	
Transmission— (Specify trade name - opt., not available)	Manual	STANDARD	STANDARD	N.A.	
	Overdrive	N.A.	N.A.	N.A.	
	Automatic	OPTIONAL	OPTIONAL	STANDARD	
Axle ratio	Manual	3.64:1	3.64:1	N.A.	
	Overdrive	N.A.	N.A.	N.A.	
	Automatic	3.07:1	3.23:1	3.42:1	
Tire size	15	8.50x14	8.50x14	8.50x14	
Engine	Type, no. cyl., valve arr.	90° V-8 O.H.	90° V-8 O.H.	90° V-8 O.H.	
	Fuel system (Carb. or Inj.)	CARBURETOR	CARBURETOR	CARBURETOR	
	Bore and stroke	4x3.689	4x3.689	4x3.689	
	Piston displ., cu. in.	371	371	371	
	Std. compression ratio	10:1	10:1	10:1	
	Max. bhp at engine rpm	2	265@4400	305@4600	305@4600
	Max. torque at rpm	2	390@2400	410@2800	410@2800

AMA Specifications – Passenger Car

MAKE OF CAR OLDSMOBILE **MODEL YEAR** 1958 **DATE ISSUED** _____ **REVISED** _____
MODEL _____ 88 S 88 98

ENGINE—GENERAL

Type, no. cyls., valve arr.		90° V8-O. H		
Bore and stroke		4x3.689		
Piston displacement, cu. in.		371		
Bore spacing (C/L to C/L)		4.625		
No. system (front to rear)	L. Bank	1-3-5-7		
	R. Bank	2-4-6-8		
Firing order		1-8-7-3-6-5-4-2		
Compres. ratio (nominal)	Standard	10:1		
	Optional	None		
Cylinder Head Material	Standard	Cast Iron		
	Optional	None		
Cylinder Sleeve - Wet, dry, none		None		
Number of mounting points	Front	One		
	Rear	Two		
Taxable $\frac{\text{Dia.}^2 \times \text{No. Cyl.}}{2.5}$ horsepower		51	51	51
Published max. bhp at engine RPM*	Standard	265@4400	305@4600	305@4600
	Optional	**	**	**
Published max. torque* (lb. ft. @ RPM)	Standard	390@2400	410@2800	410 @ 2800
	Optional	**	**	**
Recommended fuel regular - premium	Standard	Premium	Premium	Premium
	Optional	None	None	None
Recommended idle speed (neutral)		460 SM & HT	460 SM & HT	460 HT

ENGINE—PISTONS

Material	Aluminum Alloy
Description and finish	Auto-Thermic, Cam Grind, Tin Plate Steel Strut
Weight (piston only) oz.	25.22

* Max. bhp (brake horsepower) and max. torque corrected as defined by SAE Engine Test Code.

(Continued)

Rev. Form 6-57

** J-2 ENGINE-- 3- DUAL CARBURETORS

BHP@RPM--- 312@4600

TORQUE@RPM--- 415@2800

AMA Specifications – Passenger Car

MAKE OF CAR OLDSMOBILE **MODEL YEAR** 1958 **DATE ISSUED** _____ **REVISED** _____
MODEL _____ 88 S88 98

ENGINE PISTONS (Cont.)

Clearance (limits)	Top land		.028-.034
	Skirt	Top	.00075 to .00225
		Bottom	.00075 to .00125
Ring groove depth	No. 1 ring		Compression - .206-.213
	No. 2 ring		Compression - .206-.213
	No. 3 ring		Oil .196-.203
	No. 4 ring		None

ENGINE—RINGS

Function (top to bottom)	No. 1, oil or comp.		Compression
	No. 2, oil or comp.		Compression
	No. 3, oil or comp.		Oil
	No. 4, oil or comp.		None
Compression	Description - material, type, coating, etc.	Cast iron-upper ring chrome plated O. D. Taper Face.- Lower ring - Parco - Lubrite - Interrupted scraper groove	
	Width	No. 1- .0775-.0780	No. 2 - .0925-.0935
	Gap	.013 - .023	
Oil	Description - material, type, coating, etc.	Spring Steel - Two rails - chrome plated O. D. - Spacer- Black oxide	
	Width	Rails .0238 to .0252 each	Spacer - .1715 to .1815
	Gap	Rails .015 to .055	Spacer - None
Expanders		Oil Ring Spacer - P. C. Type 98-3 - SP unitized 4 pc.	

ENGINE—PISTON PINS

Material	SAE#1117 Steel (Modified) & SAE#1016 Spec.		
Length	3.126		
Diameter	.9803 - .9807		
Type	Locked in rod, in piston, floating, etc.	Full Floating	
	Bushing	In rod or piston	Rod
		Material	GM #4077 M- Bronze
Clearance	In piston	.0000 to .0002 loose	
	In rod	.0000 to .0003 loose	
Direction & amount offset in piston	.090 to R. H. of cylinder Bore Centerline		

ENGINE—CONNECTING RODS

Material	Steel SAE#1139		
Weight (oz.)	29.53		
Length (center to center)	6.623		
Bearing	Material & Type	Moraine 400 Aluminum with G. M. 3874 Babbit Overlay Steel Backed	
	Overall length	.821 - .831	
	Clearance (limits)	.0009 to .0030	
	End play	(.004 - .009 Preferred) .002 - .011 (2 rods per crankpin)	

AMA Specifications – Passenger Car

MAKE OF CAR OLDSMOBILE **MODEL YEAR** 1958 **DATE ISSUED** _____ **REVISED** _____
MODEL _____ 88 S88 98

ENGINE—CRANKSHAFT

Material		S. A. E. 1145 Steel (modified)		
Vibration damper type		Rubber Absorption		
End thrust taken by bearing (No.)		Rear upper	Rear Lower	
Crankshaft end play		.004 to .008		
Main bearing	Material & type	#1, 2, 3, 4 Front-Steel backed aluminum Moraine 400 with GM#3874-M Babbit overlay. #5 rear Steel backed Durex 100A with GM 4167-M Babbit overlay.		
	Clearance	(#1) .0003 to .0019 (#2).0005 to .0021 (#5).0015-.0030 (#3&4).0005-.0031		
	Journal dia. and bearing overall length	No. 1	2.75 x .818	
		No. 2	2.75 x .818	
		No. 3	2.75 x .818	
		No. 4	2.75 x .818	
		No. 5	2.75 x 1.195	
No. 6	None			
No. 7	None			
Dir. & amt. cyl. offset		None		
Crankpin journal diameter		2.25		

ENGINE—CAMSHAFT

Location		Center		
Material		Alloy Cast Iron		
Bearings	Material	Steel backed babbit or Cu, lead, bronze		
	Number	5		
Type of drive	Gear or chain	Chain		
	Crankshaft gear or sprocket material	S. A. E. #1140 Steel		
	Camshaft gear or sprocket material	Cast Iron		
	Timing chain	No. of links	48	
		Width	.84375	
Pitch		.500		

ENGINE—VALVE SYSTEM

Hydraulic lifters (Std, opt, NA)		STANDARD	
Special provision for valve rotation (intake, exhaust)		No	
Rocker ratio		1.8 to 1	
Operating tappet clearance (indicate hot or cold)	Intake	None	
	Exhaust	None	
Timing marks on fly-wheel, damper, other		Crankshaft Balancer	

(Continued)

AMA Specifications – Passenger Car

MAKE OF CAR OLDSMOBILE MODEL YEAR 1958 DATE ISSUED _____ REVISED _____
 MODEL 88 S88 98

ENGINE—VALVE SYSTEM (cont.)

Timing	Intake	Opens (^o BTC)	16 ^o 0' @ .00538 cam lift
		Closes (^o ABC)	45 ^o 0' @ .00749 cam lift
		Duration - deg.	
	Exhaust	Opens (^o BBC)	64 ^o 0' @ .00535 cam lift
		Closes (^o ATC)	20 ^o 0' @ .00749 cam lift
		Duration - deg.	
Valve opening overlap			
Intake	Material		Thompson - SAE #3140 Steel - Eaton SAE #8645 Steel
	Overall length		4.999
	Actual overall head dia.		1.750
	Angle of seat		45 ^o
	Seat insert material		None
	Stem diameter		.3425 - .3417
	Stem to guide clearance		.0017 to .0035
	Lift		.435
	Outer spring press. and length	Valve closed (lb. @ in.)	110# @ 1.837
		Valve open (lb. @ in.)	227# @ 1.437
	Inner spring press. and length	Valve closed (lb. @ in.)	None
		Valve open (lb. @ in.)	None
	Exhaust	Material	
Overall length		4.999	
Actual overall head dia.		1.5625	
Angle of seat		45 ^o	
Seat insert material		None	
Stem diameter		.3938 - .3930	
Stem to guide clearance		.0022 to .0040	
Lift		.437	
Outer spring press. and length		Valve closed (lb. @ in.)	110# @ 1.837
		Valve open (lb. @ in.)	227# @ 1.437
Inner spring press. and length	Valve closed (lb. @ in.)	None	
	Valve open (lb. @ in.)	None	

ENGINE—LUBRICATION SYSTEM

Type of lubrication (splash, pressure, nozzle)	Main bearings	Pressure
	Connecting rods	Pressure
	Piston pins	Splash
	Camshaft bearings	Pressure
	Tappets	Pressure
	Timing gear or chain	Pressure
	Cylinder walls	Pressure

(Continued)

Rev. Form 6-57

AMA Specifications – Passenger Car

MAKE OF CAR	OLDSMOBILE	MODEL YEAR	1958	DATE: ISSUED		REVISED	
MODEL	88		S88				98

ENGINE—LUBRICATION SYSTEM (cont.)

Oil pump type	Gear
Normal oil pressure (lb. @ engine rpm)	35 - 45 at 50 M. P. H.
Oil pressure sending unit (electric or mechanical)	Electric
Type oil intake (floating, stationary)	Stationary
Oil filter system (full flow, partial, other)	Full Flow
Filter replacement (element, complete)	Element
Capacity of crankcase, less filter-refill (qt.)	4 quarts
Oil grade recommended (SAE viscosity and temperature range)	Not lower than 32° F - S. A. E. 20 or 20w as low as 10° F - S. A. E. 20w as low as 10° F - S. A. E. 10w Lower than 10° F - S. A. E. 5w
Oil type recommended	Heavy Duty

ENGINE—EXHAUST SYSTEM

	88	588	98
Type (single, single with cross-over, dual, other)	Single with cross over Dual optional	Single with cross over Dual optional	Dual
Muffler No. & type (reverse flow, straight thru, separate resonator)	Rev. Flow		
Exhaust pipe dia. (O.D. wall thickness)	Branch	2" O. D. x .076	
	Main	2.25 O. D. x .076	
Tail pipe diameter (O.D. & wall thickness)	2" O. D. x .054		

ENGINE—FUEL SYSTEM

(See Supplement to Page 6 for Details of Fuel Injection, Supercharger, etc. If used)

Induction type: Carburetor, fuel injection, supercharger.	Carburetor				
Fuel Tank	Capacity (gals.)	20 gallons			
	Filler location	Ahead left rear tail lamp			
Fuel Pump	Type (elec. or mech.)	Mechanical			
	Locations	Engine Front Cover			
	Pressure range	5# to 6# at 16" above outlet at 1800 R. P. M			
Vacuum booster (std., optional, none)	Standard				
Fuel Filter	Type	Accreted & Saran type			
	Locations	Fuel Pump & Gas Tank			
* Carburetor	Make & Model No.	Rochester 2 GC	Rochester 4 GC	Rochester 4 GC	
	Number & Type	1 Dual	1 quad.	1 quad.	
	Barrel size	1 7/16	1 9/16 Prim.	1 11/16 Sec. 1 9/16 Prim. 1 11/16 Sec.	
	Choke type	Automatic	Automatic	Automatic	
	Intake manifold heat control (exhaust or water)	Automatic	Automatic	Automatic	
	Air clnr. type	Standard	Alum. Foil Element	Paper Element	Paper Element
		Optional	Paper Element	None	None

* (3) 2 GC Carburetor option available on J-2 Engine All Models

AMA Specifications – Passenger Car

MAKE OF CAR OLDSMOBILE **MODEL YEAR** 1958 **DATE ISSUED** _____ **REVISED** _____
MODEL _____ 88 S88 98

ENGINE—COOLING SYSTEM

Type (pressure system, atmospheric, other)		Pressure System	
Radiator cap relief valve pressure		13 pounds (15# on Air Conditioned cars)	
Circulation thermostat	Type (choke, bypass)	Choke	
	Starts to open at (°F)	157° - 162°	
Water pump	Type (centrifugal, other)	Centrifugal	
	Number of pumps	One	
	Drive (V-belt, other)	V - Belt	
	Bearing type	Ball - Bearing	
By-pass recirculation type (internal, external)		Internal	
Radiator core type (cellular, tube and fin, other)		Tube & Center	
Cooling system capacity	With heater (qt.)	21 quarts	
	Without heater (qt.)	20	
	Opt. equipment-specify (qt.)	None	
Water jackets full length of cylinder (yes, no)		Yes	
Water all around cylinder (yes, no)		Yes	
Radiator hose	Lower	Number and type (molded, straight)	S. A. E. 20 R 4 class R - Grade 1 A Coolant Hose One - Molded Modified
		Inside diameter	1.75
	Upper	Number and type (molded, straight)	S. A. E. 20 R 4 class R Grade 1 A One - Molded - Modified
		Inside diameter	1.50
	By-pass	Number and type (molded, straight)	None
		Inside diameter	None
	Fan	Number of blades & Spacing	Four - 76° and 104°
		Diameter	19.25
Ratio-fan to crankshaft rev.		.817:1	
Fan cutout type		None	
Bearing type		Ball	
*Drive belts (indicate belt used by letter)	Fan	(A)	
	Generator	(B)	
	Water Pump	(C)	
	Power Steering	(D)	
	Air Conditioning	(E)	

Rev. Form 6-57

*Drive Belt Dimensions	A	B	C	D	E
Angle of V	36°	36°	36°	36°	36°
Nominal length (SAE)	57.5	57.5	57.5	56.31	68.06
Width	.380	.380	.380	.380	.380

AMA Specifications – Passenger Car

MAKE OF CAR OLDSMOBILE MODEL YEAR 1958 DATE ISSUED _____ REVISED _____
 MODEL 88 S 88 98 air conditioned models

ELECTRICAL—SUPPLY SYSTEM

Battery	Make and Model		Delco - Remy 3KMR 70	
	Voltage Rtg. & Plates/cell		12 volts - 11 plate	
	SAE Designation & Amp Hr. Rtg		70 Amp. Hr. RTG	
	Location		Under hood left side	
	Terminal grounded		Negative	
Generator	Make		Delco - Remy	Delco - Remy
	Model		*1102092	1102093
	Type		Shunt	Shunt
	Ratio—Gen. to Cr/s rev.		2.24:100	2.83:100
	Gen. cut-in—engine rpm		515	485
Regulator	Make		Delco - Remy	Delco - Remy
	Model		**1119002	1119600
	Type		Current & Voltage Control	Voltage & Current
	Cutout relay	Closing voltage @ generator rpm	12.8 at opening Temp. of 80°	
		Reverse current to open	0 to 4 Amp.	0 to 4 Amp.
	Regulated	Voltage	Set to 14.5	14.5
		Current	Set to 35 Amps.	
	Voltage test conditions	Temperature	Set at operating temp. of 80°F	
Load		1-10 Amp.		
Other		Cycle Regulator		

ELECTRICAL—STARTING SYSTEM

Starting motor	Make		Delco - Remy	
	Model		1107665	
	Rotation (drive end view)		Clockwise	
	Engine cranking speed		Summer 150 R. P. M.	
	Test conditions		S. A. E 20 with engine completely warm	
	Lock test	Amps	None	
		Volts	None	
		Torque (lb. ft.)	None	
	No load test	Amps	100	
		Volts	10.6	
RPM (min.)		3600		
Motor control	Switch (solenoid, manual)		Solenoid	
	Starting procedure		Turn ignition key to right against spring	

* 40 Amp. Generator used on air conditioned cars

** 40 Amp. Regulator used on air conditioned cars

AMA Specifications – Passenger Car

MAKE OF CAR	OLDSMOBILE	MODEL YEAR	1958
		DATE: ISSUED	REVISED
MODEL	88	S 88	98

ELECTRICAL—STARTING SYSTEM (cont.)

Motor drive	Engagement type	Helical Spline Sliding Gear Overrunning Clutch		
	Pinion meshes (front, rear)	Front		
	Number of teeth	Pinion	9	
		Flywheel	176	
Flywheel tooth face width		.450 - .440		

ELECTRICAL—IGNITION SYSTEM

Coil	Make	Delco - Remy		
	Model	1115104		
	Amps	Engine stopped	4.5 (with resistor)	
Engine idling		2.0 (with resistor)		
Distributor	Make	Delco - Remy		
	Model	1110929		
	Spark adv. centrifugal (crankshaft degrees)	Start (rpm)	0° to 4° @ 800 R. P. M.	
		Intermediate points @ rpm	13.5° to 17.5° @ 2000 R. P. M. 16° to 20° @ 2400 R. P. M.	
		Max. @ rpm	22° to 26° @ 4400 R. P. M.	
	Spark adv. vacuum (crankshaft degrees)	Start (in. Hg)	8.0" to 10.0" HG	
		Intermediate points, deg. @ rpm	10° @ 8" to 10.5" HG 15° @ 10.5 to 13.5" HG	
		Max. @ rpm.	18.5 to 21.5 @ 16" HG	
	Breaker gap (in.)		.016	
	Cam angle (deg.)		28 to 32°	
Breaker arm tension (oz.)		19 to 23 oz.		
Timing	Crankshaft deg. @ rpm.	5° BTC @ 850 R. P. M. With Vacuum Line Disconnected		
	Mark location	VIBRATION DAMPER		
	Cylinder numbering system (see page 2)	RIGHT BANK	2-4-6-8	
		LEFT BANK	1-3-5-7	
Firing order (see page 2)		1-8-7-3-6-5-4-2		
Spark Plug	Make and model		AC - 44	
	Thread (mm)		14 mm	
	Tightening torque (lb. ft.)		23-28 FT. LBS.	
	Gap		.030	
Cable	Conductor type		Resistance Core	
	Insulation type		Neoprene	
	Spark plug protector		Silastic Sleeve	

ELECTRICAL—SUPPRESSION

Description	Resistant type spark plug Cables: nominal 4000 OHMS per foot.
-------------	--

AMA Specifications – Passenger Car

MAKE OF CAR OLDSMOBILE **MODEL YEAR** 1958 **DATE ISSUED** _____ **REVISED** _____

MODEL _____ 88 _____ S88 _____ 98 _____

ELECTRICAL—LAMP BULBS

Give quantity used and trade number, e.g., Headlamp 2-5400 S, dual headlight 2-4001, 2-4002. Indicate accessories which are not standard equipment by an asterisk following the numbers.

Headlamps & arrangement	DUAL HEADLIGHTS - 2- 4001, 2-4002	
Headlamp beam indicator	1 - 57	
Parking light	2 - 1034	
Tail light	2 - 1034	
Stop light	2 - 1034 ALSO TURN SIGNAL	
Direction signal	Front	2 - 1034
	Rear	2 - 1034
	Indicator	2 - 57
License plate light	1 - 67	
Instrument light	2 - 57	
Ignition lock light	1 - 53	
Back up light	2 - 1073 *	
Dome light	1 - 1004 Except All 98; 88CR, HW, S88, DHW, DCR, DHC, DHS	
Clock light	1 - 57 * (Std. on 98)	
Radio light	1 - 189 I*	
Glove compartment light	1 - 57	
Escutcheon	2 - 53 Except 88	
Ash Tray Lt.	2 - 53	
Courtesy Lt.	2 - 90 * (Std. on S88 and 98)	
Heat & Vent Lt.	2 - 57 *	
Brake Warn.	1 - 57* (Std. on S88 and 98)	
Dome Lt.	2 - 90 All 98 and S88 Hardtops	
Dome Lt.	2 - 68 All Convertibles	

ELECTRICAL—FUSE & CIRCUIT BREAKER DATA

Use trade number of fuse, e.g., SFE-10. Indicate circuit breaker by ampere capacity suffixed by letters "C.B." e.g., 30 C.B. Where fuse or circuit breaker protects multiple circuits indicate first use by a letter and repeat the same letter for all units protected by the same fuse or circuit breaker, e.g., Parking lights SFE-10 (a), Direction Indicator same as (a).

Headlamp	25 CB (a)
Headlamp beam indicator	SAME AS (a)
Parking light	SAME AS (a)
Tail light	SFE 9 (b)
Stop light	3 AG 20(c) 3 AG25 98 DS & DHS
Direction indicator	SFE 9
License plate light	SAME AS (b)
Instrument light	1 AG 3 (d)
Ignition light	SAME AS (d)
Back up light	SFE 14 (e)
Dome light	SAME AS (c)
Clock	1 AG 1
Clock light	SAME AS (d)
Radio	AGW 4 Deluxe AGW 7.5 Super Deluxe
Glove compartment light	SAME AS (b)
Heater	SFE 20
Air condition'g	3 AG-25
Electric Wind.	SFE 20(f)
Electric Ant.	SAME AS (f)
Electric Wiper	SFE 20

AMA Specifications – Passenger Car

MAKE OF CAR OLDSMOBILE **MODEL YEAR** 1958 **DATE: ISSUED** _____ **REVISED** _____
MODEL _____ 88 & S88 _____ 98

DRIVE UNITS—CLUTCH (Manual Transmission)

Make & type		LONG MFG. - DRY SEMI-CENTRIFUGAL	NA
Type pressure plate springs		COMPRESSION	
Total plate pressure (lb.)		1934# @ 2800 R. P. M.	
No. of clutch driven discs		ONE	
Clutch facing	Material	WOVEN MOLDED	
	Outside & inside dia.	11"x7"	
	Total eff. area (sq.in.)	56.52	
	Thickness	.385 MAX.	
	Engagement cushioning method	FLAT SPRINGS BETWEEN FACINGS	
Release bearing	Type & method of lubrication	BALL - PRESSURE GUN FITTING	
Torsional damping	Methods: springs, friction material	SPRINGS - STEEL FRICTION PLATES	

DRIVE UNITS—TRANSMISSIONS

Manual (std. or opt.)	STD.	NA
Manual with overdrive (std. or opt.)	NA	NA
Automatic (std. or opt.)	OPT.	STD.

DRIVE UNITS—MANUAL TRANSMISSION

Number of forward speeds		3 SPEED	NA	
Transmission ratios	In first	2.1527:1		
	In second	1.3725:1		
	In third	1:1		
	In fourth	None		
	In reverse	2.2793:1		
Synchronous meshing, specify gears		2nd & 3rd		
Lubricant	Capacity (pt.)	2.5		
	Type recommended	Multi Purpose Gear Lube		
	SAE viscosity number	Summer	S. A. E. - 80	
		Winter	S. A. E. - 80	
Extreme cold		S. A. E. -80		

MAKE OF CAR OLDSMOBILE MODEL YEAR 1958 DATE ISSUED _____ REVISED _____
 AODEL _____ ALL _____

DRIVE UNITS—MANUAL TRANSMISSION WITH OVERDRIVE

For transmission data see manual transmission section NOT AVAILABLE

Overdrive	Type (planetary or other)			
	Manual lockout (yes, no)			
	Downshift accelerator control (yes, no)			
	Minimum cut-in speed			
	Gear ratio			
	Lu- bri- cant	Capacity (Overdrive only)		
		Separate filler (yes, no)		
		Type recommended		
		SAE vis- cosity number	Summer	
			Winter	
Ext. cold				

DRIVE UNITS—AUTOMATIC TRANSMISSION

Trade name	HYDRA-MATIC			
Type describe	FLUID COUPLINGS WITH PLANETARY GEARS			
Method of Selection (Lever, Push Button or other)	LEVER			
Selector Pattern	P-N-D-S-L-R			
1st gear ratios Selector Pattern and indicate which are used in each selector position	DRIVE	SUPER	LOW	REVERSE
	3.9666:1	3.9666:1	3.9666:1	3.7395:1
	2.5532:1	2.5532:1	2.5532:1	
* FORCED UPSHIFT @ 47. MPH	1.5536:1	1.5536:1	* 1.5536:1	
** FORCED UPSHIFT @ 72. MPH	1.0000:1	**1.0000:1	**1.0000:1	
Max. upshift speeds—drive range	70-75 MPH			
Max. kickdown speeds—drive range	65-70 MPH			
Torque convertor	Number of elements		NA	
	Max. ratio at stall at engine rpm		NA	
	Type of cooling (air, water)		NA	
Lubricant	Capacity—refill (pt.)		22	
	Type recommended		TYPE "A" AUTOMATIC TRANS. FLUID	
Special transmission features	A SMALL FLUID COUPLING FILLS & DUMPS TO CONTROL THE FRONT PLANETARY UNIT. TRANSMISSION OIL COOLER IS PROVIDED FOR SEVERE OPERATING CONDITIONS.			

AMA Specifications – Passenger Car

MAKE OF CAR OLDSMOBILE **MODEL YEAR** 1958 **DATE ISSUED** _____ **REVISED** _____

MODEL _____ 88 _____ S88 _____ 98

DRIVE UNITS—PROPELLER SHAFT

Number used		TWO PIECE	
Type (exposed, torque tube)		EXPOSED	
Outer diameter x length* x wall thickness	Manual transmission	2.25x28.67x.095 2.25x32.125x.095	N. A.
	Overdrive transmission	NOT AVAILABLE	
	Automatic transmission	2.25x28.67x.095 - 2.25x32.125x.095-99-S88 2.25x28.67x.095 - 2.25x36.125x.095-98	
Inter-mediate bearing	Type (plain, anti-friction)	A/F BALL BEARING	
	Lubrication (fitting, prepack)	PRE PACK	
Universal joints	Make	SAGINAW STEERING GEAR	
	Number used	3	
	Type (ball and trunion, cross, other)	CROSS	
	Bearing	Type (plain, anti-friction)	NEEDLE
Lubric. (fitting, prepack)		PRE PACK	
Drive taken through (torque tube or arms, springs)		SPRING	
Torque taken through (torque tube or arms, springs)		SPRING	

DRIVE UNITS—REAR AXLE

Description - (incl. limited slip differential)		SEMI-FLOATING HYPOID			
Drive Pinion Offset		1.75	1.75	1.75	
No. of differential pinions		2	2	2	
Gear ratio and No. of teeth	Automatic transmission	3.07 (40:13)	3.23 (42:13)	3.42 (41:12)	
	Overdrive trans.	NA	NA	NA	
	Manual transmission	3.64 (40:11)	3.64 (40:11)	NA	
Ring gear pitch diameter & O.D.		9.25 P. D. - 9.30. OD	9.25 P.D. -9.30. OD	9.25 P. D-9.30. OD	
Pinion adjustment (shim, other)		SHIMS			
Pinion bearing adj. (shim, other)		SPACER & NUT			
Wheel bearing type		SEALED BALL			
Lubricant	Capacity (pt.)	5.25	5.25	5.25	
	Type recommended	MULTI-PURPOSE HYPOID LUBRICANT			
	SAE viscosity number	Summer	S. A. E. - 90		
		Winter	S. A. E. - 90		
Extreme cold		S. A. E. - 90			

*Center to center of universal joints, or to centerline of rear attachment.

AMA Specifications – Passenger Car

MAKE OF CAR OLDSMOBILE MODEL YEAR 1958 DATE ISSUED _____ REVISED _____
 MODEL _____ 88 _____ S88 _____ 98 _____

DRIVE UNITS—WHEELS

Type & material		STEEL DISC
Rim (size and flange type)		14 x 6k
Attachment	Type (bolt or stud)	STUD
	Circle diameter	5
	Number and size	5-1/2

DRIVE UNITS—TIRES

Size (L-102) & ply rating	Standard	8.50 x 14	8.50 x 14	8.50 x 14
	Optional	9.00 x 14	9.00 x 14	9.00 x 14
Type tires - nylon, etc.		RAYON	RAYON	RAYON
Rev/mile at 30 mph		735	735	735
Inflation press.(cold)	Front	*22	*22	*22
	Rear	20	20	20

BRAKES—SERVICE

Type		MORaine		
Power brake type		OPTIONAL		
Effective area (sq. in.)		191.7		
Percent brake effectiveness-front		44%		
Drum	Diameter	Front	11 x 2 1/2	
		Rear	11 x 2	
	Type and material		CAST IRON & STEEL CENTRIFUSE	
Bonded or riveted		RIVETED		
Brake lining	Front Shoe	Material	MARSHAL 4641	
		Size (length x width x thickness)	Front wheel	9 3/8 x 2 1/2 x 1/4
			Rear wheel	9 3/8 x 2 x 1/4
	Segments per shoe		ONE	
	Rear Shoe	Material	MARSHAL 9795D	
		Size (length x width x thickness)	Front wheel	12 1/32 x 2 1/2 x 1/4
			Rear wheel	12 1/32 x 2 x 1/4
Segments per shoe		ONE		
Wheel cyl-inder bore	Front	1 3/32		
	Rear	31/32		
Master cylinder bore		1"		
Available pedal travel		6 1/2		
Line pressure at 100 lb. pedal load		735 APP.		
Shoe clearance adjustment		.015		

* Air Conditioning 24 lbs. front

AMA Specifications – Passenger Car

MAKE OF CAR OLDSMOBILE **MODEL YEAR** 1958 **DATE ISSUED** _____ **REVISED** _____
MODEL _____ 88 S88 98

BRAKES--PARKING

Type of control		FOOT PEDAL CONTROL
Location of control		LEFT OF STEERING COLUMN
Operates on		REAR
If separate from service brakes	Type (internal or external)	INTERNAL
	Drum diameter	11"
	Lining size (length x width x thickness)	PRIMARY 9 3/8 x 2 x 1/4-- SECONDARY 12 1/32 x 2 x 1/4

FRAME or UNITIZED CONSTRUCTION

Type and description	DEEP CHANNEL SECTION SIDE RAILS & SIDE-BARS, I BEAM "X" MEMBERS & FIVE CROSS BARS
----------------------	---

SUSPENSION--GENERAL

Provision for car leveling		AIR RIDE CARS ONLY
Provision for brake dip control		ANTI-DIVE - FRONT SUSP. GEOMETRY
Provision for acc. squat control		NONE
Special provisions for car jacking		NONE
Shock absorber front & rear	Type	DIRECT
	Make	DELCO
	Piston dia.	1"
Other special features		NONE

SUSPENSION--FRONT

Type and description	INDEPENDENT COIL SPRING STD. CAR. (OPTIONAL) INDEPENDENT AIR SPRING (AIR RIDE)
----------------------	--

(Continued)

Rev. Form 6-57

AMA Specifications – Passenger Car

MAKE OF CAR OLDSMOBILE **MODEL YEAR** 1958 **DATE: ISSUED** _____ **REVISED** _____
MODEL _____ 88 S88 98

SUSPENSION FRONT (cont.)

Spring	Type		COIL		
	Material		GM9260 M SPG. STL.		
	Size (coil design height & I.D.; bar length x dia.)		43/64	4 3/64	4 3/64
	Spring rate (lb. per in.)		300	300	300
	Rate at wheel (lb. per in.)		100	100	100
Design load (lb. @ design height)		2345	2415	2485	
Stabilizer	Type (link, linkless, frameless)		LINK		
	Material & bar diameter		SAE 1070		

STEERING

Mechanical (std., opt., NA)			STANDARD	STANDARD	N. A.	
Power (std., opt., NA)			OPTIONAL	OPTIONAL	STANDARD	
Wheel diameter			17.50	17.50	17.50	
Turning diameter	Outside front	Wall to wall (l. & r.)	44.83	44.83 Ft.	46.54 Ft.	
		Curb to curb (l. & r.)	42.00 Ft.	42.00 Ft.	43.00 Ft.	
	Inside rear	Wall to wall (l. & r.)	26.18 Ft.	26.18 Ft.	27.58 Ft.	
		Curb to curb (l. & r.)	26.52 Ft.	26.52 Ft.	27.83 Ft.	
Outside wheel angle with inside wheel at 20°			23°	23°	23°	
Mechanical	Gear	Type		BALL NUT	BALL NUT	N. A.
		Make		SAGINAW	SAGINAW	N. A.
		Ratios	Gear	23.6	23.6	N. A.
			Overall	29.9	29.9	N. A.
	No. wheel turns		4 3/4	4 3/4	N. A.	
Power	Type		HYDRAULIC BOOSTER			
	Make		SAGINAW			
	Trade name		POWER STEERING			
	Gear	Type		BALL NUT		
		Ratios	Gear	19:1		
			Overall	22.7:1		
	Pump driven by		BELT FROM CRANK			
	Overall torque ratio		VARIABLE			
Number wheel turns		4				
Linkage	Type		SYMMETRICAL			
	Location (front or rear of wheels, other)		REAR			
	Drag link (trans. or longit.)		TRANSVERSE			
	Tie rods (one or two)		TWO			

(Continued)

Rev. Form 6-57

AMA Specifications – Passenger Car

MAKE OF CAR OLDSMOBILE **MODEL YEAR** 1958 **DATE ISSUED** _____ **REVISED** _____
MODEL _____ 88 S88 98

STEERING (cont.)

Steering Axis	Inclination at camber (deg.)		7° @ 0° CAMBER
	Bearings (type)	Upper	NONE
		Lower	NONE
	Thrust		NONE
Wheel alignment (range and preferred)	Caster (deg.)		0° To 1° NEGATIVE
	Camber (deg.)		1/4° NEGATIVE TO 3/4° POSITIVE
	Toe-in (outside tread-inches)		.00 To 12
Steering spindle & joint type			
Wheel spindle	Diameter	Inner bearing	1.3736/1.3741
		Outer bearing	.8427/.8432
	Thread size		13/16-16
	Bearing type		BALL & CONE

SUSPENSION—REAR

Type and description		LONGITUDINAL			
Drive and torq. taken through (see page 14)		SPRINGS			
Spring	Type	SEMI-ELLIPTIC			
	Material	AISI #9260 or AISI #5160 or AISI #5155			
	Size (length x width, coil design height and I.D.; bar length & dia.)	58 x 2 1/2" - 5			
	Spring rate (lb. per in.)	95	95	100	
	Rate at wheel (lb. per in.)	115	115	120	
	Design load (lb. at design height)	985-1.20	985-1.20	1000-1.20	
	Mounting insulation type		RUBBER		
	If leaf	No. of leaves		5	
Inserts		Type and size		FULL LENGTH	
		Material		COMPOSITION	
Shackle (comp. or tens.)		COMPOSITION			
Stabilizer	Type (link, linkless, frameless)		NONE		
	Material		NONE		
Track bar type		NONE			

MAKE OF CAR OLDSMOBILE **MODEL YEAR** 1958 **DATE: ISSUED** _____ **REVISED** _____

BODY—GENERAL DEFINITIONS

NOTE: Included in the dimension definitions listed on this and the following pages are those which have been adopted by the S.A.E. These are indicated by a number following the type of dimension, e.g. L 3. Additional dimensions have been added by the AMA Specifications Body Sub-Committee for inclusion in the Questionnaire. These are shown by an additional letter, e.g., HA. Symbol "a" added as suffix to SAE dimensions indicates an AMA modification. The dimensions are developed from the following basic points:

1. Front and rear seat free "A" points are taken 5" forward of vertical tangent to seat back 15" from center of body.
2. Front and rear seat "B" points are located on seat back 15" from center of body at height of horizontal tangent to top of seat cushion.
3. Front seat is in the full down and normal rearmost position.
4. Loaded position—5 passenger, front 300 lb., rear 450 lb.; includes spare wheel, tire and tools, and full complement of gas, oil, water, and tires to recommended pressure, etc.
5. C/L (centerline).
6. D. L. O. (daylight opening, exposed glass dimension - pages 21, 23 & 25).
7. Rump breakover angle (page 21) is the supplement of the included ramp angle (180° minus the included ramp angle) over which a car can pass without hanging up.

MODEL	88	S 88		98
--------------	----	------	--	----

BODY—TRUNK DIMENSIONS

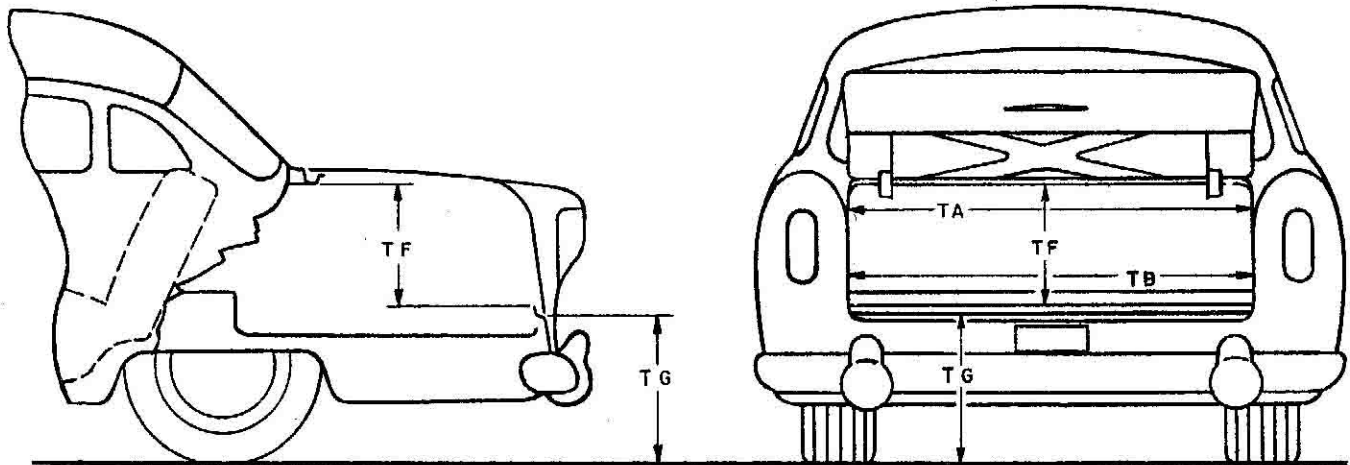

Usable trunk luggage capacity (see Section H1 of SAE Automotive Drafting Standards)	10.7	10.7	13.2
TA—Width across the top	46.8	46.8	46.8
TB—Width across the bottom	46.8	46.8	46.8
TF—Vertical dimension at C/L from bottom to top of opening.	15.7	15.7	15.7
TG—Vertical height from ground to trunk lower opening (normal surface of outside sheet metal - loaded)	23.0	23.0	23.0
Position of spare tire stowage	RIGHT SIDE, VERTICAL		
Method of holding lid open	TORSION ROD		

AMA Specifications – Passenger Car

MAKE OF CAR OLDSMOBILE MODEL YEAR 1958 DATE ISSUED _____ REVISED _____
 MODEL _____ 88 S 88 98

BODY—HEIGHT DIMENSIONS--INTERIOR

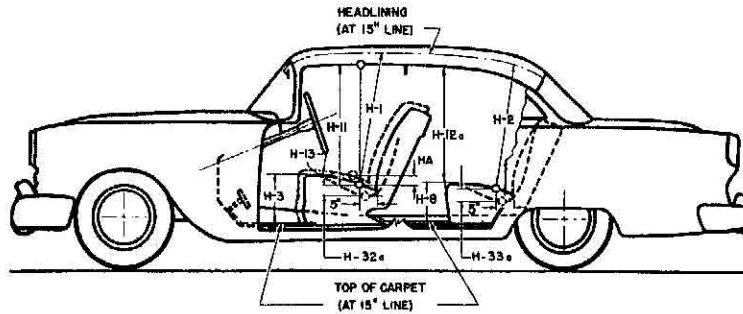

H1. Front headroom—from free "A" pt. to headlining at 8° back of vertical on 15" line. (For "A" pt. see note 1, page 19)	35.1	34.6	34.6
H2. Rear headroom—from free "A" pt. to headlining at 8° back of vertical on 15" line.	33.5	33.5	33.1
H3. Front cushion height above low point on floor carpet on 15" line (front edge of cushion).	11.2	11.2	11.2
H8. Rear cushion height above low point on floor carpet on 15" line (front edge of cushion).	11.8	11.6	11.9
H11. Entrance—front—cushion free "A" point to bottom windcord vertical.	28.6	28.2	28.2
H12a. Entrance — rear — top of cushion at vertical tangent to front of rear seat, to bottom of windcord in rear.	26.5	26.5	26.2
H13. Steering wheel clearance to seat cushion taken on arc (wheel turned for min. clearance).	5.5	5.1	5.1
HA. Front seat maximum vertical rise at free "A" point.	.4	.4	.4
HF. Front seat maximum vertical rise of free "A" point with multiple-position seat.	2.0	2.0	2.0
H32a. Front seat depressed depth — vertical dimension from free "A" point to depressed "A" point.	4.3	4.4	4.4
H33a. Rear seat depressed depth — vertical dimension from free "A" point to depressed "A" point.	3.9	4.4	4.4

AMA Specifications – Passenger Car

MAKE OF CAR OLDSMOBILE MODEL YEAR 1958 DATE: ISSUED _____ REVISED _____
 MODEL _____ 88 88 98

BODY—HEIGHT DIMENSIONS—EXTERIOR

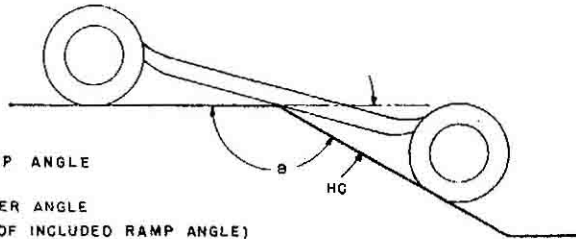
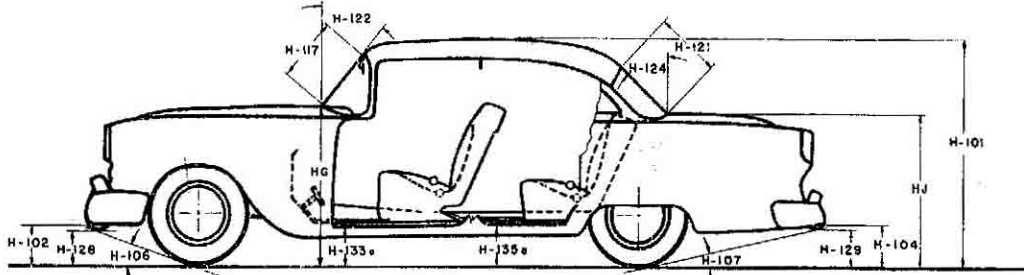

H101. Overall height - loaded.	57.4	57.4	57.4
HB. Overall height - curb weight.	59.0	59.0	59.0
H102. Front bumper bottom to ground at normal section.	10.3	10.3	10.3
H104. Rear bumper bottom to ground at normal section.	10.2	10.2	10.2
H106. Angle of appr.-fr. tire static loaded rad. to interfering pt. on fr. bumper, gd., other.	21°45'	21°45'	21°45'
H107. Angle of dep.-fr. tire static loaded rad. to interfering pt. on rr. bumper, gd., other.	13°45'	13°45'	12°50'
HC. Ramp breakover angle.*	12°19'	12°19'	11°50'
H117. Windshield DLO-slant height.	18.7	18.7	18.7
H121. Backlight DLO*-max., slant height.	18.2	18.2	18.2
H122. Windshield slope angle to vertical line on car axis.	47°30'	47°30'	47°30'
H124. Backlight slope angle to vertical line on car axis.	54°30'	54°30'	54°30'
H128. Ground to bottom of front bumper guard.	10.3	10.3	10.3
H129. Ground to bottom of rear bumper guard.	NO GUARDS		
H133a. Bottom of front door to ground, min. dimension - car loaded.	11.2	11.2	11.2
H135a. Bottom of rear door to ground, min. dimension - car loaded.	11.0	11.0	10.9
HD. Min. road clear. (5 pass. load) & loc.	6.04 Frame Siderail 6.04 Fr. Sr. 6.04 Fr. Sr.		
HE. Min. road clearance at rear axle:	6.92 Banjo Housing 6.92 Ban. Hs. 6.92 Ban. Hs.		
HG. Hood at rr. to grd.-vert. dim. excl. molding, fr. hood opening line at cowl (curb wt.)	41.3	41.3	41.3
HH. Max. ht., fr. grd. frt. of windshield (curb wt.)	43.1	43.1	43.1
HJ. Max. ht. fr. grd. back of r. window (curb wt.)	42.9	42.9	42.9

* See Notes, page 19.

AMA Specifications — Passenger Car

MAKE OF CAR OLDSMOBILE MODEL YEAR 1958 DATE ISSUED _____ REVISED _____
 MODEL _____ 88 S 88 98

BODY—LENGTH DIMENSIONS

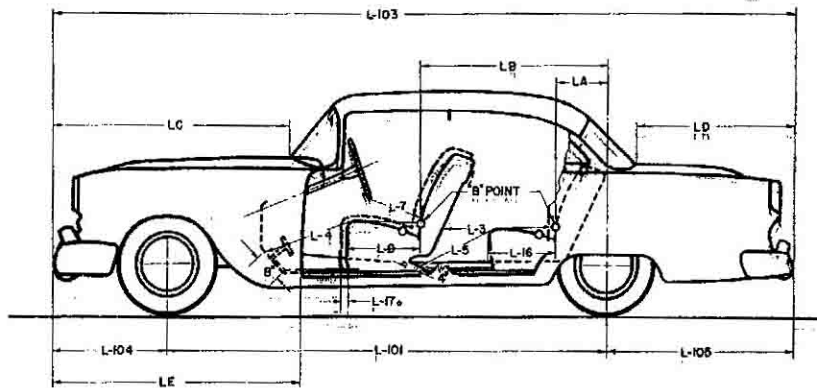

Interior	* L3. Rear compartment of front seat back to rear seat back.	31.2	31.2	31.1
	* L4. Leg room—front—ball of foot to top of seat to seat back—15" line.	44.0	43.8	43.8
	* L5. Leg room—rear—from ball of foot to top of seat cushion and to seat back†	41.2	41.2	41.6
	L7. Steering wheel clearance to seat back taken on arc.	13.9	13.9	13.9
	* L9. Front seat depth (front edge to vert. tan. to seat back on 15" line).	17.8	18.0	18.0
	* L16. Depth of rear seat (front edge to seat back).	18.7	18.7	18.8
	L17a. Total adjustment of front seat at front lower seat frame.	5.3	5.3	5.3
	LA. Rear seat "B" point to center line of rear axle.	16.1	16.1	20.0
	LB. Front seat "B" point to center line of rear axle.	53.6	53.5	57.5
	LC. Front of car to base of windshield.	61.1	61.1	61.1
	LD. Rear of car to base of rear window or upper structure.	43.0	43.0	51.5
LE. Front of car to front edge of front door.	69.7	69.7	69.7	
Exterior	L101. Wheelbase.	122.5	122.5	126.5
	L103. Overall length (bumper to bumper inc. guards).	208.2	208.2	216.7
	L104. Overhang—front including bumper guards.	33.8	33.8	33.8
	L105. Overhang—rear including bumper guards.	51.9	51.9	56.4

* Dimension taken on 15" line—see notes 1 & 2, page 19.

AMA Specifications – Passenger Car

MAKE OF CAR OLDSMOBILE MODEL YEAR 1958 DATE: ISSUED _____ REVISED _____
 MODEL _____ 88 S 88 98

BODY—WIDTH DIMENSIONS

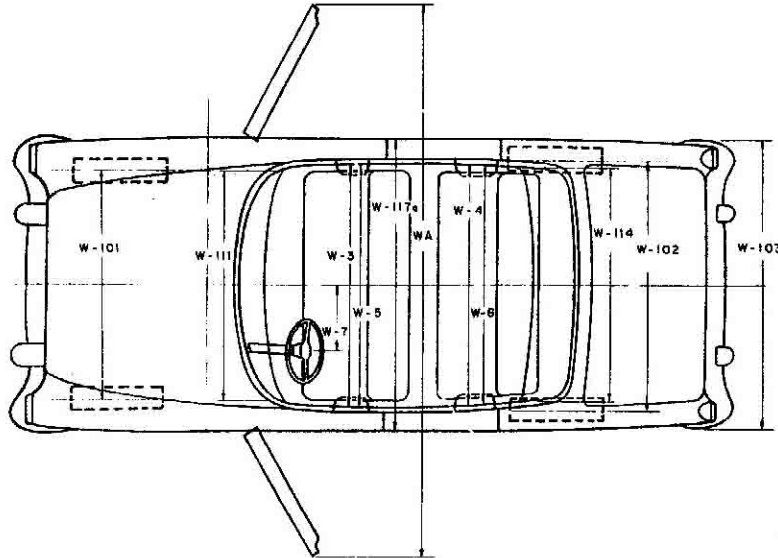

Interior	W3. Front shoulder room, at garnish moulding height or nearest interference 5" forward of seat back.	56.9	56.9	56.9
	W4. Rear shoulder room, at garnish moulding height or nearest interference 5" forward of seat back.	55.7	55.7	55.7
	W5. Front hip room, at top of seat 5" forward of vert. tan. to seat back.	62.5	62.5	62.5
	W6. Rear hip room, at top of seat 5" forward of vert. tan. to seat back.	62.1	62.1	62.1
	W7. Steering wheel center to center of body.	15.3	15.3	15.3
Exterior	W101. Front tread at ground.	59.0	59.0	59.0
	W102. Rear tread at ground.	58.0	58.0	58.0
	W103. Max. overall width of car including bumpers or mouldings.	78.8	78.8	78.8
	WA. Max. overall width of car with doors open.	147.6	147.6	147.6
	W111. Windshield DLO, max. width.	60.8	60.8	60.8
	W114. Back window DLO, max. width.	58.9	58.9	58.9
	W117a. Max. body width at center pillar, less hardware and applied moldings.	74.6	74.6	74.6

AMA Specifications – Passenger Car

MAKE OF CAR OLDSMOBILE MODEL YEAR 1958 DATE ISSUED _____ REVISED _____
 MODEL 88 S88

STATION WAGON—CARGO SPACE DIMENSIONS

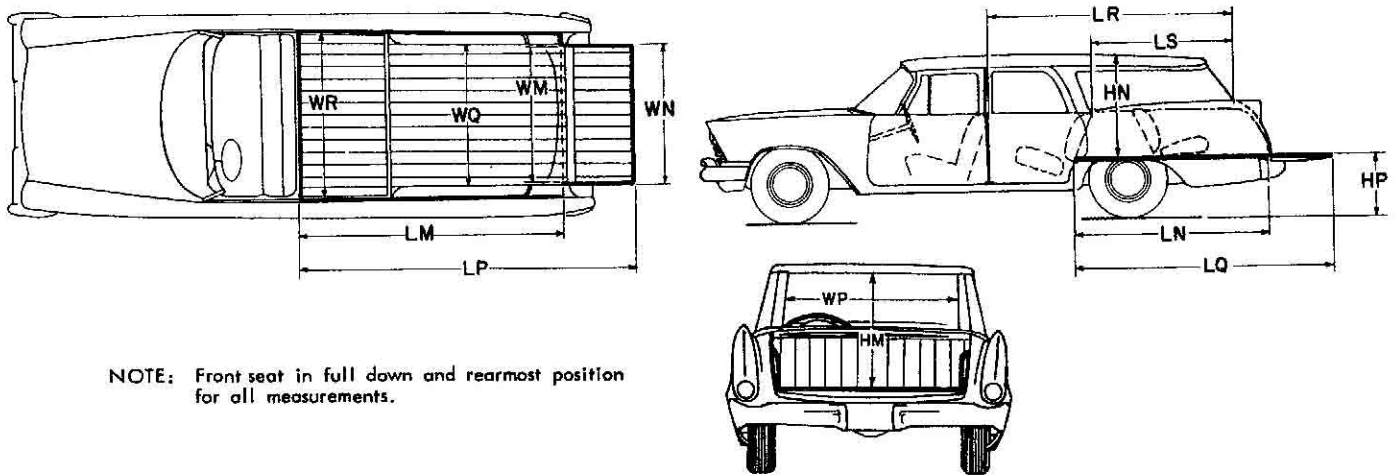

LM Floor length from bottom of front seat to inside of tail gate in raised position.	84.0
LN Floor lgth. from bottom of second seat to inside of tail gate in raised position.	47.2
LP Floor lgth. from bottom of front seat to end of tail gate in lowered position.	96.20
LQ Floor lgth. from bottom of second seat to end of tail gate - tail gate lowered.	65.4
HM Maximum hgth. of rear opening - tail gate lowered.	28.0
WM Rear end opening width at floor.	47.0
WN Rear end opening width at top of tail gate.	47.0
WQ Minimum distance between wheelhouses.	43.4
WP Maximum width of rear opening above raised tail gate.	48.0
WR Maximum width of cargo space at floor.	61.2
LR Cargo horizontal distance from top rear of front seat back to top of tail gate.	72.0
LS Cargo horizontal distance from top rear of second seat back to top of tail gate.	37.8
HN Maximum height of roof above floor at center line of car.	31.4
HP Platform height of end of lowered tail gate - curb weight.	29.0
Third Seat - facing direction.	N. A.

