

# AMA Specifications – Passenger Car

The information contained herein is prepared, distributed by, and is solely the responsibility of the automobile manufacturing company to whose products it relates. Questions concerning these specifications should be directed to the manufacturer whose address is shown below. This uniform specification form was developed by the automobile manufacturing companies under the auspices of the Automobile Manufacturers Association.

MANUFACTURER Chevrolet Motor Division General Motors Corporation	CAR NAME CHEVROLET	
	Std. 230 Cu. In. L-6 283 Cu. In. V-8	
MAILING ADDRESS:	MODEL YEAR	ISSUED: 9-23-63
	1964	REVISED (e): 12-2-63

**NOTES:**

1. The Specifications herein are those in effect at date of compilation and are subject to change without notice by the manufacturer.
2. UNLESS OTHERWISE INDICATED:
  - a. Specifications apply to standard models without optional equipment. Significant deviations are noted.
  - b. Nominal design dimensions are used throughout these specifications.

## TABLE OF CONTENTS

General Specifications . . . . . 1	Drive Units . . . . . 15	Rear Suspension . . . . . 21	Body & Car - General . . . . . 22
Engine - Mechanical . . . . . 2	Brakes . . . . . 18	Body Dimensions . . . . . 22	Weights . . . . . 33
Electrical . . . . . 10	Front Suspension & Steering . . . 19	Station Wagon . . . . . 31	Index . . . . . 37

<b>BODY—TYPES AND STYLE NAMES—</b>		Body type, number of passenger & style names; use manufacturer's code for series & body style.
<u>Std. 230 Cu. In. L-6</u>		
1190-1300-1500-1700		
<u>283 Cu. In. V-8</u>		
		283 Cu. In. V-8
Biscayne	1211	2-Door Sedan - 6-Passenger
	1235	4-Door Station Wagon- 6-Passenger
	1269	4-Door Sedan- 6-Passenger
Bel Air	1611	2-Door Sedan- 6-Passenger
	1635	4-Door Station Wagon- 6-Passenger
	1645	4-Door Station Wagon- 9-Passenger
	1669	4-Door Sedan- 6-Passenger
Impala	1835	4-Door Station Wagon- 6-Passenger
	1839	4-Door Sport Sedan- 6-Passenger
	1845	4-Door Station Wagon- 9-Passenger
	1847	2-Door Sport Coupe- 5-Passenger
	1867	2-Door Convertible- 5-Passenger
	1869	4-Door Sedan- 6-Passenger
Impala Super Sport	1447	2-Door Sport Coupe- 4-Passenger
	1467	2-Door Convertible- 4-Passenger

# AMA Specifications — Passenger Car

Page 1

MAKE OF CAR CHEVROLET MODEL YEAR 1964 DATE ISSUED 9-23-63 REVISED (a) 12-2-63

## GENERAL SPECIFICATIONS

(All dimensions in inches unless otherwise indicated)

MODEL	11-12-13-14- 15-16-17-1800	Additional Information Page No.	Std. 230 Cu. In. L-6 1100-1300-1500-1700	283 Cu. In. V-8 1200-1400-1600-1800				
Wheelbase (L101)		23	119.0					
Tread	Front (W101)	22	60.3, Wagons - 61.3					
	Rear (W102)	22	59.3, Wagons - 60.3					
Maximum Overall Dimensions	Length (L103)	23	209.9 (a)					
	Width (W103)	22	78.1					
	Height (H101)	24	Sedans 56.2	Sp. Sedan 54.9	Sp. Coupe 55.1	Convertible 55.8	St. Wagon 56.7	
Transmission (Specify trade name - opt., not available)	Manual	15	Synchromesh: 3-Speed, Standard					
	Overdrive	16	Optional					
	Automatic	16	Powerglide, Optional					
Axle ratio	Manual	17	Sedans & Coupes - 3.08:1 Convertibles - 3.36:1 Station Wagons - 3.55:1		12 & 1600 Sedans - 3.08:1 Balance - 3.36:1			
	Overdrive	17	3.70:1					
	Automatic	17	Same as Manual					
Tire size		18	Wagons - 8.00 x 14; Convertibles - 7.50 x 14; Others - 7.00 x					
Engine	Type, no. cyl., valve arr.	2	In-Line 6 OHV		90° V-8 OHV			
	Fuel system (Carb., other)	8.	Carburetor					
	Bore and stroke	2	3.875 x 3.25		3.875 x 3.00			
	Piston displ., cu.in.	2	230		283			
	Std. compression ratio	2	8.5:1		9.25:1			
	Max. bhp at engine rpm	2	140 @ 4400		195 @ 4800			
	Max. torque at rpm	2	220 @ 1600		285 @ 2400			

(a) 210.8 on station wagon.

# AMA Specifications—Passenger Car

Page 2

MAKE OF CAR	CHEVROLET	MODEL YEAR	1964	DATE ISSUED	9-23-63	REVISED (a)
MODEL	230 Cu. In. L-6			283 Cu. In. V-8		
	1100-1300-1500-1700			1200-1400-1600-1800		

## ENGINE—GENERAL

Type, no. cyis., valve arr.	In-line 6- OHV	90° OHV V-8
Bore and stroke (nominal)	3.875 x 3.25	3.875 x 3.00
Piston displacement, cu. in.	230	283
Bore spacing (C/L to C/L)	4.4	4.4
No. system: (front to rear)	L. Bank	1-2-3-4-5-6 (In-line)
	R. Bank	1-3-5-7
Firing order	1-5-3-6-2-4	2-4-6-8
Compres. ratio (nominal)	8.5:1	9.25:1
Cylinder Head Material	Cast Alloy Iron	
Cylinder Block Material	Cast Alloy Iron	
Cylinder Sleeves—Wet, dry, none	None	
Number of mounting points	Front	Two
	Rear	One
Engine installation angle	5° 11' - (3-Speed); 5° - (Powerglide & Overdrive)	
Taxable horsepower <small>Diag. 2 x No. Cyl. 2.3</small>	36.0	48.0
Published max. bhp* @ eng. RPM	140 @ 4400	195 @ 4800
Published max. torque* (lb. ft. @ RPM)	220 @ 1600	285 @ 2400
Recommended fuel regular - premium	Regular	
Idle speed (spec. neutral or drive)	Manual	500 in Neutral
	Automatic	475 in Drive

## ENGINE—PISTONS

Material	Cast Aluminum Alloy		
Description and finish	Flat, notched head; Slipper skirt		
Weight (piston only) oz.	20.40	20.30	
Clearance (limits)	Top land	.035-.044	
	Skirt	Top	.0005-.0011 (a)
		Bottom	
Ring groove depth	No. 1 ring	.2153-.2218	
	No. 2 ring	.2153-.2218	
	No. 3 ring	.2093-.2158	
	No. 4 ring	None	

\* Max. bhp (brake horsepower) and max. torque corrected as defined by SAE Engine Test Code.

(a) - Measured at 2.44 from top of piston.

# AMA Specifications – Passenger Car

MAKE OF CAR CHEVROLET MODEL YEAR 1964 DATE ISSUED 9-23-63 REVISED(e) \_\_\_\_\_

## POWER TEAMS

(Indicate whether standard or optional)

MODEL AVAILABILITY	ENGINE					TRANSMISSION	AXLE RATIO # (Std. first)		
	Displ. cu. in.	Carburetor	Compr. Ratio	BHP @ RPM	Torque @ RPM		"A"	"B"	"C"
1100-1300 1500-1700	230	1-Bbl. Down- draft	8.5:1	140 @ 4400	220 @ 1600	<u>3-Speed</u>  Coupes & Sedans Convertibles Station Wagons	3.08:1 3.36:1 3.55:1	3.55:1 3.55:1 --	3.36:1 -- --
						<u>Powerglide*</u> Coupes & Sedans Convertibles Station Wagons	3.08:1 3.36:1 3.55:1	3.55:1 3.55:1 --	3.36:1 -- --
						<u>Overdrive*</u> All models	3.70:1	--	--
1200-1600 (excluding Station Wagons)	283	2-Bbl. Down- draft	9.25:1	195 @ 4800	285 @ 2400	<u>3-Speed</u>  <u>Powerglide*</u>  <u>Overdrive*</u>	3.08:1 3.08:1 3.70:1	3.55:1 3.55:1 --	3.36:1 3.36:1 --
1400-1800 (and all Station Wagons)	283	2-Bbl. Down- draft	9.25:1	195 @ 4800	285 @ 2400	<u>3-Speed</u>  <u>Powerglide*</u>  <u>Overdrive*</u>	3.36:1 3.36:1 3.70:1	3.55:1 3.55:1 --	-- -- --
<p>* - Optional                      "A" - General Purpose (Standard)                      "B" - Special Purpose or Mountain (Optional)                      "C" - Performance (Optional)                      # - Positraction Axle Ratios available in combinations as shown.</p>									

# AMA Specifications – Passenger Car

MAKE OF CAR	CHEVROLET	MODEL YEAR	1964	DATE ISSUED	9-23-63	REVISED (e)
MODEL	230 Cu. In. L-6			283 Cu. In. V-8		
	1100-1300-1500-1700			1200-1400-1600-1800		

## ENGINE—RINGS

Function (top to bottom)	No. 1, oil or comp.	Compression
	No. 2, oil or comp.	Compression
	No. 3, oil or comp.	Oil
	No. 4, oil or comp.	None
Compression	Description - material, type, coating, etc.	Cast alloy iron, inside bevel Upper - Flash chrome plate Lower - Wear resistant coating
	Width	.0775-.0780 Upper; .0770-.0780 Lower
	Gap	.010-.020
Oil	Description - material, type, coating, etc.	Multi-piece (2 rails and one spacer expander) Spacer expander - Steel Rails - Stainless steel, chrome plated O. D.
	Width	.1840 - .1880 (assembled)
	Gap	.015 - .055
Expanders		In oil ring assembly

## ENGINE—PISTON PINS

Material	Chromium steel		
Length	2.990-3.010		
Diameter	.9270-.9273		
Type	Locked in rod, in piston, floating, etc.	Locked in rod	
	Bushing	In rod or piston	None
		Material	-
Clearance	In piston	.00015 - .00025	
	In rod	None	
Direction & amount offset in piston	Major thrust side .060		

## ENGINE—CONNECTING RODS

Material	Drop Forged Steel	
Weight (oz.)	20.80	20.00
Length (center to center)	5.699 - 5.701	
Bearing	Material & Type	Steel backed babbitt or Copper lead alloy
	Overall length	.807
	Clearance (limits)	.0007-.0027
	End play	.009 - .013

# AMA Specifications—Passenger Car

**MAKE OF CAR** CHEVROLET **MODEL YEAR** 1964 **DATE ISSUED** 9-23-63 **REVISED** (\*)12-2-63

<b>MODEL</b>	230 Cu. In. L-6 1100-1300-1500-1700	283 Cu. In. V-8 1200-1400-1600-1800
--------------	--	--

## ENGINE—CRANKSHAFT

Material	Cast nodular iron	Cast nodular iron or forged steel	
Vibration damper type	Rubber mounted inertia	None	
End thrust taken by bearing (No.)	7	5	
Crankshaft end play	.002 - .006		
Main bearing	Material & type		
	Steel-backed babbitt or Copper lead alloy		
	Clearance		
	.0003-.0029		
	Journal dia. and bearing overall length	No. 1	2.3004-.752
		No. 2	2.3004-.752
		No. 3	2.3004-.752
		No. 4	2.3004-.752
No. 5		2.3004-.752	
No. 6		2.3004-.752	
No. 7		2.3004-.760	
Dir. & amt. cyl. offset	None		
Crank pin journal diameter	1.999-2.000		

## ENGINE—CAMSHAFT

Location	Above & to right of crankshaft	In block above crankshaft
Material	Cast alloy iron	
Bearings	Material	
	Steel-backed babbitt	
	Number	4
		5
Type of Drive	Gear or chain	
	Gear	
	Chain	
	Chain	
	Crankshaft gear or sprocket material	
	Steel	
Steel sprocket		
Camshaft gear or sprocket material		
Bakelite and fabric composition with steel hub		
Cast alloy iron		
Timing chain	No. of links	None
	Width	None
	Pitch	None
		46
		.875
		.500

## ENGINE—VALVE SYSTEM

Hydraulic lifters (Std, opt, NA)	Standard	
Valve rotator, type (intake, exhaust)	None	
Rocker ratio	1.75:1	1.5:1
Operating tappet clearance (indicate hot or cold)	Intake	Zero
	Exhaust	Zero
Timing marks on flywheel, damper, other	Harmonic Balancer	Crankshaft Pulley Hub

(Continued)

# AMA Specifications—Passenger Car

MAKE OF CAR **CHEVROLET** MODEL YEAR **1964** DATE ISSUED **9-23-63** REVISED **(\*)**

	230 Cu. In. L-6	283 Cu. In. V-8
<b>MODEL</b>	1100-1300-1500-1700	1200-1400-1600-1800

## ENGINE—VALVE SYSTEM (cont.)

<b>Timing *</b>	<b>Intake</b>	Opens (°BTC)	34°		32° 30'	
		Closes (°ABC)	86°		87° 30'	
		Duration - deg.	300°		300°	
	<b>Exhaust</b>	Opens (°BBC)	68°		74° 30'	
		Closes (°ATC)	52°		45° 30'	
		Duration - deg.	300°		300°	
<b>Valve opening overlap</b>		86°		78°		
<b>Intake</b>	<b>Material</b>		Carbon Steel			
	<b>Overall length</b>		4.902 - 4.922			
	<b>Actual overall head dia.</b>		1.715 - 1.725			
	<b>Angle of seat &amp; face</b>		46° (seat) - 45° (face)			
	<b>Seat insert material</b>		None			
	<b>Stem diameter</b>		.3404 - .3417			
	<b>Stem to guide clearance</b>		.0010 - .0033			
	<b>Lift (@ zero lash)</b>		.3350		.3987	
	<b>Outer spring press. and length</b>	<b>Valve closed (lb. @ in.)</b>	84-92 @ 1.66		78-86 @ 1.66	
		<b>Valve open (lb. @ in.)</b>	166-176 @ 1.33		170-180 @ 1.26	
	<b>Inner spring press. and length</b>	<b>Valve closed (lb. @ in.)</b>	None		Spring Damper	
		<b>Valve open (lb. @ in.)</b>	None		Spring Damper	
	<b>Exhaust</b>	<b>Material</b>		High Alloy Steel		
		<b>Overall length</b>		4.913 - 4.933		
<b>Actual overall head dia.</b>		1.495 - 1.505				
<b>Angle of seat &amp; face</b>		46° (seat) - 45° (face)				
<b>Seat insert material</b>		None				
<b>Stem diameter</b>		.3410 - .3417				
<b>Stem to guide clearance</b>		.0010 - .0027				
<b>Lift (@ zero lash)</b>		.3350		.3987		
<b>Outer spring press. and length</b>		<b>Valve closed (lb. @ in.)</b>	84-92 @ 1.66		78-86 @ 1.66	
		<b>Valve open (lb. @ in.)</b>	166-176 @ 1.33		170-180 @ 1.26	
<b>Inner spring press. and length</b>		<b>Valve closed (lb. @ in.)</b>	None		Spring Damper	
		<b>Valve open (lb. @ in.)</b>	None		Spring Damper	

## ENGINE—LUBRICATION SYSTEM

<b>Type of lubrication (splash, pressure, nozzle)</b>	<b>Main bearings</b>	<b>Pressure</b>
	<b>Connecting rods</b>	<b>Pressure</b>
	<b>Piston pins</b>	<b>Splash</b>
	<b>Camshaft bearings</b>	<b>Pressure</b>
	<b>Tappets</b>	<b>Pressure</b>
	<b>Timing gear or chain</b>	<b>Nozzle</b>
	<b>Cylinder walls</b>	<b>Conn. Rod-Bearing Throw Off Pressure, Jet Cross Sprayed</b>

\* - Including Ramps

(Continued)

# AMA Specifications – Passenger Car

MAKE OF CAR	CHEVROLET	MODEL YEAR	1964
		DATE ISSUED	9-23-63
		REVISED (a)	
MODEL	230 Cu. In. L-6	283 Cu. In. V-8	
	1100-1300-1500-1700	1200-1400-1600-1800	

## ENGINE—LUBRICATION SYSTEM (cont.)

Oil pump type	Gear	
Normal oil pressure (lb. @ engine rpm)	30-45 PSI @ 1500 RPM	
Oil pressure sending unit (elect. or mech.)	Electric	
Type oil intake (floating, stationary)	Stationary	
Oil filter system (full flow, partial, other)	Full Flow	
Filter replacement (element, complete)	Complete	Element
Capacity of crankcase, less filter-refill (qt.)	4.0	
Oil grade recommended (SAE viscosity and temperature range)	32° F and above -----	SAE 20W, SAE 20, SAE 10W
	0° F and above -----	SAE 10W, SAE 10W-30
	Below 0° F -----	SAE 5W, SAE 5W-20
Engine Service Requirement (MM, MS, etc.)	MS or DG	

## ENGINE—EXHAUST SYSTEM

Type (single, single with cross-over, dual, other)	Single	Single with crossover
Muffler No. & type (reverse flow, straight thru, separate resonator)	One; Reverse Flow	
Exhaust pipe dia. (O.D.) wall thickness	Branch	2.00 x .067 - .083
	Main	2.00 x .057 - .069
Tail pipe diameter (O.D. & wall thickness)	1.875 x .062 - .076	

## ENGINE—CRANKCASE VENTILATION SYSTEM

Type (ventilates to atmos., induction system, other)	Standard Optional	Ventilates to Induction System
Control unit	Make and model	
	Location	Top rear of rocker cover   At rear of carburetor
	Energy source (manifold vacuum, carburetor air stream, other)	Manifold Vacuum
Complete system	Control method (variable orifice, fixed orifice, other)	Variable
	Discharges (to intake manifold, carb. air intake, air cleaner intake, other)	Intake Manifold
	Air Inlet (breather carburetor air stream, other)	Breather Carb
		Check

# AMA Specifications— Passenger Car

MAKE OF CAR CHEVROLET MODEL YEAR 1964 DATE ISSUED 9-23-63 REVISED (\*) 12-2-63

	230 Cu. In. L-6 1100-1300-1500-1700	283 Cu. In. V-8 1200-1400-1600-1800
--	--	--

## ENGINE—FUEL SYSTEM

(See Supplement to Page 8 for Details of Fuel Injection, Supercharger, etc. if used)

Induction type: Carburetor, fuel injection, supercharger.		Carburetor	
Fuel Tank	Capacity (gals.)	20 (19 on Station Wagons)	
	Filler location	Left rear quarter panel	
Fuel Pump	Type (elec. or mech.)	Mechanical	
	Locations	Lower right front of engine	
	Pressure range	5.00 - 6.50 PSI	5.25 - 6.50 PSI
Vacuum booster (std., optional, none)		None	
Fuel Filter	Type	Fine mesh plastic strainer in gasoline tank & sintered bronze filter in carburetor	
	Locations		
Carburetor	Choke type	Automatic	
	Intake manifold heat control (exhaust or water)	Exhaust	
	Air filter type	Standard Oil wetted polyurethane	Paper element
	Optional Oil Bath Type		—

## CARBURETOR SUPPLEMENTARY INFORMATION

Model Usage	Engine Displ.	Transmission	Carburetor		No. Used and Type	Barrel Size
			Make	Model		
1100-1300 1500-1700	230	Synchronesh Powerglide	Rochester	7023003	One; Single Barrel, Down- draft	1.56
			Rochester	7023000		
1200-1400 1600-1800	283	Synchronesh Powerglide	Rochester	7024101	One; Two Barrel Down- draft	1.44
			Rochester	7024106 ●		

# AMA Specifications - Passenger Car

<b>MAKE OF CAR</b> CHEVROLET	<b>MODEL YEAR</b> 1964	<b>DATE ISSUED</b> 9-23-63 <b>REVISED</b> (e)
<b>MODEL</b>	230 Cu. In. L-6	283 Cu. In. V-8
	1100-1300-1500-1700	1200-1400-1600-1800

## ENGINE-COOLING SYSTEM

Type system (pressure, pressure vented, atmospheric, other)		Pressure	
Radiator cap relief valve pressure		13 PSI ± 1	
Circulation thermostat	Type (choke, bypass)	Choke	
	Starts to open at (°F)	177° - 183° F	
Water pump	Type (centrifugal, other)	Centrifugal	
	GPM @ 1000 pump rpm	60 GPM @ 4400 RPM*	53 GPM @ 4200 RPM*
	Number of pumps	One	
	Drive (V-belt, other)	V-Belt	
Bearing type		Permanently lubricated double roll ball	
By-pass recirculation type (internal, external)		Internal	
Radiator core type (cellular, tube and fin, other)		Tube on center	
Cooling system capacity	With heater (qt.)	12	17
	Without heater (qt.)	11	16
	Opt. equipment-specify (qt.)	12	18
Water jackets full length of cylinder (yes, no)		Yes	
Water all around cylinder (yes, no)		Yes	
Radiator hose	Lower	Number and type (molded, straight)	One, molded
		Inside diameter	1.75
	Upper	Number and type (molded, straight)	One, molded
		Inside diameter	1.50
	By-pass	Number and type (molded, straight)	None
		Inside diameter	- - -
Fan	Number of blades & Spacing		4, Staggered
	Diameter		17.62
	Ratio-fan to crankshaft rev.		.949:1
	Fan cutout type	None	5-blade 18" fan used with air/cc
	Bearing type		Double Row Ball
*Drive belts (Indicate belt used by letter)	Fan	A	D
	Generator	A	D
	Water Pump	A	D
	Power Steering	B	E
	Air Conditioning	C	F

* Drive Belt Dimensions	A	B	C	D	E	F
Angle of V	38° - 42°					
Nominal length (SAE)	39.00	49.50	54.75	53.25	41.50	57.50
Width	.380 ± .005					

\* - Actual flow through the engine.

# AMA Specifications – Passenger Car

<b>MAKE OF CAR:</b> CHEVROLET	<b>MODEL YEAR:</b> 1964	<b>DATE ISSUED:</b> 9-23-63	<b>REVISED:</b> (e)
<b>MODEL:</b>	230 Cu. In. L-6	283 Cu. In. V-8	
	1100-1300-1500-1700	1200-1400-1600-1800	

## ELECTRICAL—SUPPLY SYSTEM

<b>Battery</b>	Make and Model	Delco #1983504		
	Voltage Rtg. & Total Plates	12 Volt, 54 Plate		
	SAE Designation & Amp Hr. Rtg	44 Amp/Hr. @20 Hr. Rate		
	Location	Right front engine compartment		
	Terminal grounded	Negative		
<b>Generator</b>	Make	Delco-Remy		
	Model	#1100668		
	Type	Diode rectified		
	Ratio—Gen. to Cr/s rev.	2.46:1		
	Gen. cut-in (hot)—engine rpm			
<b>Regulator</b>	Make	Delco-Remy		
	Model	#1119515		
	Type	Vibrator		
	Cutout relay	Closing voltage @ generator rpm	None	
		Reverse current to open		
	Regulated	Voltage	13.8 - 14.8 @ 85° F	
		Current		
	Voltage test conditions	Temperature	Operating	
Load		3-8 Amperes		
Other		None		

## ELECTRICAL—STARTING SYSTEM

<b>Starting motor</b>	Make	Delco-Remy		
	Model	#1107259	#1107247	
	Rotation (drive end view)	Clockwise		
	Engine cranking speed			
	Test conditions	Engine at Operating Temperature		
	Lock test	Amps		
		Volts		
		Torque (lb. ft.)		
No load test	Amps	49-76		
	Volts	10.6		
	RPM (min.)	6200-9400		
<b>Motor control</b>	Switch (solenoid, manual)	Solenoid		
	Starting procedure	<p><b>SYNCHROMESH</b> - Place gearshift in neutral and depress clutch to floor.</p> <p><b>POWERGLIDE</b> - Place control lever in N or P position.</p> <p><b>INITIAL START</b> - Press accelerator pedal to floor once to set automatic choke, then release. Turn ignition to <b>START</b> &amp; release as soon as engine starts.</p>		

(Continued)

# AMA Specifications – Passenger Car

**MAKE OF CAR** CHEVROLET **MODEL YEAR** 1964 **DATE ISSUED** 9-23-63 **REVISED** (\*)12-2

	230 Cu. In. L-6	283 Cu. In. V-8
<b>MODEL</b>	1100-1300-1500-1700	1200-1400-1600-1800

## ELECTRICAL—STARTING SYSTEM (cont.)

<b>Motor Drive</b>	Engagement type		Positive Shift Solenoid	
	Pinion meshes (front, rear)		Rear	
	Number of teeth	Pinion	9	
		Flywheel	153	
	Flywheel tooth face width		.4070	

## ELECTRICAL—IGNITION SYSTEM

<b>Coil</b>	Make		Delco-Remy		
	Model		#1115184	#1115115	
	Amps	Engine stopped		4.0	
Engine idling		1.8			
<b>Distributor</b>	Make		Delco-Remy		
	Model		#1110280	#1111015	
	Cent'gal adv. in crankshaft degrees @ engine rpm (nominal)	Start (rpm)		800	
		Intermediate points deg. @ rpm			
		Max deg. @ rpm		30° @ 3000	30° @ 4000
	Vacuum adv. in crankshaft degrees @ in. Hg. (nominal)	Start (in Hg.)		6	8
		Intermediate points, deg @ in Hg			
		Max. deg. in. Hg.		● 21 @ 14.5	15 @ 15.5
	Breaker gap (in.)		.019		
	Cam angle (deg.)		31° - 34°	28° - 32°	
Breaker arm tension (oz.)		19 - 23 oz.			
<b>Timing</b>	Crankshaft deg. @ rpm.		4° ± BTC @ 450-500	3° - 5° BTC @ 550	
	Mark location		Harmonic Balancer		
	Cylinder numbering system (see page 2)		Front to Rear 1-2-3-4-5-6	Crankshaft Pulley Hw Left Bank 1-3-5-7 Right Bank 2-4-6-8	
	Firing order (see page 2)		1-5-3-6-2-4      1-8-4-3-6-5-7-2		
<b>Spark Plug</b>	Make and model		AC 46N (Long reach)      AC 45		
	Thread (mm)		14		
	Tightening torque (lb. ft.)		25		
	Gap		.033 - .038		
<b>Cable</b>	Conductor type				
	Linen core impregnated with electrical conducting material				
	Rubber with Neoprene jacket				
Insulation type					
Neoprene					
Spark plug protector					

## ELECTRICAL—SUPPRESSION

Locations & type	Non-metallic high tension ignition cables
------------------	---

# AMA Specifications – Passenger Car

MAKE OF CAR CHEVROLET MODEL YEAR 1964 DATE ISSUED 9-23-63 REVISED (a) 12-2-63 ●

MODEL 11-1800  
 230 In.<sup>3</sup> L-6  
 283 In.<sup>3</sup> V-8

## ELECTRICAL—INSTRUMENTS AND SWITCHES

Speed-ometer	Make	AC
	Trip odometer (yes, no)	NO
Charge indicator—type		Tell-tale lamp
Temperature indicator—type		Tell - tale lamps (cold, green; hot, red)
Oil pressure indicator—type		Tell-tale lamp
Fuel indicator—type		Electric, gauge
Other		Parking brake flasher (a)
Ignition switch	Identify positions in order and circuits controlled	2nd position CCW from vertical - ACC (accessories) 1st position CCW from vertical - LOCK (off, locked) Vertical - OFF (Unlocked) 1st position CW from vertical - ON (ignition, batt., access.) 2nd position CW from vertical - START (ignition, batt., accessories, starter: spring return to ON)
	Provision for illumination	1445 Lamp
	Location	Instru. panel to right of steering column
Main light- ing switch	Identify positions and lamps controlled	Fully depressed - off 1st notch - Instru. panel, parking, tail and license lamps 2nd notch - Instru. panel, head, tail and license lamps CW rotation of knob - dim and turn off instru. panel lamps CCW rotation of knob - turn on and brighten instru. panel lamps; Full CCW rotation - turn on dome lamp and/or courtesy lamps ●
Other light switches	Locations and lamps controlled	Toe panel - Head lamp dimmer Glove compartment - Glove comp. lamp (b) Front door hinge pillar - Dome and courtesy lamps (c) Steering column - Turn signal lamps Under instru. panel - Stop lamps Steering mast jacket - Back-up lamps (a) Console compartment - Console compartment light (d)
Other switches	Locations and devices controlled	Accelerator linkage - Overdrive kick-down (e) Instru. panel to right of steering column - Heater blower Doors or qtr. trim panels - Power windows (e) Instru. panel, center - Radio (e) Instru. panel, left of steering column - W/S wiper Instru. panel, left of steering column - Tailgate window (h) Steering column - Trans. Neu. S&L Sw. (e) Front seat lower panel, L.H. side - Power seat (j) Under instru. panel to left of steering column - Power top (k) ● Instru. panel, left of strng column - CRUISE CONTROL
Windshield wiper	Make	Delco
	Type	Electric, Single-speed (f)
	Vacuum booster provision	None
	Washer provision	None (g)
Horn	Type	Vibrator
	Number used	2
	Amp draw (each)	8.00-11.0 @ 12.5 V

- (a) Std. on 13, 14, 17 and 1800 (g) Optional dealer installed access.  
 (b) Std. on 13, 14, 15, 16, 17 and 1800 (h) Standard on 15, 16, 17 and 1845  
 (c) Std. on 13 thru 1800 except instru. panel courtesy, opt. except convertibles; door jam switches std. except 11 and 1200. (j) Optional on 13, 14, 15, 16, 17 and 1800.  
 (d) Std on 13 and 1400 (k) Standard on 13, 14, 17 and 1867  
 (e) Optional equipment  
 (f) Optional electric two-speed incl. washer

# AMA Specifications – Passenger Car

Page

MAKE OF CAR CHEVROLET MODEL YEAR 1964 DATE ISSUED 9-23-63 REVISED <sup>(\*)</sup>

MODEL 11-1800 L-6 230 IN.<sup>3</sup> ENGINE  
V-8 283 IN.<sup>3</sup> ENGINE

## ELECTRICAL—LAMP BULBS

Give quantity used and trade number, e.g., Headlamp 2-5400 5, dual headlight 2-4001, 2-4002.

Headlamps & arrangement		Dual, Horizontal: Outer, 2-4002; Inner, 2-4001	
Headlamp beam indicator		1-1895	
Parking		2-1157	
Tail		Except Wagons, 2 or 4-1157 (a); Wagons, 2-1157	
Stop		Except Wagons, 2 or 4-1157 (b); Wagons, 2-1157	
Direction signal	Front	2-1157	
	Rear	Except Wagons, 2 or 4-1157; Wagons, 2-1157	
	Indicator	2-1445	
License Plate		1-1155	
Oil pressure indicator		1-1895	
Charge indicator		1-1895	
Instrument		4-1895	
Clock		(Instrument)	
Radio		1-1893	Optional
Indicate also whether the following lamp assemblies are standard equipment, optional, or NA.			
Ignition lock		1-1445	Reg. Prod
Back up		2-1156	(c)
Dome		Roof Center, 1-211; Rear Qtr., 2-90; Side Rail 2-90;	Reg. Prod
Glove compartment		Instr. Panel, 1-1895 (d); Seat Separator, 1-1816	Reg. Prod
Prkg. brake signal		1-257	(c)
Luggage compartment		(Except Wagons) 1-1003 Except when DIA 1-93	(c)
Underhood		1-93	
Courtesy		Instru. Panel, 2-631 (e); Rear Qtr., 1-90 Reg. Prod; Seat Sep., 1-211 R	
Ash Tray		1-1445	Opt. (P)
Spot Lamps		Inside Operated, 1-4405; Portable, 1-4416	Optional
Traffic Hazard Indicator		1-1445	Optional
Compass		1-53	Optional
Tachometer		1-53	Optional

- (a) Two "tail only" on 15-1600 (inboard lamps); trade No. 1155.  
(b) Two on 11-1200, and 15-1600; four on 13-1400, and 17-1800.  
(c) Optional for 11-1200, and 15-1600.  
(d) Optional for 11-1200.  
(e) Optional except convertible.

### Regular Production Items Continued

Heater Controls	1-1895
Fuel Gage	1-1895
Temp. Indicators	2-1895
Auto. Trans. Dial Indicator	1-1445

# AMA Specifications – Passenger Car

MAKE OF CAR CHEVROLET MODEL YEAR 1964 DATE ISSUED 9-23-63 REVISED (•) 12-2-63

MODEL 11-1800  
 230 in.<sup>3</sup> L-6  
 283 in.<sup>3</sup> V-8

## ELECTRICAL—FUSE & CIRCUIT BREAKER DATA

Fuses in Fuse Panel unless otherwise indicated

Use trade number of fuse, e.g., SFE-10. Indicate circuit breaker by ampere capacity suffixed by letters "C.B.", e.g., 30 C.B. Where fuse or circuit breaker protects multiple circuits indicate first use by a letter and repeat the same letter for all units protected by the same fuse or circuit breaker, e.g., Parking lamp SFE-10 (a), Direction indicator same as (a).

Headlamp	15 C. B.	(a)	Courtesy Lamps	-
Headlamp beam indicator		(a)	Instr. Panel	(b)
Parking lamp		(a)	Seat Separator	(b)
Tail lamp	AGC 15	(b)	Rear Qtr.	(b)
Stop lamp		(b)	Additional Dome Lamps	-
Direction indicator	AGC 3	(c)	Rear Qtr.	(b)
License plate lamp		(b)	Side Rail	(b)
Instrument lamp		(c)	Heater	AGC 10; IF A. C.
Ignition lamp		(c)		AGC 30 (f)
Back up lamp	AGC 10	(d)	Spotlamp	
Dome lamp		(b)	Inside Operated	AGC 15 (in line)
Clock		(b)	Portable	(b)
Clock lamp	(Instrument lamp)		Underhood Lamp	SAE 4 (in line)
Radio	AGC 2.5	(g)	Traffic Hazard Indicator	(b)
Glove compartment lamp		(b)	Compass Lamp	(c)
Lugg. Compt. Lamp		(b)	Air Conditioning	
Park. Brake Alarm		(d)	Blower Motor	AGC 30 (in line)
Heater Controls Lamp		(c)	Circuit	AGC 30 (f)
Fuel Gage Lamp		(c)	Defogging Unit	AGC 5 (d)
W/S Wiper (Single Speed)	SAE 20	(e)	W/S Wiper (Two-Speed)	14 C. B. (switch)
Fuel Gage		(d)		(e)
Cig. Lighter		(b)	Tachometer	
Oil, Temp. & Gen. Indicators		(d)	Lamp	(c)
Auto. Trans. Ind. Dial		(c)	Circuit	(d)
Ash Tray Lamp		(c)	Cruise Control	(d) •

## ELECTRICAL—LOCATION OF OUTSIDE LAMPS

		Sedans	Coupes	Convertible	Wagon	
Height above ground to center of bulb	Tail	Lowest	23.4	23.7	22.7	
		Highest	23.4	23.7	22.7	
	Stop	23.4	23.7	22.7		
	Backup	23.4	23.7	22.7		
	License, rear	19.3	19.6	17.1		
	Directional	Front	16.9	17.2	17.5	
		Rear	23.4	23.7	22.7	
	Headlamp	Inside	27.6	27.6	27.9	
		Outside*	27.6	27.6	27.9	
	Distance from C/L of car to center of bulb	Tail	Inside	17.3 Impala, 23.9 Biscayne, Bel Air		
Outside			30.6		32.1	
Stop		17.3 Impala, 23.9 Biscayne, Bel Air				
Backup		23.9				
License, rear		On Centerline				
Directional		Front	27.4			
		Rear	17.3 Impala, 23.9 Biscayne, Bel Air			
Headlamp		Inside	23.5			
		Outside*	63.2			

\* If single headlamps are used enter here.

# AMA Specifications – Passenger Car

Page 14 A

MAKE OF CAR CHEVROLET MODEL YEAR 1964 DATE ISSUED 9-23-63 REVISED (a)

## SUPPLEMENTARY INFORMATION

MODEL 230 Cu. In. L-6, 1100-1300-1500-1700; 283 Cu. In. V-8, 1200-1400-1600-1800

Power Seats - - - - - 40 C. B.  
Power Windows - - - - - 40 C. B.  
Folding Top Motor - - - - - 40 C. B.  
Tailgate Motor - - - - - 40 C. B.  
Overdrive Solenoid AGC 15 - - In Line

# AMA Specifications – Passenger Car

MAKE OF CAR CHEVROLET MODEL YEAR 1964 DATE ISSUED 9-23-63 REVISED (a) 12-2-6

MODEL 11-1800 L-6 230 In.<sup>3</sup> Engine V-8 283 In.<sup>3</sup> Engine

## DRIVE UNITS—CLUTCH (Manual Transmission)

Make & type		Chevrolet, Single Dry Disk
Type pressure plate springs		Diaphragm
Effective plate pressure (lb.)		Reg. Prod. -15-1800; HD-19-2200 1700-1950 •
No. of clutch driven discs		One with two friction surfaces
Clutch facing	Material	Woven asbestos except HD clutch-front woven, rear molded
	Outside & inside dia.	Reg. Prod. -9.12, 6.12; HD 10.0, 6.0 10.0, 6.5
	Total eff. area (sq.in.)	Reg. Prod. -71.8; HD-100.5 90.7
	Thickness	.135 ea., unloaded
Engagement cushioning method		Flat spring steel between facings
Release bearing	Type & method of lubrication	Single row ball, packed and sealed
Torsional damping	Methods: springs, friction material	Coil Springs

## DRIVE UNITS—TRANSMISSIONS

Manual (std. or opt.)	3-Speed Standard
Manual with overdrive (std. or opt.)	Optional
Automatic (std. or opt.)	Optional

## DRIVE UNITS—MANUAL TRANSMISSION

Number of forward speeds		3	
Transmission ratios	In first	2.94	
	In second	1.68	
	In third	1.0	
	In fourth	--	
	In reverse	2.94	
Synchronous meshing, specify gears		2nd and 3rd	
Shift lever location		Steering Column	
Lubricant	Capacity (pt.)	3	
	Type recommended	Meeting Military Specification Mil-L-2105-B	
	SAE viscosity number	Summer	SAE 80
		Winter	SAE 80
Extreme cold		SAE 80	

# AMA Specifications – Passenger Car

MAKE OF CAR CHEVROLET MODEL YEAR 1964 DATE ISSUED 9-23-63 REVISED (e) 12-2-63

MODEL 11-1800 L-6 230 IN.<sup>3</sup> ENGINE V-8 283 IN.<sup>3</sup> ENGINE

## DRIVE UNITS—MANUAL TRANSMISSION WITH OVERDRIVE

For transmission data see manual transmission section

Overdrive	Type (planetary or other)		Planetary
	Manual lockout (yes, no)		Yes
	Downshift accelerator control (yes, no)		Yes
	Minimum cut-in speed		Output Shaft RPM: Acceleration, 1440; Deceleration, 110
Gear ratio		0.7:1	
Lu- bri- cant	Capacity (pt.) (Overdrive only)		1
	Separate filler (yes, no)		No
	Type recommended		Meeting Military Specification Mil-L-2105-B
	SAE vis- cosity number	Summer	SAE 80
		Winter	SAE 80
Ext. cold		SAE 80	

## DRIVE UNITS—AUTOMATIC TRANSMISSION

Trade name		Powerglide	
Type: describe		Torque Converter with Planetary Gears	
Method of Selection (Lever, Push Button or other)		Lever—(Floor mounted on 13-1400 models, steering column mounted for all others)	
Selector Pattern		P-R-N-D-L	
List gear ratios Selector Pattern and indicate which are used in each selector position		D- 1.82:1 and 1:1 L- 1.82:1 R- 1.82:1	
Max. upshift speeds—drive range		54	59
Max. kickdown speeds—drive range		51	56
Torque converter	Number of elements		3
	Max. ratio at stall		2.10
	Type of cooling (air, water)		None
Lubricant	Capacity—refill (pt.)		3
	Type recommended		Type A, Suffix A
Special transmission features			

## DRIVE UNITS—PROPELLER SHAFT

Number used		2	
Type (exposed, torque tube)		Tubular, Exposed	
Outer diameter x length* x wall thickness	Manual transmission		Front 2 x 30.1 x .10 Rear 2 x 35.0 x .10
	Overdrive transmission		Front 2 x 25.0 x .10 Rear 2 x 35.0 x .10
	Automatic transmission		Front 2 x 27.2 x .10 Rear 2 x 35.0 x .10

\*Center to center of universal joints, or to centerline of rear attachment.

(Continued)

# AMA Specifications – Passenger Car

MAKE OF CAR CHEVROLET MODEL YEAR 1964 DATE ISSUED 9-23-63 REVISED (e)  
 MODEL 11-1800 L-6 230 IN.<sup>3</sup> ENGINE V-8 283 IN.<sup>3</sup> ENGINE

### DRIVE UNITS—PROPELLER SHAFT (cont.)

Intermediate bearing	Type (plain, anti-friction)	Single Row Ball, Sealed
	Lubrication (fitting, prepack)	Prepack
Universal joints	Make	Chevrolet
	Number used	3
	Type (ball and trunnion, cross, other)	Cross
	Bearing	Type (plain, anti-friction)
Lubric. (fitting, prepack)		Prepack
Drive taken through (torque tube or arms, springs)		Control arms
Torque taken through (torque tube or arms, springs)		Control arms

### DRIVE UNITS—REAR AXLE

Description (see instructions)		Reg. Production - Semi-Floating, Overhung Pinion Gear		
Limited Slip differential, type		Reg. Production with Dual Disk Clutches		
Drive Pinion Offset		1.5		
No. of differential pinions		Reg. Production - 2; Limited Slip - 4		
Gear ratios (Std. equip.)	Manual transmission	Sedans and Coupes - 3.08:1 Convertibles - 3.36:1 Sta. Wgn. - 3.55:1	1200 and 1600 Sedans - 3.08:1 Balance - 3.36:1	
	Overdrive transmission	3.70:1		
	Automatic transmission	Same as Manual		
Ring gear O.D. (std. ratio)		8.375		
Pinion adjustment (shim, other)		Shim		
Pinion bearing adj. (shim, other)		None		
Wheel bearing type		Single Row Ball, Sealed		
Lubricant	Capacity (pt.)	4		
	Type recommended	Military Specification Mil-L-2105 B		
	SAE viscosity number	Summer	SAE 80	
		Winter	SAE 80	
Extreme cold		SAE 80		

### REAR AXLE RATIO TOOTH COMBINATIONS

(See page 3 for axle ratio usage)

Axle ratio		3.08:1	3.36:1	3.55:1	3.70:1
No. of teeth	Pinion	12	11	9	10
	Ring gear	37		32	37

# AMA Specifications - Passenger Car

MAKE OF CAR CHEVROLET MODEL YEAR 1964 DATE ISSUED 9-23-63 REVISED (\*)12-2-63  
 MODEL 11-1800 L-6 230 IN.<sup>3</sup> ENGINE  
 V-8 283 IN.<sup>3</sup> ENGINE

### DRIVE UNITS—WHEELS

Type & material		Short Spoke Disk, Steel
Rim (size and flange type)	Std.	14 x 5J Except Wagons 14 x 6 JK
	Opt.	14 x 6JK; 15 x 5K
Attachment	Type (bolt or stud)	Stud
	Circle diameter	4.75
	Number and size	5 Hex Nuts, 7/16 - 20 UNF 2B

### DRIVE UNITS—TIRES - Tubeless Unless Otherwise Indicated

Standard (List option below)	Size & ply	7.00 x 14-4PR Except Conv., 7.50 x 14-4PR and Wagons 8.00 x 14-4PR
	Type - Nylon, etc.	Blackwall, Rayon
Rev/mile at 50 mph.		7.00 x 14-817; 7.50 x 14-800; 8.00 x 14-785
Inflation press. (cold)	Front	24
	Rear	24 Except Wagons 28
Optional tires - size and ply		6.70 x 15-4PR (*), Hyway, Nylon, Blackwall, Tube or Tubeless. 6.70 x 15-4PR (*), Hyway, Rayon, Blackwall, Tube or Tubeless. 6.70 x 15-6PR (**), Hyway, Rayon, Blackwall. 6.70 x 15-4PR (*), On-Off, Nylon, Blackwall, Tube. See foot note

### BRAKES—SERVICE

		Regular Production	Metallic
Type (duo-servo, disc, balanced, etc.):		Duo-Servo, 4 Wheel Hydraulic, Reverse Self-Adjusting	
Self adjusting (std., opt., N.A.):		Regular Production	
Hydraulic system type (single, dual, etc.):		Single	
Power brake make & type (remote, integral, etc.):		Bendix or Delco Moraine Vacuum Power Unit Assisting Master Cylinder; Integral	
Effective area (sq. in.)*		186.2	145.2
Gross lining area (sq. in.)**		200.4	145.2
Swept drum area (sq. in.)***		328.0	
Percent brake effectiveness—front		58.5	
Drum	Front	11.0	
	Rear	11.0	
Type and material		Composite; Rim-Cast Iron; Web-Steel	
Wheel cylinder bore	Front	1.1875	
	Rear	1.00	
Master cylinder bore		1.00	.875
Available pedal travel		6.38	
Line pressure at 100 lb. pedal load		750	980
Shoe clearance adjustment		Self-Adjusting	

(Continued)

\* Excludes rivet holes, grooves, chamfers, etc.  
 \*\* Includes rivet holes, grooves, chamfers, etc.  
 \*\*\* Total swept areas for four brakes.  
 Widest lining contact width for each brake x its drum circumference.

- (a) 7.00 x 14-4PR, Hyway, Rayon, Whitewall.  
 7.10 x 15-4PR (\*), Hyway, Rayon, Blackwall; 7.10 x 15-4PR (\*), Hyway, Nylon, Blackwall  
 7.50 x 14-4PR (\*), Hyway, Nylon, Blackwall; 7.50 x 14-4PR (\*), Hyway, Nylon, Whitewall  
 7.50 x 14-4PR, Hyway, Rayon, Whitewall; 7.50 x 14-6PR (\*\*), Hyway, Rayon, Blackwall  
 7.50 x 14-4PR, Hyway, Rayon, Blackwall;  
 8.00 x 14-4PR, Hyway, Rayon, Blackwall; 8.00 x 14-4PR, Hyway, Rayon, Whitewall;  
 8.00 x 14-4PR (\*), Hyway, Nylon, Blackwall.

\* - Items with "\*" 4 ply construction.

# AMA Specifications—Passenger Car

MAKE OF CAR CHEVROLET MODEL YEAR 1964 DATE ISSUED 9-23-63 REVISED (o)  
 MODEL 11-1800 L-6 230 IN.<sup>3</sup> ENGINE  
 V-8 283 IN.<sup>3</sup> ENGINE

<b>BRAKES—SERVICE (cont.)</b>			Regular Production	Metallic	
Brake Lining	Bonded or riveted		Bonded	Welded	
	Front Shoe	Material	Molded Asbestos		
		Size (length x width x thickness)	Front wheel	Sintered Iron	
			Rear wheel	9.34 x 2.75 x .168	1.64 x 1.37 x .175
		Segments per shoe		9.34 x 2.00 x .168	2.00 x 1.00 x .175
	Segments per shoe		1	6	
	Rear Shoe	Material	Molded Asbestos		
		Size (length x width x thickness)	Front wheel	Sintered Iron	
Rear wheel			11.75 x 2.75 x .168	1.64 x 1.37 x .295	
Segments per shoe		11.75 x 2.00 x .168	2.00 x 1.00 x .295		
Segments per shoe		1	Front - 12; Rear - 10		

### BRAKES—PARKING

Type of control		Foot pedal for apply. "T" handled release
Location of control		Left of Steering Column
Operates on		Rear Service Brakes
If sepa- rate from service brakes	Type (internal or external)	--
	Drum diameter	--
	Lining size (length x width x thickness)	--

### FRAME or UNITIZED CONSTRUCTION

Type and description All welded "X" frame with box girder side rails, box section front suspension crossmember, channel section rear crossmember and reinforced box girder center beam. Special crossmember for mounting rear suspension upper control arms.

### SUSPENSION—GENERAL (See Supplemental page 19 for details on Air Suspension)\*

Provision for car leveling		Front Stabilizer Bar
Provision for brake dip control		Mounting Angle of Front Upper Control Arms
Provision for acc. squat control		Geometry of Rear Suspension Control Arms
Special provisions for car jacking		None
Shock absorber front & rear	Type	Direct, Double-Acting, Hydraulic
	Make	Delco
	Piston dia.	1.00
Other special features		--

### SUSPENSION—FRONT

Type and description Independent - SLA type with coil spring and concentric shock absorber, and spherically-jointed steering knuckle for each wheel.

\* Air Suspension:  
Air spring type  
Compressor data  
type  
make  
drive ratio

Normal operating pressures:  
spring rates  
leveling data

(Continued)

# AMA Specifications – Passenger Cars

MAKE OF CAR CHEVROLET MODEL YEAR 1964 DATE ISSUED 9-23-63 REVISED (a) 12-2-63

MODEL 11-1800 L-6 230 IN.<sup>3</sup> ENGINE V-8 283 IN.<sup>3</sup> ENGINE

## SUSPENSION FRONT (cont.)

Spring	Type	Coil, Right Hand Helix	
	Material	Steel Alloy	
	Size (coil design height & I.D.; bar length x dia.)	10.50 and 3.802 141.25 x .630	10.50 and 3.802 141.25 x .630
	Spring rate (lb. per in.)	275	275
	Rate at wheel (lb. per in.)	101.2	101.2
	Design load (lb. @ design height)	1790 @ 10.50	1880 @ 10.50
Stabilizer	Type (link, linkless, frameless)	Link	
	Material & bar diameter	Steel, .6875	

## STEERING

Manual (std., opt., NA)		Regular Production	
Power (std., opt., NA)		Optional	
Adjustable steering wheel (tilt, swing, other)	Type and description	Tilt: Tilt achieved by.. universally-jointing steering shaft at base of steering wheel; five-inch vertical travel range	
	(std., opt., NA)	Optional with power steering except with 3-Speed	
Wheel diameter	Manual	16.5	
	Power	16.5	
Turning diameter	Outside front	Wall to wall (l. & r.)	44.1
		Curb to curb (l. & r.)	40.8
	Inside rear	Wall to wall (l. & r.)	24.2
		Curb to curb (l. & r.)	24.5
Outside wheel angle with inside wheel at 20°		17.87°	

Manual	Gear	Type	Semi-Reversible, Recirculating Ball Nut		
		Make	Saginaw		
		Ratios	Gear	24.0:1	
			Overall	28.0:1	
No. wheel turns		5.8 (Lock to Lock)			
Power	Type (coaxial, linkage, etc.)		Linkage with Hydraulically operated cylinder		
	Make		Saginaw		
	Gear	Type	Same as Manual		
		Ratios	Gear	20.0:1	
			Overall	24.0:1	
	Pump driven by		Crankshaft Pulley		
	Number wheel turns		5.06 (Lock to Lock)		
Linkage	Type		Relay		
	Location (front or rear of wheels, other)		Front		
	Drag link (trans. or longit.)		None		
	Tie rods (one or two)		2		

(Continued)

# AMA Specifications – Passenger Car

MAKE OF CAR CHEVROLET MODEL YEAR 1964 DATE ISSUED 9-23-63 REVISED (a) 12-2-63

MODEL 11-1800 L-6 230 IN.<sup>3</sup> ENGINE V-8 283 IN.<sup>3</sup> ENGINE

## STEERING (cont.)

Steering Axis	Inclination at camber (deg.)		6 3/4 to 7 3/4
	Bearings (type)	Upper	Ball stud with non-metallic bearing surfaces
		Lower	Ball stud with non-metallic bearing surfaces
	Thrust	None required	
Wheel alignment (range and preferred)	Caster (deg.)		N 1/2 to P 1/2 (Curb)
	Camber (deg.)		O to P 1 (Curb)
	Toe-in (outside tread-inches)		1/32 - 3/32, per wheel (Curb)
Steering spindle & joint type			Forging with pad for mounting brake cylinder, spherical
Wheel spindle	Diameter	Inner bearing	1.2493 - 1.2498
		Outer bearing	.7492 - .7497
	Thread size		3/4-20 NEF 3 (modified)
	Bearing type		Taper Roller

## SUSPENSION—REAR

Type and description		4-Link; 3 Control Arms and Lateral Control Bar		
Drive and torq. taken through (see page 17)		Control Arms		
Spring	Type		Coil, Right Hand Helix	
	Material		Steel Alloy	
	Size (length x width, coil design height and I.D.; bar length & dia.)		9.88 and 3.638; 138.27 x .583	
	Spring rate (lb. per in.)		230	
	Rate at wheel (lb. per in.)		108.6	
	Design load (lb. at design height)		1520 @ 9.88	
	Mounting insulation type		None	
	If leaf	No. of leaves		--
		Inserts	Type and size	--
			Material	--
Shackle (comp. or tens.)		--		
Stabilizer	Type (link, linkless, frameless)		--	
	Material		--	
Track bar type			Lateral, frame to rear axle	

MAKE OF CAR CHEVROLET MODEL YEAR 1964 DATE ISSUED 9-23-63 REVISED <sup>(\*)</sup>

## CAR AND BODY DIMENSIONS—GENERAL

Dimensions herein are those adopted by the Society of Automotive Engineers. Brief descriptions of these dimensions are listed on pages 34-36. Complete definitions are listed in section E-1 of the SAE Aeronautical - Automotive Drawing Standards. The dimensions are developed from the following basic points:

1. Body dimensions are for all body styles.
2. All interior dimensions are taken with manikin 15.0 inches outboard of car centerline unless otherwise stated.
3. All interior dimensions are measured with the front seat in the lowest and rearmost position.
4. Unless otherwise specified, all exterior height dimensions are taken with a full design load which consists of 5 passengers, 300 lbs. front, 450 lbs. rear; includes spare wheel, tire and tools, and full complement of gas, oil, water and tires to recommended pressure, etc.
5. The SAE manikin with 90th percentile leg length will be used for recording purposes.
6. The H Point is the pivot center of the manikin's torso and thigh.
7. The D Point is the point of tangency of a horizontal line and the lowest point of the manikin.
8. The Torso Line is a line parallel to the small of manikin's back and extending through the H Point.

### EXTERIOR WIDTH DIMENSIONS

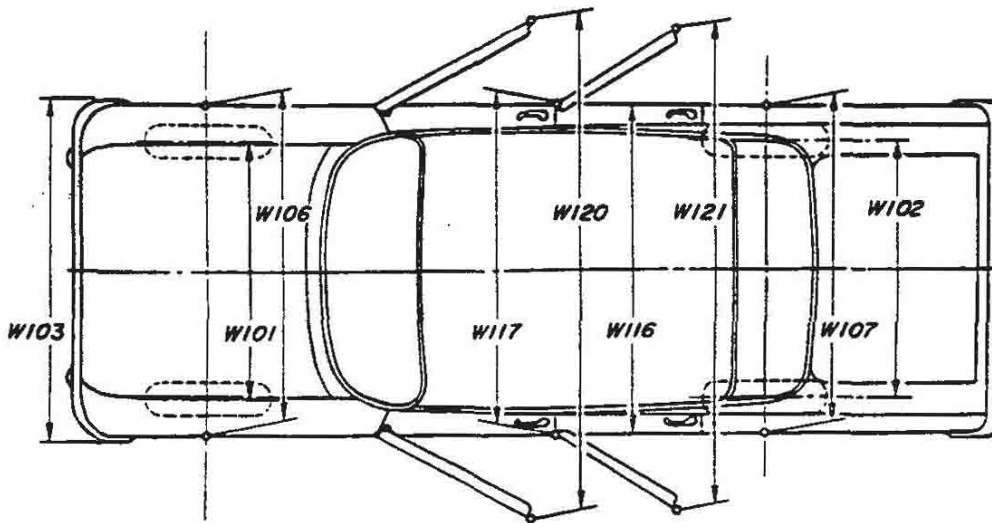

MODEL	Ref. No.	SEDANS		SPORT SEDAN	SPORT COUPE	CONVERTIBLE	STATION WAGONS
		2-Dr.	4-Dr.				
Tread - front	W101				60.3		61.3
Tread - rear	W102				59.3		60.3
Maximum overall car width	W103				78.1		
Maximum overall body width	W116				77.0		
Maximum body width at #2 pillar	W117	---		76.5		---	76.5
Front fender overall width	W106				76.7		
Rear fender overall width	W107				77.0		
Maximum overall car width - front doors open	W120	156.6		141.6		156.6	141.6
Maximum overall car width - rear doors open	W121	---	138.1	137.1		---	138.1

# AMA Specifications – Passenger Car

MAKE OF CAR CHEVROLET MODEL YEAR 1964 DATE ISSUED 9-23-63 REVISED(\*)

## EXTERIOR LENGTH DIMENSIONS

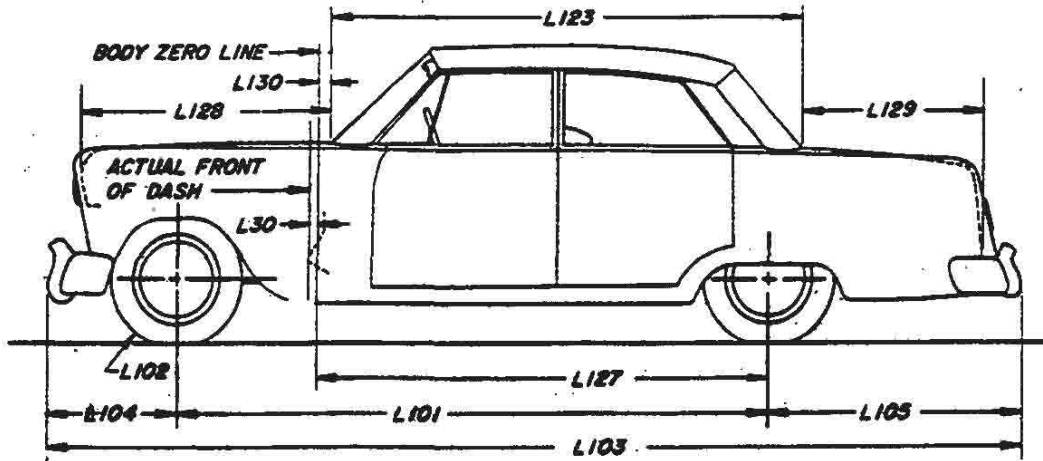

MODEL	Ref. No.	SEDANS		SPORT SEDAN	SPORT COUPE	CONVERTIBLE	STATION WAGON
		2-DR.	4-DR.				
Body zero line to actual front of dash	L30					.5	
Wheelbase	L101				119.0		
Overhang - front	L104				33.3		
Overhang - rear	L105				57.6		58.5
Overall length	L103				209.9		210.8
Hood length at car centerline	L128				51.2		
Body upper structure length at car centerline	L123	102.6		105.3	102.6	105.1	140.6
Deck length at car centerline	L129	49.2		46.5	49.2	46.8	--
Body zero line to centerline of rear wheels	L127				100.0		
Body zero line to windshield cowl point	L130				4.8		
Tire size	L102	Refer to Page 18					

# AMA Specifications— Passenger Car

Page 24

MAKE OF CAR CHEVROLET MODEL YEAR 1964 DATE ISSUED 9-23-63 REVISED (e)

## EXTERIOR HEIGHT DIMENSIONS

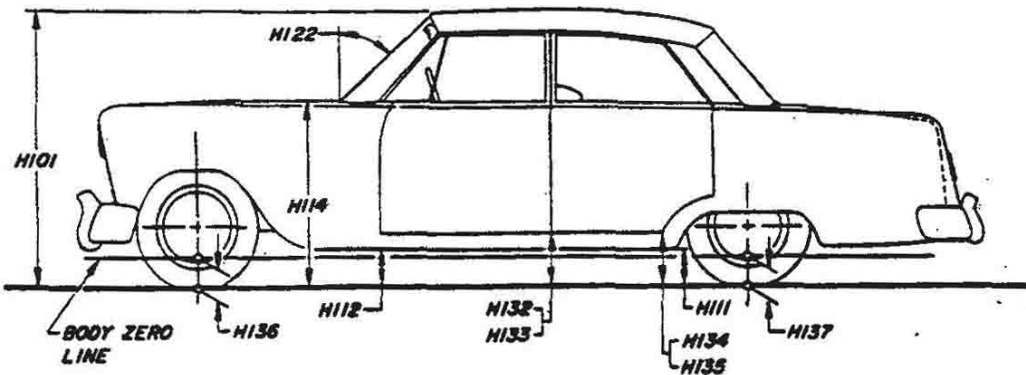

MODEL	Ref. No.	SEDANS		SPORT SEDAN	SPORT COUPE	CONVERTIBLE	STATION WAGON
		2-DR.	4-DR.				
Overall height	H101	56.2		54.9	55.1	55.8	56.7
Hood at rear to ground	H114	37.7				38.0	38.3
Rocker panel to ground - front	H112	8.9				9.2	9.5
Rocker panel to ground - rear	H111	8.5				8.8	9.1
Bottom of door to ground, open - front	H132	12.8	12.7			12.9	12.7
Bottom of door to ground, closed - front	H133	11.5	11.6			11.5	11.7
Bottom of door to ground, open - rear	H134	--	11.3		--	--	11.5
Bottom of door to ground, closed - rear	H135	--	11.3		--	--	11.5
Windshield slope angle	H122	55.5°					
Body zero to ground - front	H136	5.4					
Body zero to ground - rear	H137	5.4					5.0

# AMA Specifications—Passenger Car

MAKE OF CAR CHEVROLET MODEL YEAR 1964 DATE ISSUED 9-23-63 REVISED(°)

## GROUND CLEARANCE DIMENSIONS

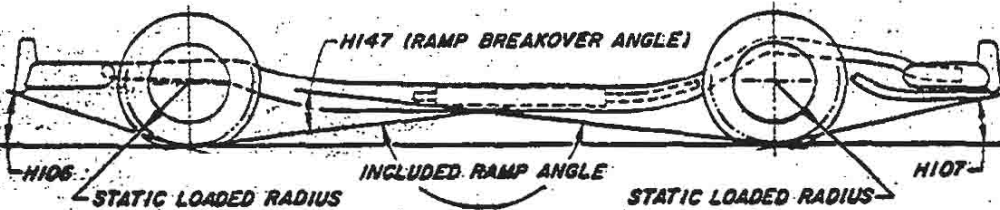
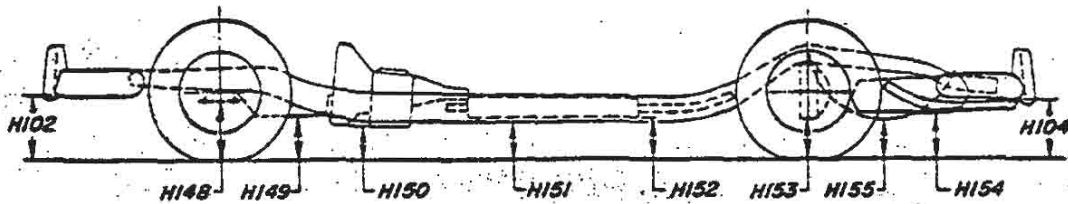

MODEL	Ref. No.	SEDANS		SPORT	SPORT	CONVERTIBLE	STATION WAGON
		2-DR.	4-DR.	SEDAN	COUPE		
Front bumper to ground	H102			12.4		12.7	13.0
Rear bumper to ground	H104			12.1		12.4	9.9
Angle of approach	H106			26°		27°	30°
Angle of departure	H107				13°		12°
Ramp breakover angle	H147			10°		13°	
Front suspension to ground	H148			7.1		7.4	7.7
Oil pan to ground	H149			6.6		6.9	7.2
Flywheel housing to ground	H150			6.4		6.7	7.0
Frame structure to ground	H151			7.1		7.4	7.7
Exhaust system to ground	H152			5.5		5.8	6.1
Rear axle differential to ground	H153			7.1		7.4	7.7
Fuel tank to ground	H154			8.0		8.3	9.3
Spare tire well to ground	H155			--		--	8.5
Minimum running ground clearance	H156			5.5		5.8	6.1

# AMA Specifications—Passenger Car

MAKE OF CAR CHEVROLET MODEL YEAR 1964 DATE ISSUED 9-23-63 REVISED (a)

## FRONT COMPARTMENT DIMENSIONS

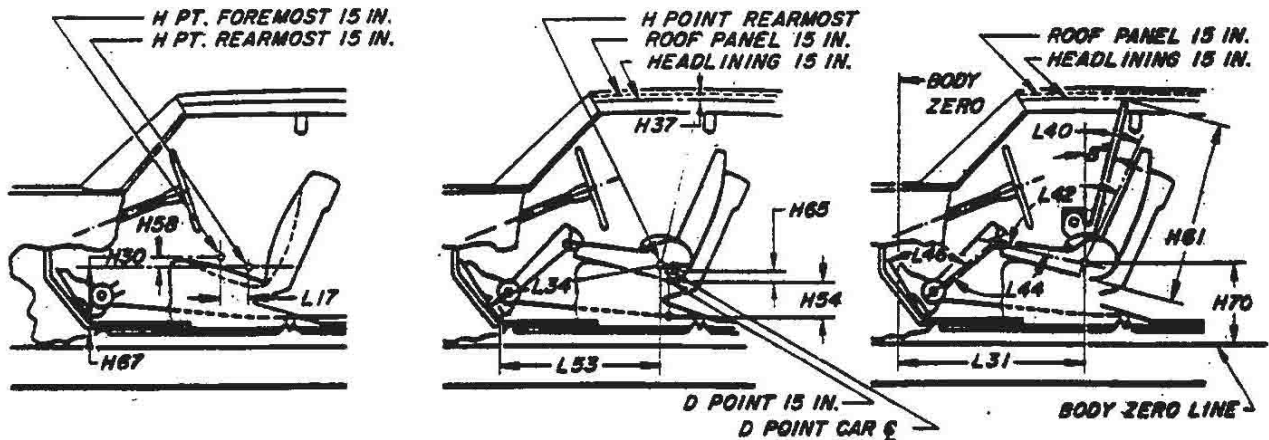

MODEL	Ref. No.	SEDANS		SPORT SEDAN	SPORT COUPE		CONVERTIBLE		STATION WAGON
		2-DR.	4-DR.		(a)	(b)	(a)	(b)	
H Point to body zero line	L31	42.5			42.0	41.8	42.0	41.8	42.5
H Point to body zero line - front	H70	NA							
Effective head room	H61	39.2		38.5	38.1	38.3	39.1	39.3	39.2
Headlining to roof height	H37			.5			—		.9
Maximum effective leg room - accelerator	L34	41.8			41.4	41.3	41.4	41.3	41.8
H Point to heel point	H30	8.6			8.4		8.6	8.4	8.6
Depressed floor covering thickness	H67	.3			.2		.3		.2
Back angle	L40	24°			26°	26°	23°	26°	25°
Hip angle	L42	96°			97°	95°	94°	95°	96°
Knee angle	L44	128°			125°	124°	125°	124°	128°
Foot angle	L46	87°			86°				88°
D Point differential, side to center	H65	.7			.5	--	.6	--	.7
D Point to tunnel	H54	2.8			2.7	--	2.7	--	2.8
H Point to accelerator floor point	L53	34.0			33.6	33.5	33.6	33.5	34.0
H Point travel	L17	4.8							
H Point rise	H58	.8			.7	.8	.7	.8	.7

(a) Bench seat; (b) Bucket seat

# AMA Specifications – Passenger Car

**MAKE OF CAR:** CHEVROLET **MODEL YEAR:** 1964 **DATE ISSUED:** 9-23-63 **REVISED (a):** 12-2-

## REAR COMPARTMENT DIMENSIONS

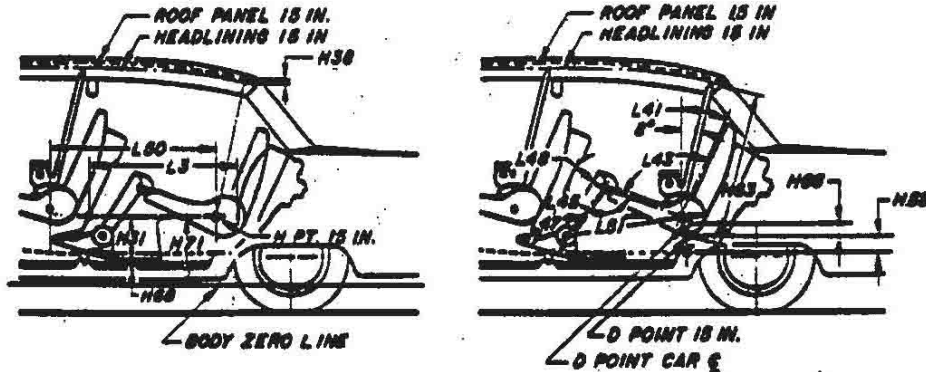

MODEL	Ref. No.	SEDANS		SPORT SEDAN	SPORT COUPE		CONVERTIBLE		STATION WAGON
		2-DR.	4-DR.		(a)	(b)	(a)	(b)	
H Point couple distance	L50	34.8		33.7	33.1	33.2	33.1	33.2	34.9
H Point to body zero line - rear	H71	NA							
Effective head room	H63	38.0		37.2	38.3	38.3	38.1	38.1	39.8
Headlining to roof height	H38	.8		.6	.5	--	--	--	.8
Minimum effective leg room	L51	38.3		36.8	35.0	36.1	35.0	36.1	38.6
H Point to heel point	H31	11.8		12.0	10.5	10.4	10.5	10.4	11.7
Depressed floor covering thickness	H68	.4							
Minimum knee room	L48	4.6		3.6	3.4	3.7	3.4	3.7	4.9
Rear compartment room	L3	27.8		26.8	26.1	26.1	25.7	26.2	28.4
Back angle	L41	25°			19°				23°
Hip angle	L43	92°		90°	77°	79°	77°	79°	91°
Knee angle	L45	103°	106°	99°	90°	96°	90°	96°	108°
Foot angle	L47	114°		110°	110°	109°	110°	109°	114°
D Point differential, side to center	H66	.4		.8	.8	.8	.8	.8	.5
D Point to tunnel	H55	1.7		2.2	.7	.7	.7	.7	1.7

(a) Bench seat; (b) Bucket seat

# AMA Specifications – Passenger Car

MAKE OF CAR CHEVROLET MODEL YEAR 1964 DATE ISSUED 9-23-63 REVISED (a) 12-2-63

## SEAT AND ENTRANCE DIMENSIONS

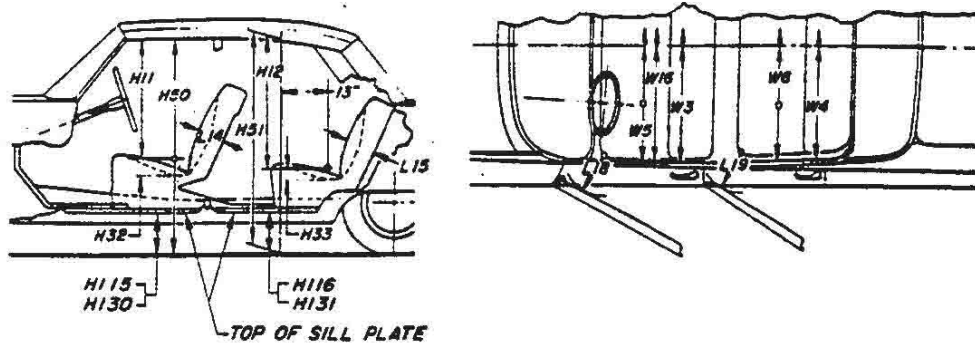

MODEL	Ref. No.	SEDANS		SPORT SEDAN	SPORT COUPE		CONVERTIBLE		STATION WAGON	
		Z-DR.	4-DR.		(a)	(b)	(a)	(b)		
Shoulder room - front	W3	58.8								
Hip room - front	W5	63.7		63.5	63.6					
Seat width - front	W16	57.6			27.4	57.6	27.4	57.6		
Upper body opening to ground - front	H50	50.6		50.8	49.5	49.5	49.1	49.1	50.6	
Entrance height - front	H11	30.1		30.3	29.1	29.3	28.7	28.8	30.1	
Step height - front (design load)	H115	12.7			13.0				13.3	
Step height - front (curb load)	H130	14.7			15.0				15.3	
Entrance foot clearance - front	L18	14.9			14.3	14.9	14.3	14.9		
Seat cushion deflection - front	H32	4.2		4.5	4.7	4.2	4.7	4.2	4.2	
Seat back thickness - front	L14	7.1		7.4	7.4	7.4	7.4	6.4	7.4	
Shoulder room - rear	W4	57.5		58.2	57.6		51.5		58.0	
Hip room - rear	W6	62.6		63.3	55.2		51.7		63.4	
Upper body opening to ground - rear	H51	--		50.3	--	--	--		50.5	
Entrance height - rear	H12	--	30.5	30.1	--	--	--		30.7	
Step height - rear (design load)	H116	--	12.7			---				13.3
Step height - rear (curb load)	H131	--	12.7			---				13.3
Entrance foot clearance - rear	L19	11.6	11.7	11.3	9.0	9.6	9.0	9.6	13.0	
Seat cushion deflection - rear	H33	3.8	4.3	5.1	4.3				4.4	
Seat back thickness - rear	L15	8.3		9.0	7.4	7.4	7.7	7.7	6.1	

(a) Bench seat; (b) Bucket seat

# AMA Specifications – Passenger Car

MAKE OF CAR CHEVROLET MODEL YEAR 1964 DATE ISSUED 9-23-63 REVISED (e)

## VISION AND CONTROL DIMENSIONS

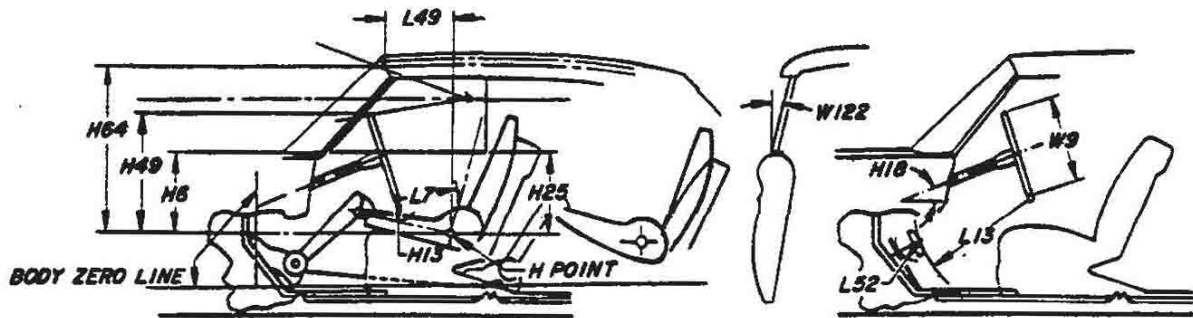

MODEL	Ref. No.	SEDANS		SPORT SEDAN	SPORT COUPE		CONVERTIBLE		STATION WAGON
		2-DR.	4-DR.		(a)	(b)	(a)	(b)	
H Point to windshield bottom DLO	H6	19.0			19.2	19.0	19.2	19.0	
H Point to windshield upper DLO	H64	33.1	32.8	31.0	31.8	32.0	31.7	31.9	32.8
H Point to windshield upper DLO	L49	12.0		15.0	13.7	13.5	13.7	13.5	12.0
Belt height - front	H25	16.8			17.0	16.8	17.0	16.8	
Steering wheel center to centerline of car	W7				15.9				
Steering wheel maximum outside diameter	W9				17.0				
Steering column angle - horizontal	H18				16.5°				
H Point to top of steering wheel	H49				23.3°				
Steering wheel torso clearance	L7	11.3		10.9	10.8	10.7	10.8	11.3	
Steering wheel thigh clearance	H13	3.5		3.4		3.5			
Brake pedal knee clearance	L13				24.3				
Brake pedal to accelerator	L52				4.3				
Tumble-home	W122				11.8°				

(a) Bench seat; (b) Bucket seat

# AMA Specifications – Passenger Car

MAKE OF CAR CHEVROLET MODEL YEAR 1964 DATE ISSUED 9-23-63 REVISED (o)

## LUGGAGE COMPARTMENT

MODEL	Ref. No.	SEDANS		SPORT	SPORT	CONVERTIBLE	STATION WAGON	
		2-DR.	4-DR.	SEDAN	COUPE			
Usable luggage capacity (See instructions)					19.0		--	
Liftover height	H195				22.1		--	
Position of spare tire storage		Horizontal on trunk forward shelf, left side (b)						(a)
Method of holding lid open		Torsion Bars, Counterbalanced						

## THIRD SEAT DIMENSIONS

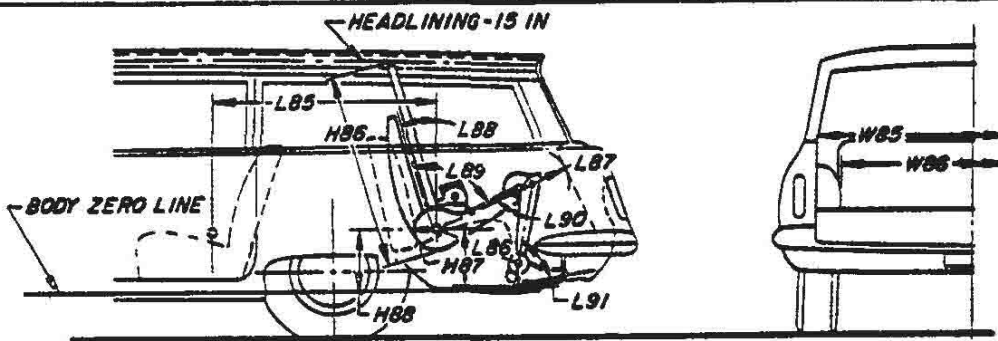

MODEL	Ref. No.	1645-1845
Seat facing direction		Rearward
Shoulder room	W85	52.0
Hip room	W86	46.7
H Point couple distance	L85	40.0
H Point to body zero line - third seat	H88	NA
Effective head room	H86	37.2
Effective leg room	L86	32.5
H Point to heel point	H87	12.3
Knee room	L87	9.5
Back angle	L88	18°
Hip angle	L89	80°
Knee angle	L90	82°
Foot angle	L91	113°

(a) Behind right rear quarter access panel; (b) Horizontal, rear right side.

# AMA Specifications—Passenger Car

MAKE OF CAR CHEVROLET MODEL YEAR 1964 DATE ISSUED 9-23-63 REVISED (a) 12-2-66

## STATION WAGON—CARGO SPACE DIMENSIONS

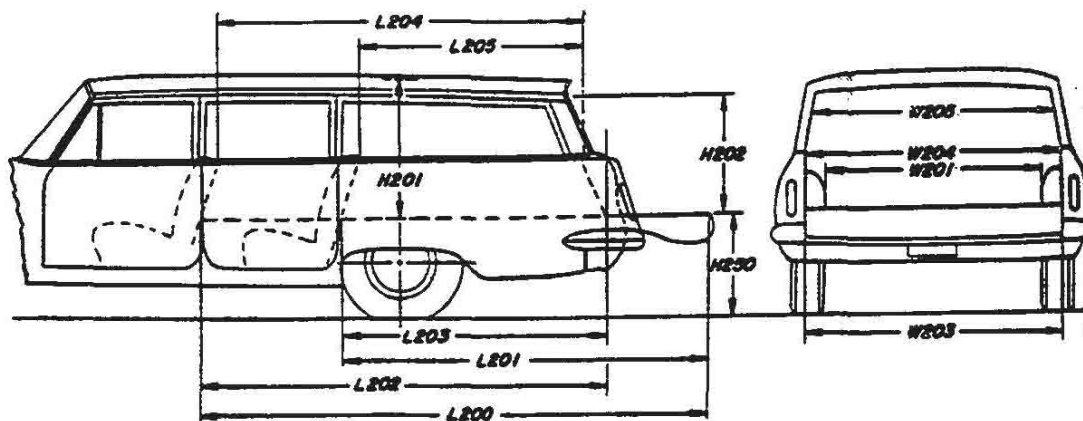

MODEL	Ref. No.	6-PASSENGER	9-PASSENGER
Floor length from back of front seat at floor level to end of lowered tail gate or floor	L200		118.7
Floor length from back of second seat at floor level to end of lowered tail gate or floor	L201		84.7
Floor length from back of front seat at floor level to inside of closed tail gate	L202		94.2
Floor length from back of second seat at floor level to inside of closed tail gate	L203		60.2
Minimum horizontal distance from top rear of front seat back to inside of tail gate at belt	L204		82.2
Minimum horizontal distance from top rear of second seat back to inside of tail gate at belt	L205		47.2
Maximum width of cargo space at floor - specify location	W200		62.2
Minimum distance between wheel houses at floor level	W201		46.1
Rear end opening width at floor	W203		56.4
Rear end opening width at belt	W204		54.7
Maximum width of rear opening above belt	W205		54.2
Maximum height - floor covering to headlining at centerline of rear axle	H201		31.5
Maximum height of rear opening - tail and lift gates open	H202		30.5
Platform height from ground to top of tail gate floor covering at rear most edge of tail gate - curb weight	H250		23.3
Rear end closure (e.g., one piece door, hinged left - sliding glass, drop tail gate)		Hinged tailgate with folding link supports and manual retractable rear window (a)	
Cargo volume index (cu. ft.) W4 x L204 x H201 1728			87.0 (b)

(a) Electrically operated window on 9-passenger (optional on 6-passenger)

(b) Plus 10.5 cu. ft. for hidden compartment in 6-passenger, plus 5.7 cu. ft. in 9-passenger. Form Rev. 5-6

# AMA Specifications - Passenger Car

Page 32

MAKE OF CAR CHEVROLET MODEL YEAR 1964 DATE ISSUED 9-23-63 REVISED (\*)12-2-63

<b>MODEL</b>	SEDANS	SPORT	SPORT	CONVERTIBLE	STATION WAGON
	2-DR. 4-DR.	SEDAN	COUPE		

## BODY - MISCELLANEOUS INFORMATION

Drs. hinged (front, rear)	Front doors	Front				
	Rear doors	Front				
Type of finish (lacquer, enamel, other)		Acrylic Lacquer				
Hood counterbalanced (yes, no)		Yes				
Hood release control (Internal, external)		External				
Vehicle (Serial) No. Location		Left front body hinge pillar				
Engine No. Location		On pad, front right hand side of cylinder block				
Theft protection - type		Shielded ignition lock terminals, key removable in "Lock" or "On" position				
Vent window control method (crank, friction pivot)	Front	Crank				
	Rear	None				
Seat cushion type	Front	Formed wire and foam pad				
	Rear	Formed wire and foam pad				
	3rd seat	F.wire & foam pad				
Seat back type	Front	Formed wire and cotton				
	Rear	Formed wire and cotton				
	3rd seat	Formed wire & cotton				
Windshield glass type (i.e., curved - laminated plate)		One piece, single curved, laminated				
Backlight glass type (i.e., compound curved - tempered plate, three piece)		Compound curve., solid tempered plate (a)				
Side glass type (i.e., curved - tempered plate)		Flat, safety-solid plate				
Side glass exposed surface area		1346.3	1322.8	1360.6	1236.2	1115.5 2669.3
Windshield glass exposed surface area		1587.5		1405.7	1461.2	1461.2 1587.5
Backlight glass exposed surface area		1257.1		1239.9	941.9	1103.0 938.3
Total glass exposed surface area		4190.9	4167.4	4006.2	3639.3	3679.7 5200.1

## BODY - CONVENIENCE EQUIPMENT (Indicate whether standard, optional or NA on each series)

Power windows	Side Windows	Optional				
	Vent Windows	NA				
	Backlight or tailgate	Standard on 9-passenger wagon, optional on 6-passenger				
Power seats (specify type as well as availability)		6 way electric, optional				
Reclining front seat back		NA				
Front seat headrest		NA				
Radios (specify type as well as availability)		Push Button, manual, AM-FM optional				
Rear seat speaker		Optional				
Power Antenna		NA				
Clock		Standard on 13-14-17-1800, Optional on 11-12-15-1600				
Air Conditioner (specify type availability)		All weather, deluxe, cool pack optional				

(a) Plastic on convertible.

# AMA Specifications – Passenger Car

MAKE OF CAR CHEVROLET MODEL YEAR 1964 DATE ISSUED 9-23-63 REVISED (12-2-63)

## WEIGHTS

Model	CURB WEIGHT - POUNDS			% PASS. WEIGHT DISTRIBUTION				SHIPPING * WEIGHT	
	Front	Rear	Total	Pass. In Front		Pass. In Rear		Front	Rear
				Front	Rear	Front	Rear		
		<u>230</u>	<u>283</u>						<u>230</u> <u>283</u>
<b>Biscayne</b>									
1111 1211		3375	3520	30	70				3230 3365
1135 1235		3840	3975	30	70				3700 3820
1169 1269		3445	3590	30	70				3300 3430
<b>Bel Air</b>									
1511 1611		3380	3525	30	70				3235 3370
1535 1635		3845	3980	30	70				3705 3825
1545 1645		3885	4020	22	78				3745 3865
1569 1669		3450	3595	30	70				3305 3440
<b>Impala</b>									
1735 1835		3870	4000	30	70				3725 3850
1739 1839		3515	3645	30	70				3370 3490
1745 1845		3915	4045	22	78				3770 3895
1747 1847		3440	3570	37	63				3295 3415
1767 1867		3545	3680	37	63				3400 3525
1769 1869		3485	3615	30	70				3340 3460
<b>Impala Super Sport</b>									
1347 1447		3470	3605	37	63				3325 3450
1367 1467		3580	3710	37	63				3435 3555
<b>Accessories &amp; Equipment Differential Weights</b>		<u>230</u>	<u>283</u>						Remarks
Air Conditioning, Deluxe		+122	+125						
Brakes, Power		+ 10	+ 10						
Less Heater		- 22	- 22						
Radio, Manual		+ 7	+ 7						
Radio, Push Button		+ 9	+ 9						
Seat, Power		+ 22	+ 22						
Steering, Power		+ 30	+ 30						
Transmission, Overdrive		+ 35	+ 35						
Transmission, Powerglide		+ 18	+ 18						
Windows, Power		+ 19	+ 19						
Air Conditioning, Custom		+106	+112						
Comfort & Convenience		+ 6	+ 6						
Radio, AM-FM		+ 10	+ 10						

\* These are weights that are reported to states for licensing purposes.

## DIMENSION DEFINITIONS

- W3 SHOULDER ROOM - FRONT. The minimum lateral dimension between the door garnish moldings or nearest interference. Measured at H Point station.
- W4 SHOULDER ROOM - REAR. Measured in the same manner as W3.
- W5 HIP ROOM - FRONT. The lateral dimension through H Point to trimmed surfaces.
- W6 HIP ROOM - REAR. Measured in the same manner as W5.
- W7 STEERING WHEEL CENTER TO CENTERLINE OF CAR. Measured horizontally from steering wheel center to centerline of car. The point at steering wheel center is located in the surface plane of wheel.
- W9 STEERING WHEEL MAXIMUM OUTSIDE DIAMETER. Define if other than round.
- W16 SEAT WIDTH - FRONT. The maximum trimmed width of front seat cushion.
- W85 SHOULDER ROOM - THIRD SEAT. Measured in the same manner as W3.
- W86 HIP ROOM - THIRD SEAT. Measured in the same manner as W5.
- W101 TREAD - FRONT. Measured at centerline of tires, with nominal camber, at ground.
- W102 TREAD - REAR. Measured at centerline of tires at ground.
- W103 MAXIMUM OVERALL CAR WIDTH. Include bumpers, moldings, or sheet metal protrusions.
- W106 FRONT FENDER OVERALL WIDTH. Measured at centerline of front wheels, excluding moldings.
- W107 REAR FENDER OVERALL WIDTH. Measured at centerline of rear wheels, excluding moldings.
- W116 MAXIMUM OVERALL BODY WIDTH. Measured across body, excluding hardware and applied moldings, but including fenders when integral with body.
- W117 MAXIMUM BODY WIDTH AT #2 PILLAR. Measured across body at #2 pillar, excluding hardware and applied moldings.
- W120 MAXIMUM OVERALL CAR WIDTH, FRONT DOORS OPEN. Measured with front doors in maximum hold-open position.
- W121 MAXIMUM OVERALL CAR WIDTH, REAR DOORS OPEN. Measured in same manner as W120.
- W122 TUMBLE-HOME. The angle from vertical to the front door glass outer surface or the chord of a curved door glass, measured at the front H Point station.
- L3 REAR COMPARTMENT ROOM. The horizontal dimension from the back of front seat to front of rear seat back at a height tangent to the top of rear seat cushion.
- L7 STEERING WHEEL TORSO CLEARANCE. The minimum distance from the back edge of steering wheel, in straight-ahead position, to the Torso Line.
- L13 BRAKE PEDAL KNEE CLEARANCE. The minimum dimension from the lower edge of the steering wheel to the brake pedal face centerline.
- L14 SEAT BACK THICKNESS - FRONT. The maximum thickness of the seat back, excluding bolsters.
- L15 SEAT BACK THICKNESS - REAR. Measured in the same manner as L14.
- L17 H POINT TRAVEL. The horizontal dimension between the H Point in the most forward and rearward seat positions.
- L18 ENTRANCE FOOT CLEARANCE - FRONT. The minimum horizontal dimension between seat and normal line of door or pillar at a height between the sill plate bead and 4.0 inches above the bead. Door should be in the maximum hold-open position.
- L19 ENTRANCE FOOT CLEARANCE - REAR. Measured in the same manner as L18 on four-door models. On two-door styles, the minimum dimension between rear corner of front seat, with front seat back tilted forward, and trimmed lock pillar, built-in quarter armrest panel, or rear seat cushion at a height between the sill plate bead and 4.0 inches above the bead.
- L30 BODY ZERO LINE TO ACTUAL FRONT OF DASH. If actual Front of Dash is to the rear of Body Zero Line, it is identified by a minus (-) sign.
- L31 H POINT TO BODY ZERO LINE - FRONT. Horizontal dimension.
- L34 MAXIMUM EFFECTIVE LEG ROOM - ACCELERATOR. Measured along a diagonal line from ankle pivot center to H Point plus a constant of 10.0 inches. Measured with the right foot on accelerator pedal.
- L40 BACK ANGLE - FRONT. The angle between a vertical line through the H Point and the Torso Line.
- L41 BACK ANGLE - REAR. Measured in the same manner as L40.
- L42 HIP ANGLE - FRONT. The angle between Torso Line and a line extending from knee pivot center to H Point.
- L43 HIP ANGLE - REAR. Measured in the same manner as L42.
- L44 KNEE ANGLE - FRONT. The angle between a line from H Point to knee pivot center and a line from the knee pivot center to the ankle pivot center.
- L45 KNEE ANGLE - REAR. Measured in the same manner as L44.
- L46 FOOT ANGLE - FRONT. The angle between a line extended from the knee pivot center through the ankle pivot center and a line tangent to the sole and heel of mankin bare foot.
- L47 FOOT ANGLE - REAR. Measured in the same manner as L46.
- L48 MINIMUM KNEE ROOM - REAR. The minimum dimension from the knee pivot center to the back of front seat back.
- L49 H POINT TO WINDSHIELD UPPER DLO. The horizontal dimension from H Point to the point of tangency of horizontal line of vision (described in dimension H64) with body upper structure.

**DIMENSION DEFINITIONS (cont.)**

- L50 H POINT COUPLE DISTANCE.** The horizontal dimension from the front seat H Point to the rear seat H Point.
- L51 MINIMUM EFFECTIVE LEG ROOM - REAR.** Measured along a diagonal line from ankle pivot center to H Point plus a constant of 10.0 inches. Measured with the foot positioned to nearest interference between seat structure and toe, instep or lower leg.
- L52 BRAKE PEDAL TO ACCELERATOR.** The minimum dimension from center of brake pedal face to accelerator. Measured in the side view.
- L53 H POINT TO ACCELERATOR FLOOR POINT.** The horizontal dimension from intersection of accelerator and depressed floor covering to the H Point.
- L85 H POINT COUPLE DISTANCE - THIRD SEAT.** The horizontal dimension from the second seat H Point to the third seat H Point.
- L86 EFFECTIVE LEG ROOM - THIRD SEAT.** Measured in the same manner as L51. With rear-facing third seat, foot is positioned in foot well or to nearest interference with rear end or rear closure.
- L87 KNEE ROOM - THIRD SEAT.** Measured in the same manner as L48. With rear-facing third seat, dimension is measured to rear closure.
- L88 BACK ANGLE - THIRD SEAT.** Measured in the same manner as L40.
- L89 HIP ANGLE - THIRD SEAT.** Measured in the same manner as L42.
- L90 KNEE ANGLE - THIRD SEAT.** Measured in the same manner as L44.
- L91 FOOT ANGLE - THIRD SEAT.** Measured in the same manner as L46.
- L101 WHEELBASE.**
- L102 TIRE SIZE.**
- L103 OVERALL LENGTH.** Include bumper guards if standard equipment.
- L104 OVERHANG - FRONT.** Measured from C/L of front wheels to front of car, including bumper guards if standard equipment.
- L105 OVERHANG - REAR.** Measured from C/L of rear wheels to rear of car, including bumper guards if standard equipment.
- L123 BODY UPPER STRUCTURE LENGTH AT CAR CENTERLINE.** The horizontal dimension from the theoretical intersection of extended windshield glass plane and normal cowl surface to the theoretical intersection of extended back window glass plane and normal deck surface; or in the case of a Fastback roof or Station Wagon, to back glass lower reveal molding, or rubber when molding is not used.
- L127 BODY ZERO LINE TO CENTERLINE OF REAR WHEELS.** A horizontal dimension.
- L128 HOOD LENGTH AT CAR CENTERLINE.** The horizontal dimension from the foremost point on sheet metal hood surface, excluding series identification or ornamentation, to the theoretical intersection of extended windshield glass plane and normal cowl surface.
- L129 DECK LENGTH AT CAR CENTERLINE.** The horizontal dimension from the rearmost point of the body sheet metal (visible above-bumper), excluding series identification or ornamentation, to the theoretical intersection of extended back window glass plane and normal deck surface.
- L130 BODY ZERO LINE TO WINDSHIELD COWL POINT.** The horizontal dimension from body zero line to the theoretical intersection of extended windshield glass plane and normal cowl surface.
- H6 H POINT TO WINDSHIELD BOTTOM DLO.** Vertical dimension.
- H11 ENTRANCE HEIGHT - FRONT.** The vertical dimension from H Point to upper trimmed body opening.
- H12 ENTRANCE HEIGHT - REAR.** The vertical dimension from H Point to the upper trimmed body opening at a section 13.0 inches forward of the H Point.
- H13 STEERING WHEEL THIGH CLEARANCE.** The minimum dimension from the bottom of steering wheel, in straight-ahead position, to centerline of thigh.
- H18 STEERING COLUMN ANGLE - HORIZONTAL.** The angle the centerline of steering column makes with the horizontal.
- H25 BELT HEIGHT - FRONT.** The vertical dimension from H Point to bottom of side window DLO.
- H30 H POINT TO HEEL POINT - FRONT.** The vertical dimension from the H Point to the manikin accelerator heel point on the depressed floor covering.
- H31 H POINT TO HEEL POINT - REAR.** The vertical dimension from the H Point to the manikin heel point on the depressed floor covering.
- H32 SEAT CUSHION DEFLECTION - FRONT.** The vertical dimension from a point on the undepressed seat cushion to the depressed seat cushion. Measured at the H Point station.
- H33 SEAT CUSHION DEFLECTION - REAR.** Measured in the same manner as H32.
- H37 HEADLINING TO ROOF HEIGHT - FRONT.** The dimension from the intersection of the headlining and the extended effective head room line to the roof panel. Measured perpendicularly to the roof panel.
- H38 HEADLINING TO ROOF HEIGHT - REAR.** Measured in the same manner as H37.
- H49 H POINT TO TOP OF STEERING WHEEL.** The vertical dimension from the H Point to top of steering wheel, in straight-ahead position.
- H50 UPPER BODY OPENING TO GROUND - FRONT.** The vertical dimension from a point on the trimmed body opening to the ground. Measured at the H Point station.
- H51 UPPER BODY OPENING TO GROUND - REAR.** The vertical dimension from a point on the trimmed body opening to the ground. Measured 13.0 inches forward of the H Point.

**DIMENSION DEFINITIONS (cont.)**

- H54 D POINT TO TUNNEL - FRONT. The vertical dimension from the D Point, at car centerline, to top of tunnel.
- H55 D POINT TO TUNNEL - REAR. Measured same manner as H54.
- H58 H POINT RISE. The vertical dimension between the H Point in the most forward and rearward seat position.
- H61 EFFECTIVE HEAD ROOM - FRONT. The dimension from H Point to the headlining, plus a constant of 4.0 inches. Measured along a line  $6^\circ$  to rear of vertical.
- H63 EFFECTIVE HEAD ROOM - REAR. Measured same as H61.
- H64 H POINT TO WINDSHIELD UPPER DLO. Vertical dimension from H Point to highest horizontal line of vision through windshield at 15 inch section.
- H65 D POINT DIFFERENTIAL, SIDE TO CENTER - FRONT. Vertical dimension from side occupant to center occupant D Point.
- H66 D POINT DIFFERENTIAL, SIDE TO CENTER - REAR. Measured in the same manner as H65.
- H67 DEPRESSED FLOOR COVERING THICKNESS - FRONT. The vertical dimension from manikin accelerator heel point normally to underbody sheet metal immediately below heel point.
- H68 DEPRESSED FLOOR COVERING THICKNESS - REAR. Measured same as H67.
- H70 H POINT TO BODY ZERO LINE - FRONT. Vertical dimension.
- H71 H POINT TO BODY ZERO LINE - REAR. Vertical dimension.
- H86 EFFECTIVE HEAD ROOM - THIRD SEAT. Measured in the same manner as H61.
- H87 H POINT TO HEEL POINT - THIRD SEAT. Measured in the same manner as H31.
- H88 H POINT TO BODY ZERO LINE - THIRD SEAT. Vertical dimension.
- H101 OVERALL HEIGHT. Measured with full design load.
- H102 FRONT BUMPER TO GROUND. Minimum dimension.
- H104 REAR BUMPER TO GROUND. Minimum dimension.
- H106 ANGLE OF APPROACH. The angle between the ground and a line tangent to the front tire static loaded radius arc and the first point of interference, i.e. bumper, guard, gravel deflector, fender or other interfering component, excluding license plate.
- H107 ANGLE OF DEPARTURE. The angle between the ground and a line tangent to the rear tire static loaded radius arc and the first point of interference, i.e. bumper, guard, gravel deflector, tail pipe, fender or other interfering component, excluding license plate.
- H111 ROCKER PANEL TO GROUND - REAR. The vertical dimension from ground to bottom of rocker panel, excluding flanges. Measured at front of rear wheel opening.
- H112 ROCKER PANEL TO GROUND - FRONT. The vertical dimension from ground to bottom of rocker panel, excluding flanges. Measured at foremost point of rocker panel.
- H114 HOOD AT REAR TO GROUND. Measured from hood opening line on shroud, exclusive of moldings.
- H115 STEP HEIGHT - FRONT (DESIGN LOAD). The vertical dimension from top of sill plate base, at C/L of front door sill plate, to ground.
- H116 STEP HEIGHT - REAR (DESIGN LOAD). Measured in same manner as dimension H115.
- H122 WINDSHIELD SLOPE ANGLE. The angle between a vertical line and the windshield surface at car centerline. On compound-curved windshields the chord of the arc is used and limited to that section of the windshield comprehended by an 18-inch chord.
- H130 STEP HEIGHT - FRONT (CURB LOAD). The vertical dimension from top of sill plate, at C/L of front door sill plate, to ground.
- H131 STEP HEIGHT - REAR (CURB LOAD). Measured same as H130.
- H132 BOTTOM OF DOOR TO GROUND, OPEN - FRONT. Measured from bottom outside corner of door with door in maximum hold-open position.
- H133 BOTTOM OF DOOR TO GROUND, CLOSED - FRONT. Same point on door as H132 dimension, with door closed.
- H134 BOTTOM OF DOOR TO GROUND, OPEN - REAR. Measured in same manner as H132.
- H135 BOTTOM OF DOOR TO GROUND, CLOSED - REAR. Measured in same manner as H133.
- H136 BODY ZERO TO GROUND - FRONT. A vertical dimension measured at front wheel centerline.
- H137 BODY ZERO TO GROUND - REAR. A vertical dimension measured at rear wheel centerline.
- H147 RAMP BREAKOVER ANGLE. Supplement of included ramp angle ( $180^\circ$  minus included ramp angle) over which car can pass without interference; measured with car sitting on a level surface, using lines tangent to arcs of front and rear static loaded radii and intersecting at point on underside of car which defines the smallest angle.
- H148 FRONT SUSPENSION TO GROUND. Minimum clearance from lower control arm inner shaft or lowest point on the car centerline.
- H149 OIL PAN TO GROUND. Minimum clearance measured from sheet metal or drain plug.
- H150 FLYWHEEL/CONVERTER HOUSING AND TRANSMISSION ASSEMBLY TO GROUND. Minimum clearance.
- H151 FRAME STRUCTURE TO GROUND. Minimum clearance measured approximately midway between front and rear axles. In this measurement, cross bars and X-members shall be considered part of frame.
- H152 EXHAUST SYSTEM TO GROUND. Minimum clearance. Specify location.
- H153 REAR AXLE DIFFERENTIAL SYSTEM TO GROUND. Minimum clearance.
- H154 FUEL TANK TO GROUND. Minimum clearance measured from sheet metal or drain plug, but excluding supports or straps.
- H155 SPARE TIRE WELL TO GROUND. Minimum clearance.
- H156 MINIMUM RUNNING GROUND CLEARANCE. Location of measurement on the car to be clearly recorded.
- H195 LIFTOVER HEIGHT. Vertical dimension from luggage compartment lower opening to ground.

# AMA Specifications – Passenger Car

## INDEX

SUBJECT	PAGE NO.	SUBJECT	PAGE NO.
Angles of Approach, Departure .....	25	Lamp Height & Spacing .....	14
Automatic Transmission .....	1, 16	Legroom .....	26, 27, 30
Axis, Steering .....	21	Lengths - Overall .....	1, 23
Axis, Rear .....	1, 17	Lifters, Valve .....	5
Battery .....	10	Linings - Clutch, Brake .....	15, 19
Bearings, Engine .....	4, 5, 6	Lubrication .....	6, 7, 15, 16, 17
Belts - Fan, Generator, Water Pump .....	9	Luggage Capacity .....	30
Body - General Information, types .....	Title, 1, 22, 32	Motor, Starting .....	10
Exterior Dimensions .....	1, 22, 23, 24	Muffler .....	7
Interior Dimensions .....	26, 27, 28, 29, 30	Overdrive .....	16
Clearance Dimensions .....	25	Piston Pins & Rings .....	2, 4
Brakes - Parking, Service, Power .....	18, 19	Pistons .....	2
Camber .....	21	Power Brakes .....	18
Camshaft .....	5	Power Steering .....	20
Capacities .....		Power Teams .....	3
Cooling System .....	9	Propeller Shaft, Universal Joints .....	16, 17
Fuel Tank .....	8	Pumps - Oil, Fuel .....	7, 8
Lubricants .....		Water .....	9
Engine Crankcase .....	7	Radiator, Hoses .....	9
Transmission and Overdrive .....	15, 16	Ramp Break-over Angle .....	25
Rear Axle .....	17	Ratios - Axle .....	1, 3, 17
Carburetor .....	3, 8	Compression .....	1, 2, 3
Caster .....	21	Steering .....	20
Choke, Automatic .....	8	Transmission .....	15, 16
Circuit Breakers, Fuses .....	14	Rear Axle .....	1, 3, 17
Clearance, Ground .....	25	Regulator - Generator .....	10
Clutch - Pedal Operated .....	15	Rims .....	18
Coil, Ignition .....	11	Rings, Piston .....	4
Connecting Rods .....	4	Rods - Connecting .....	4
Cooling System .....	9	Shock Absorbers, Front & Rear .....	19
Crankcase Ventilation .....	7	Spark Plugs .....	11
Crankshaft .....	5	Speedometer .....	12
Cylinders and Cylinder Head .....	2	Springs - Front & Rear Suspension .....	20, 21
Dimension Definitions .....	34, 35, 36	Valve, Engine .....	6
Distributor - Ignition .....	11	Stabilizer (Sway Bar) - Front & Rear .....	20, 21
Electrical System .....	10, 11, 12, 13, 14	Starting Motor .....	10
Engine .....		Steering .....	20, 21
Bore, Stroke, Displacement, Type .....	1, 2	Suppression - Ignition, Radio .....	11
Compression Ratio .....	1, 2	Suspension - Front & Rear .....	19, 20, 21
Firing Order, Cylinder Numbering .....	2, 11	Switches .....	12
General Information, H.P. & Torque .....	1, 2	Tailpipe .....	7
Lubrication .....	6, 7	Thermostat, Cooling .....	9
Power Teams .....	3	Timing, Engine & Valve .....	5, 6, 11
Exhaust System .....	7	Tires .....	1, 18
Equipment Availability .....	32	Toe In .....	21
Fan, Cooling .....	9	Torque Converter .....	16
Filters - Engine Oil, Fuel System .....	7, 8	Torque - Engine, Rated .....	1, 2, 3
Frame .....	19	Transmission - Types .....	1, 3, 8, 15, 16
Front Suspension .....	19, 20	Automatic .....	1, 3, 8, 15, 16
Fuel, Fuel Pump, Fuel System .....	1, 2, 8	Manual & Overdrive .....	1, 3, 8, 15, 16
Fuel Injection .....	1, 8	Ratios .....	15, 16
Fuses, Circuit Breakers .....	14	Tread .....	1, 22
Generator and Regulator .....	10	Trunk Luggage Capacity .....	30
Glass .....	24, 32	Turning Diameter .....	20
Height (Lamps) .....	14	Unitized Construction .....	19
Headroom - Body .....	26, 27, 30	Universal Joints, Propeller Shaft .....	16, 17
Heights - Overall .....	1, 24	Valves - Intake & Exhaust .....	5, 6
Hood .....	23	Vibration Damper .....	5
Horns .....	12	Voltage Regulator .....	10
Horsepower - Brake, Taxable .....	1, 2, 3	Water Pump .....	9
Ignition System .....	11	Weights - Shipping, Curb .....	33
Inflation - Tires .....	18	Wheel Alignment .....	21
Instruments .....	7, 12	Wheelbase .....	1, 23
Kingpin (Steering Axis) .....	21	Wheels & Tires .....	18
Lamp Bulbs .....	13	Wheel Spindle .....	21
		Widths - Car & Body .....	1, 22
		Windshield .....	24, 32
		Windshield Wiper .....	12