

AMA Specifications – Passenger Car

The information contained herein is prepared, distributed by, and is solely the responsibility of the automobile manufacturing company to whose products it relates. Questions concerning these specifications should be directed to the manufacturer whose address is shown below. This uniform specification form was developed by the automobile manufacturing companies under the auspices of the Automobile Manufacturers Association.

MANUFACTURER Chevrolet Motor Division General Motors Corporation	CAR NAME Chevrolet (1200-1600-1800) (283 V-8)	
MAILING ADDRESS Chevrolet Engineering Center Box 7346 North End Station, Detroit 2, Mich.	MODEL YEAR 1963	ISSUED: 10/1/62 REVISED (e)

NOTES:

1. The Specifications herein are those in effect at date of compilation and are subject to change without notice by the manufacturer.
2. UNLESS OTHERWISE INDICATED:
 - a. Specifications apply to standard models without optional equipment. Significant deviations are noted.
 - b. Nominal design dimensions are used throughout these specifications.

TABLE OF CONTENTS

General Specifications 1	Drive Units 15	Rear Suspension 21	Body & Car - General 22
Engine - Mechanical 2	Brakes 18	Body Dimensions 22	Weights 33
Electrical 10	Front Suspension & Steering . . 19	Station Wagon 31	Index 37

BODY—TYPES AND STYLE NAMES—

Body type, number of passenger & style names; use manufacturer's code for series & body style.

283 Cu. In. V-8 Engine - 195 hp

Biscayne	1211	2-Door	Sedan - 6 Passenger
	1235	4-Door	Station Wagon - 6 Passenger
	1269	4-Door	Sedan - 6 Passenger
Bel Air	1611	2-Door	Sedan - 6 Passenger
	1635	4-Door	Station Wagon - 6 Passenger
	1645	4-Door	Station Wagon - 9 Passenger
	1669	4-Door	Sedan - 6 Passenger
Impala	1835	4-Door	Station Wagon - 6 Passenger
	1839	4-Door	Sport Sedan - 6 Passenger
	1845	4-Door	Station Wagon - 9 Passenger
	1847	2-Door	Sport Coupe - 5 Passenger
	1867	2-Door	Convertible - 5 Passenger
	1869	4-Door	Sedan - 6 Passenger

AMA Specifications – Passenger Car

MAKE OF CAR Chevrolet MODEL YEAR 1963 DATE ISSUED 10-1-62 REVISED (•) _____

POWER TEAMS

(Indicate whether standard or optional)

MODEL AVAILABILITY	ENGINE					TRANSMISSION	AXLE RATIO (Std. first)		
	Displ. cu. in.	Carburetor	Compr. Ratio	BHP @ RPM	Torque @ RPM		(a)		
1200-1600 (excluding sta. wagons)	283	2 bbl. down- draft	9.25:1	195 @ 4800	285 @ 2400	3-Speed Powerglide* Overdrive*	3.08:1 3.08:1	3.36:1 3.36:1	3.55:1 3.55:1 3.70:1
1800 and all station wagons	283	2 bbl. down- draft	9.25:1	195 @ 4800	285 @ 2400	3-Speed Powerglide* Overdrive*	3.36:1 3.36:1	3.55:1 3.55:1	3.55:1 3.70:1

* - Optional

(a) - Positraction options available in same ratio.

AMA Specifications—Passenger Car

Page 2

MAKE OF CAR Chevrolet MODEL YEAR 1963 DATE ISSUED 10-1-62 REVISED (e)

MODEL 1200-1600-1800 (V-8) 195 hp Engine

ENGINE—GENERAL

Type, no. cyls., valve arr.	90° OHV V-8	
Bore and stroke (nominal)	3.875 x 3.00	
Piston displacement, cu. in.	283	
Bore spacing (C/L to C/L)	4.4	
No. system (front to rear)	L. Bank	1-3-5-7
	R. Bank	2-4-6-8
Firing order	1-8-4-3-6-5-7-2	
Compres. ratio (nominal)	9.25:1	
Cylinder Head Material	Cast Alloy Iron	
Cylinder Block Material	Cast Alloy Iron	
Cylinder Sleeve—Wet, dry, none	None	
Number of mounting points	Front	Two
	Rear	One
Engine installation angle	5° 11'	
Taxable horsepower	Dia. ² x No. Cyl. 2.5	48
Published max. bhp* @ eng. RPM	195 @ 4800	
Published max. torque* (lb. ft. @ RPM)	285 @ 2400	
Recommended fuel regular - premium	Regular	
Idle speed (spec. neutral or drive)	Manual	500 in neutral
	Automatic	475 in drive

ENGINE—PISTONS

Material	Cast Aluminum Alloy		
Description and finish	Flat notched head, Slipper skirt		
Weight (piston only) oz.	20.30		
Clearance (limits)	Top land	.035 - .044	
	Skirt	Top	.0006 - .0010 (a)
		Bottom	-
Ring groove depth	No. 1 ring	.2153 - .2218	
	No. 2 ring	.2153 - .2218	
	No. 3 ring	.2093 - .2158	
	No. 4 ring	-	

* Max. bhp (brake horsepower) and max. torque corrected as defined by SAE Engine Test Code.

(a) Measured 2.44 from top of cylinder.

AMA Specifications—Passenger Car

MAKE OF CAR Chevrolet **MODEL YEAR** 1963 **DATE ISSUED** 10/1/62 **REVISED** (*)

MODEL 1200-1600-1800 (V-8) 195 hp Engine

ENGINE—CRANKSHAFT

Material		Forged Steel	
Vibration damper type		None	
End thrust taken by bearing (No.)		5	
Crankshaft end play		.002 - .006	
Main bearing	Material & type		
	Extra-life steel backed babbitt		
	Clearance		
	.0008 - .0034		
	Journal dia. and bearing overall length	No. 1	2.3009 x .752
		No. 2	2.3009 x .752
		No. 3	2.3009 x .752
		No. 4	2.3009 x .752
No. 5		2.3004 x 1.177	
No. 6		None	
No. 7		None	
Dir. & amt. cyl. offset		None	
Crankpin journal diameter		1.999 - 2.000	

ENGINE—CAMSHAFT

Location		In block above crankshaft	
Material		Cast alloy iron	
Bearings	Material	Extra-life steel backed babbitt	
	Number	5	
Gear or chain		Chain	
Crankshaft gear or sprocket material		Steel sprocket	
Type of Drive	Camshaft gear or sprocket material		
	Cast alloy iron		
	Timing chain	No. of links	46
		Width	.875
Pitch		.500	

ENGINE—VALVE SYSTEM

Hydraulic lifters (Std, opt, NA)		Standard
Valves' rotator, type (intake, exhaust)		None
Rocker ratio		1.5:1
Operating tappet clearance (indicate hot or cold)	Intake	Zero
	Exhaust	Zero
Timing marks on flywheel, damper, other		Crankshaft Pulley Hub

(Continued)

AMA Specifications – Passenger Car

MAKE OF CAR Chevrolet MODEL YEAR 1963 DATE ISSUED 10/1/62 REVISED (a)

MODEL 1200-1600-1800 (V-8) 195 hp Engine

ENGINE—RINGS

Function (top to bottom)	No. 1, oil or comp.	Compression
	No. 2, oil or comp.	Compression
	No. 3, oil or comp.	Oil Control
	No. 4, oil or comp.	None
Compression	Description - material, type, coating, etc.	Cast Alloy Iron, inside bevel Upper - Flash chrome plate Lower - Wear resistant coating
	Width	.0775 - .0730 Upper; .0770 - .0730 Lower
	Gap	.010 - .020
Oil	Description - material, type, coating, etc.	Multi-piece (2 rails and one spacer expander) Spacer-expander - steel Rails - Stainless steel, chromeplated O.D.
	Width	.1930 - .1950 (assembled)
	Gap	.015 - .055
Expanders		In oil ring assembly

ENGINE—PISTON PINS

Material		Chromium Steel
Length		2.990 - 3.010
Diameter		.9276 - .9273
Type	Locked in rod, in piston, floating, etc.	Locked in rod
	Bushing	None
		Material
Clearance	In piston	.00015 - .00025
	In rod	None
Direction & amount offset in piston		Major Thrust Side .060

ENGINE—CONNECTING RODS

Material		Drop Forged Steel
Weight (oz.)		20.00
Length (center to center)		5.699 - 5.701
Bearing	Material & Type	Extra-life steel backed babbitt - removable
	Overall length	.807
	Clearance (limits)	.0007 - .0027
	End play	.009 - .013

AMA Specifications – Passenger Car

MAKE OF CAR Chevrolet MODEL YEAR 1963 DATE ISSUED 10/1/62 REVISED (e)

MODEL 1200-1600-1800 (V-8) 195 HP Engine

ENGINE—LUBRICATION SYSTEM (cont.)

Oil pump type	Gear
Normal oil pressure (lb. @ engine rpm)	40 PSI @ 2000
Oil pressure sending unit (elect. or mech.)	Electric
Type oil intake (floating, stationary)	Stationary
Oil filter system (full flow, partial, other)	Full Flow
Filter replacement (element, complete)	Element
Capacity of crankcase, less filter-refill (qt.)	4
Oil grade recommended (SAE viscosity and temperature range)	32°F and above - SAE 20W, SAE 20 or SAE 10W-30 40°F and above - SAE 10W, or SAE 10W-30 50°F and below - SAE 5W, or SAE 5W-20
Engine Service Requirement (MM, MS, etc.)	MS or DG

ENGINE—EXHAUST SYSTEM

Type (single, single with cross-over, dual, other)	Single with crossover
Muffler No. & type (reverse flow, straight thru, separate resonator)	One: Reverse flow
Exhaust pipe dia. (O.D., wall thickness)	2.00 x .067-.083
	2.00 x .057-.069
Tail pipe diameter (O.D. & wall thickness)	1.875 x .062-.076

ENGINE—CRANKCASE VENTILATION SYSTEM

Type (ventilates to atmos., induction system, other)	Standard	Ventilates to induction system
	Optional	
Control unit	Make and model	AC5649996
	Location	At rear of carburetor
	Energy source (manifold vacuum, carburetor air stream, other)	Manifold vacuum
	Control method (variable orifice, fixed orifice, other)	Variable
Complete system	Discharges (to intake manifold, carb. air intake, air cleaner intake, other)	Intake manifold
	Air inlet (breather cap, carburetor air cleaner, other)	Breather Cap
	Flame arrestor (screen, check valve, other)	Check Valve

AMA Specifications—Passenger Car

MAKE OF CAR Chevrolet MODEL YEAR 1963 DATE ISSUED 10-1-62 REVISED ^(*)

MODEL 1200-1600-1800 (V-8) 195 HP Engine

ENGINE—VALVE SYSTEM (cont.)

*	Intake	Opens (^o BTC)	32° 30'	
		Closes (^o ABC)	87° 30'	
		Duration - deg.	300°	
	Exhaust	Opens (^o BBC)	74° 30'	
		Closes (^o ATC)	45° 30'	
		Duration - deg.	300°	
Valve opening overlap		78°		
Intake	Material		Carbon Steel	
	Overall length		4.902 - 4.922	
	Actual overall head dia.		1.715 - 1.725	
	Angle of seat & face		46° (seat) 45° (face)	
	Seat insert material		None	
	Stem diameter		.3404 - .3417	
	Stem to guide clearance		.0010 - .0033	
	Lift (@ zero lash)		.3987	
	Outer spring press. and length	Valve closed (lb. @ in.)	78-86 @ 1.660	
		Valve open (lb. @ in.)	170-180 @ 1.260	
	Inner spring press. and length	Valve closed (lb. @ in.)	Spring Damper	
		Valve open (lb. @ in.)	Spring Damper	
	Exhaust	Material		High Alloy Steel
		Overall length		4.913 - 4.933
Actual overall head dia.		1.495 - 1.505		
Angle of seat & face		46° (seat) 45° (face)		
Seat insert material		None		
Stem diameter		.0010 - .0027		
Stem to guide clearance		.0010 - .0027		
Lift (@ zero lash)		.3987		
Outer spring press. and length		Valve closed (lb. @ in.)	78-86 @ 1.660	
		Valve open (lb. @ in.)	170-180 @ 1.260	
Inner spring press. and length		Valve closed (lb. @ in.)	Spring Damper	
		Valve open (lb. @ in.)	Spring Damper	

ENGINE—LUBRICATION SYSTEM

Type of lubrication (splash, pressure, nozzle)	Main bearings	Pressure
	Connecting rods	Pressure
	Piston pins	Splash
	Camshaft bearings	Pressure
	Tappets	Pressure
	Timing gear or chain	Nozzle
	Cylinder walls	Pressure, jet cross sprayed

* - Including cam ramps

(Continued)

AMA Specifications – Passenger Car

MAKE OF CAR Chevrolet **MODEL YEAR** 1963 **DATE ISSUED** 10/1/62 **REVISED(s)** _____

MODEL _____ 1200-1600-1800 (V-8) 195 HP Engine

ENGINE—COOLING SYSTEM

Type system (pressure, pressure-vented, atmospheric, other)		Pressure
Radiator cap relief valve pressure		13 PSI ±PSI
Circulation Type (choke, bypass)		Choke
Thermostat Starts open-at (°F)		177° - 183°F
Type (centrifugal, other)		Centrifugal
GPM @ 1000 pump rpm		53 GPM @ 4200 RPM
Water pump Number of pumps		One
Drive (V-belt, other)		V-Belt
Sealing type		Double row ball
By-pass circulation type (external, internal)		Internal
Radiator core type (cellular, tube-and-fin, other)		Tube on center
Cooling system capacity	With heater (qt.)	18.5
	Without heater (qt.)	17.5
	Dist. equipment capacity (qt.)	18.5
Water jacket full length of cylinder (yes, no)		Yes
Water all around cylinder (yes, no)		Yes
Radiator hose	Number and type (molded, straight)	One molded
	Tube diameter	1.75
	Number and type (molded, straight)	One molded
	Tube diameter	1.50
	Number and type (molded, straight)	None
	Tube diameter	None
Fan	Number of blades & Spacing	4 - staggered
	Diameter	17.62
	Ratio fan to crankshaft rev.	.949:1
	Fan output type	5-blade 18" fan used with air conditioning
	Sealing type	Double row ball
* Drive belts (indicate belt used by letter)	Generator	A
	Water Pump	A
	Power Steering	B
	Air Conditioning	C

* Drive Belt Dimensions	A	B	C
Angle of V	37-44°	37-44°	37-44°
Nominal length (SAE)	56.50	35.00	55.50
Width	.380 ± .005	.380 ± .005	.380 ± .005

AMA Specifications— Passenger Car

MAKE OF CAR Chevrolet MODEL YEAR 1963 DATE ISSUED 10-1-62 REVISED (a)

MODEL 1200-1600-1800 (V-8) 195 HP Engine

ENGINE—FUEL SYSTEM

(See Supplement to Page 8 for Details of Fuel Injection, Supercharger, etc. if used)

Induction type: Carburetor, fuel injection, supercharger.		Carburetor	
Fuel Tank	Capacity (gals.)	20 (19 on station wagons)	
	Filler location	Left rear quarter panel	
Fuel Pump	Type (elec. or mech.)	Mechanical	
	Location	Lower right front corner of engine	
	Pressure range	5.25 - 6.50 PSI	
Vacuum booster (std., optional, none)		None	
Fuel Filter	Type	Fine mesh plastic strainer in gasoline tank	
	Location	and sintered bronze filter in carburetor	
Carburetor	Choke type	Automatic	
	Intake manifold heat control (exhaust or water)	Exhaust	
	Air circ. type	Standard	Paper Element
		Optional	

CARBURETOR SUPPLEMENTARY INFORMATION

Model Usage	Engine Displ.	Transmission	Carburetors		No. Used and Type	Barrel Size
			Make	Model		
12-16-1800	283	Synchronesh Powerglide	Rochester	7023007	One; Two bbl. down-draft	1.4375
			Rochester	7023008		

AMA Specifications – Passenger Car

MAKE OF CAR Chevrolet MODEL YEAR 1963 DATE ISSUED 10-1-62 REVISED (*)

MODEL 1200-1600-1800 (V-8) 195 HP Engine

ELECTRICAL—STARTING SYSTEM (cont.)

Motor Drive	Engagement type		Solenoid
	Pinion meshes (front, rear)		Rear
	Number of teeth	Pinion	9
		Flywheel	153
	Flywheel tooth face width		.4135

ELECTRICAL—IGNITION SYSTEM

Coil	Make		Delco-Remy
	Model		1115115
	Amps	Engine stopped	1.0
Engine idling		1.8	
Distributor	Make		Delco-Remy
	Model		1111015
	Cent'fgal adv. in crankshaft degrees @ engine rpm (nominal)	Start (rpm)	800
		Intermediate points deg. @ rpm	
		Max deg. @ rpm	32 @ 4000
	Vacuum adv. in crankshaft degrees @ in. Hg. (nominal)	Start (in Hg)	
		Intermediate points, deg @ in Hg	
		Max. deg. in. Hg.	
	Breaker gap (in.)		.019
	Cam angle (deg.)		28° - 32°
Breaker arm tension (oz.)		19 - 23 oz.	
Timing	Crankshaft deg. @ rpm.		3° - 5° BTC @ 550.
	Mark location		Crankshaft Pulley Hub
	Cylinder numbering system (see page 2)		Left bank 1-3-5-7
			Right bank 2-4-6-8
Firing order (see page 2)		1-8-4-3-6-5-7-2	
Spark Plug	Make and model		AC 45
	Thread (mm)		14
	Tightening torque (lb. ft.)		25
	Gap		.033 - .040
Cable	Conductor type		Linen core impregnated with electrical conducting material
	Insulation type		Rubber with neoprene jacket
	Spark plug protector		Hypalon jacket

ELECTRICAL—SUPPRESSION

Locations & type	Non-Metallic High Tension Ignition Cables
------------------	---

AMA Specifications – Passenger Car

MAKE OF CAR Chevrolet MODEL YEAR 1983 DATE ISSUED 10-1-62 REVISED (*)

MODEL 1200-1600-1800 (V-8) 195 HP Engine

ELECTRICAL—SUPPLY SYSTEM

Battery	Make and Model		Delco 1980554	
	Voltage Rtg. & Total Plates		12 Volt, 54 Plate	
	SAE Designation & Amp Hr. Rtg		44 amp hr. @ 20 hr. rate	
	Location		Right front of engine compartment	
Terminal grounded		Negative		
Generator	Make		Delco-Remy	
	Model		1100628	
	Type		Diode rectified	
	Ratio—Gen. to Cr/s rev.		2.30:1	
	Gen. cut-in (hot)—engine rpm		Idle (435 RPM)	
Regulator	Make		Delco-Remy	
	Model		1119512	
	Type		Vibrator	
	Cutout relay	Closing voltage @ generator rpm	None	
		Reverse current to open		
	Regulated	Voltage	13.8 - 14.8 @ 85°F	
		Current	-	
Voltage test conditions	Temperature	Operating		
	Load	3-8 Amperes		
	Other	None		

ELECTRICAL—STARTING SYSTEM

Starting motor	Make		Delco-Remy	
	Model		1107237	
	Rotation (drive end view)		Clockwise	
	Engine cranking speed			
	Test conditions		Engine at operating temperature	
	Lock test	Amps		
		Volts		
		Torque (lb. ft.)		
No load test	Amps	49-76		
	Volts	10.6		
	RPM (min.)	6200 - 9400		
Motor control	Switch (solenoid, manual)		Solenoid	
	Starting procedure		<p>Synchromesh - Place gearshift in neutral and depress clutch to floor.</p> <p>Powerglide - Place control lever in N or P position.</p> <p>Initial Start - Press accelerator pedal to floor once to set automatic choke, then release. Turn ignition to START and release as soon as engine starts.</p>	

(Continued)

AMA Specifications – Passenger Car

MAKE OF CAR Chevrolet **MODEL YEAR** 1963 **DATE ISSUED** 10-2-62 **REVISED** (e)
MODEL 12-16-1800 Standard V-8

ELECTRICAL—LAMP BULBS

Give quantity used and trade number, e.g., Headlamp 2-5400 S, dual headlight 2-4001, 2-4002. Indicate accessories which are not standard equipment by an asterisk following the numbers.

Headlamps & arrangement	Horizontal, dual; 2-4002 (outer), 2-4001 (inner)	
Headlamp beam indicator	1-57	
Parking	2-1034 (4CP filament)	
Tail (a)	2 and 4-1034 (4CP filament); tail only, 2-67	
Stop (a)	2 and 4-1034 (32CP filament)	
Direction signal	Front	2-1034 (32CP filament)
	Rear (a)	2 and 4-1034 (32CP filament)
	Indicator	2-57
License plate	1-67	
Instrument	See below	
Ignition lock	None	
Back up (b)	2-1073*	
Dome	Roof center, 1-211; rear qtr., 2-90 (1847); side rail, 2-90 (1839)	
Clock (b)	2-57*	
Radio	1-1893*	
Glove compartment (c)	1-57*	
Balance of instrument cluster	fuel gauge, 1-57; generator, indicator, 1-57; oil pressure indicator, 1-57; speedo. head, 3-57; temperature indicator, 2-57.	
Compass	1-53*	
Courtesy (e)	Rear qtr.: 1-90 (16-1845); instru. panel, 2-89 (1847-67); seat console, 2-90 (1847-67)*	
Heater (and all weather air conditioner)(d)	1-53*	
Luggage compartment (§)	1-93*	
Parking brake flasher (b)	1-257*	
Powerglide quadrant	1-53*	
Seat console compartment (e)	1-57*	
Spotlamp:		
Inside operated	1-4405*	
Portable	1-4416*	
Tach. gage	1-53*	
Traffic hazard flasher	1-53*	
Underhood	1-93*	

(a) 2 tail, stop and turn for 1200 series; 2 tail, stop and turn, and 2 tail only for 1600 series; 4 tail, stop and turn for 1800 series.

(b) Std. for 1800 series.

(c) Std. for 16 and 1800 series.

(d) Air conditioner optional equipment.

(e) Seat console optional equipment.

(§) Std for 1800 except station wagons.

AMA Specifications – Passenger Car

MAKE OF CAR Chevrolet MODEL YEAR 1963 DATE ISSUED 7-2-62 REVISED (e)

MODEL 12-16-1800 Standard V-8

ELECTRICAL—INSTRUMENTS AND SWITCHES

Speed-ometer	Make	AC
	Trip odometer (yes, no)	NO
Charge indicator—type		Tell-tale lamp
Temperature indicator—type		Tell-tale lamps (cold, green; hot, red)
Oil pressure indicator—type		Tell-tale lamp
Fuel indicator—type		Electric, gauge
Other		Parking brake flasher (a)
Ignition switch	Identify positions in order and circuits controlled	2nd position CCW from vertical - ACC (accessories) 1st position CCW from vertical - LOCK (off, locked) Vertical - OFF (unlocked) 1st position CW from vertical - ON (ignition, batt., access.) 2nd position CW from vertical - START (ignition, batt., accessories, starter; spring return to ON)
	Provision for illumination	Lamp from instru. cluster
	Location	Instru. panel to right of steering column
Main lighting switch	Identify positions and lamps controlled	Fully depressed - off 1st notch - Instru. panel, parking, tail and license lamps 2nd notch - Instru. panel, head, tail and license lamps CW rotation of knob - dim and turn off instru. panel lamps CCW rotation of knob - turn on and brighten instru. panel lamps; Full CCW rotation - turn on dome lamp
Other light switches	Locations and lamps controlled	Toe panel - Head lamp dimmer Glove compartment - Glove comp. lamp (b) Front door hinge pillar - Dome and courtesy lamps (b) Steering column - Turn signal lamps Under instru. panel - Stop lamps Steering mast jacket - Back-up lamps (a) Console compartment - Console compartment light (c)
Other switches	Locations and devices controlled	Accelerator linkage - Overdrive kick-down (d) Instru. panel to right of steering column - Heater blower Doors or qtr. trim panels - Power windows (d) Instru. panel, center - Radio (d) Instru. panel, left of steering column - W/S wiper Instru. panel, left of steering column - Tailgate window (g) Steering column - Trans. Neu. Saf. Sw. (z) Front seat lower panel, L.H. side - Power seat (h) Under instru. panel to left of steering column - Power top (j)
Windshield wiper	Make	Delco
	Type	Electric, Single-speed (e)
	Vacuum booster provision	None
	Washer provision	None (f)
Horn	Type	Vibrator
	Number used	2
	Amp draw (each)	8.00-11.0 @ 12.5 V

- | | |
|--|--|
| <p>(a) Std. on 1800 series
 (b) Std. on 16 and 1800 series
 (c) Std. on SS models (1847-67)
 (d) Optional equipment
 (e) Optional electric two-speed including washer
 (f) Optional dealer installed accessory, pushbutton</p> | <p>(g) Standard on 16-1845
 (h) Optional on 16-1800 Series
 (j) Standard on 1867</p> |
|--|--|

AMA Specifications – Passenger Car

Page 14f

MAKE OF CAR Chevrolet MODEL YEAR 1963 DATE ISSUED 10/1/62 REVISED (a)

SUPPLEMENTARY INFORMATION

MODEL 1100 - 1500 - 1700 (6-cylinder)

Luggage compartment lamp	(b)
Seat console compartment lamp	(c)
Underhood lamp	SAE-9
Spotlamp (inside operated)	AGC-15
Overdrive solenoid	AGC-15
Windshield wiper motor	
Single- speed	SAE-20
Two- speed	SAE-20 and 14 C.B.
Hydraulic fold ing top motor	40C. B.
Power seats	40C. B.
Power windows	40C. B.
Tailgate wiper	40C. B.

AMA Specifications – Passenger Car

MAKE OF CAR Chevrolet MODEL YEAR 1963 DATE ISSUED 10-1-62 REVISED (*)

MODEL 12-16-1800 Standard V-8

ELECTRICAL—FUSE & CIRCUIT BREAKER DATA

Use trade number of fuse, e.g., SFE-10. Indicate circuit breaker by ampere capacity suffixed by letters "C.B.", e.g., 30 C.B. Where fuse or circuit breaker protects multiple circuits indicate first use by a letter and repeat the same letter for all units protected by the same fuse or circuit breaker, e.g., Parking lamp SFE-10 (a), Direction indicator same as (a).

Headlamp	15 C. B. (a)
Headlamp beam indicator	(a)
Parking lamp	(a)
Tail lamp	AGC-15 (b)
Stop lamp	(b)
Direction indicator	Interrupter
License plate lamp	(b)
* Instrument lamp	AGC-3 (c)
Ignition lamp	None
Back up lamp	AGC-10 (d)
Dome lamp	(b)
Clock	(b)
Clock lamp	(c)
Radio and radio dial lamp	AGC-2.5
Glove compartment lamp	(b)
Direction lamp	Interrupter
Heater	(d)
Park, brake flasher	(d)
Courtesy lamps	(b)
Traffic hazard flasher	(b)
Heater (and A/C) control lamp	(c)
Powerglide quadrant lamp	(c)
Compass lamp	(c)
* Speedo, head, temperature indicators, fuel gauge, generator indicator, oil pressure indicator	

ELECTRICAL—LOCATION OF OUTSIDE LAMPS

	Tail	Lowest	26.0	
		Highest	26.0	
Height above ground to center of bulb	Stop		26.0	
	Backup		26.0	
	License, rear		23.0	
	Directional	Front		21.5
		Rear		26.0
	Headlamp	Inside		26.0
		Outside*		26.0
	Distance from C/L of car to center of bulb	Tail	Inside	16.0 Impala, 23.5 Biscayne, Bel Air
			Outside	30.5
		Stop		16.0 Impala, 23.5 Biscayne, Bel Air
Backup			23.5	
License, rear			On centerline	
Directional		Front		27.0
		Rear		16.0 Impala, 23.5 Biscayne, Bel Air
Headlamp		Inside		23.0
		Outside*		31.5

* If single headlamps are used enter here.

AMA Specifications – Passenger Car

MAKE OF CAR Chevrolet MODEL YEAR 1963 DATE ISSUED 10/1/62 REVISED (e)

MODEL 12-16-1800 Standard V-8

DRIVE UNITS—MANUAL TRANSMISSION WITH OVERDRIVE

For transmission data see manual transmission section

Overdrive	Type (planetary or other)		Planetary
	Manual lockout (yes, no)		Yes
	Downshift accelerator control (yes, no)		Yes
	Minimum cut-in speed		27 MPH
	Gear ratio		0.70:1
Lubricant	Capacity (pt.) (Overdrive only)		1
	Separate filler (yes, no)		No
	Type recommended		Military MIL-L-2105-B
	SAE viscosity number	Summer	---
		Winter	---
Ext. cold		---	

DRIVE UNITS—AUTOMATIC TRANSMISSION

Trade name	Powerglide	
Type describe	Torque Converter with Planetary Gears	
Method of Selection (Lever, Push Button or other)	Lever	
Selector Pattern	P-R-N-D-L	
List gear ratios Selector Pattern and indicate which are used in each selector position	D, 1.82 and 1.0:1 L, 1.82:1 R, 1.82:1	
Max. upshift speeds—drive range	63 mph	
Max. kickdown speeds—drive range	60 mph	
Torque converter	Number of elements	3
	Max. ratio at stall	2.10:1
	Type of cooling (air, water)	Water
Lubricant	Capacity—refill (pt.)	3
	Type recommended	A suffix A
Special transmission features		

DRIVE UNITS—PROPELLER SHAFT

Number used	2		
Type (exposed, torque tube)	Exposed		
Outer diameter x length* x wall thickness	Manual transmission	Front	2 x 30.1 x .10
		Rear	2 x 35.0 x .10
	Overdrive transmission	Front	2 x 25.0 x .10
		Rear	2 x 35.0 x .10
	Automatic transmission	Front	2 x 27.2 x .10
		Rear	2 x 35.0 x .10

*Center to center of universal joints, or to centerline of rear attachment.

(Continued)

AMA Specifications – Passenger Car

MAKE OF CAR Chevrolet MODEL YEAR 1963 DATE ISSUED 10/1/62 REVISED (a)

MODEL 12-16-1800 Standard V-8

DRIVE UNITS—CLUTCH (Manual Transmission)

Make & type		Chevrolet, Single Drive Drive
Type pressure plate springs		Diaphragm
Effective plate pressure (lb.)		1700 - 1850
No. of clutch driven discs		One with 2 facings
Clutch facing	Material	Woven Asbestos
	Outside & inside dia.	10.0 and 6.0 (a)
	Total off. area (sq.in.)	100.54 (b)
	Thickness	.135 in.
	Engagement cushioning method	Flat Spring Cushions
Release bearing	Type & method of lubrication	Ball Bearing, Prepacked, Sealed
Torsional damping	Methods: springs, friction material	Coil Springs in Driven Disk Assembly

DRIVE UNITS—TRANSMISSIONS

Manual (std. or opt.)	3-Speed, Standard
Manual with overdrive (std. or opt.)	Optional
Automatic (std. or opt.)	Optional

DRIVE UNITS—MANUAL TRANSMISSION

Number of forward speeds		3	
Transmission ratios	In first	2.94:1	
	In second	1.68:1	
	In third	1.0:1	
	In fourth	---	
	In reverse	3.34:1	
Synchronous meshing, specify gears		2nd and 3rd	
Shift lever location		Steering Column	
Lubricant	Capacity (qt.)	2 (c)	
	Type recommended	Military MIL-L-2105-B	
	SAE viscosity number	Summer	---
		Winter	---
		Extreme cold	---

- (a) For overdrive, 10.0 and 6.5
- (b) For overdrive, 90.72
- (c) For overdrive, 3

AMA Specifications - Passenger Car

MAKE OF CAR Chevrolet MODEL YEAR 1963 DATE ISSUED 10/1/62 REVISED (a)

MODEL 12-16-1800 Standard V-8

DRIVE UNITS—WHEELS

Type & material		Short Spoke Disk, Steel
Rim (size and flange type)	Std.	14 x 5J (a)
	Opt.	15 x 5K
Attachment	Type (bolt or stud)	Stud
	Circle diameter	4.75
	Number and size	5 Hex Nuts, 7/16 - 20

DRIVE UNITS—TIRES Tubeless, 2 Ply Construction, unless indicated otherwise

Standard (List option below)	Size & ply	7.00 x 14-4 PR except Conv., 7.50 x 14-4 PR, & Wagons, 8.00 x 14-4 PR
	Type - Nylon, etc.	Blackwall Rayon
	Rev/mile at 50 mph.	7.00 x 14-4 PR, 817; 7.50 x 14-4 PR, 800; 8.00 x 14-4 PR, 785
Inflation press. (cold)	Front	24
	Rear	24 PSI except Wagons, 28 PSI
Optional tires - size and ply		7.00 x 14-4 PR, W/Wall, Highway Rayon; 7.50 x 14-4 Ply, B/Wall, Highway Nylon; 7.50 x 14-4 Ply, W/Wall, Highway Nylon; 7.50 x 14-4 PR, W/Wall, Highway Rayon; 7.50 x 14-6 Ply, B/Wall, Highway Rayon; 7.50 x 14-4 PR, B/Wall, Highway Rayon; Con't. in footnote (b)

BRAKES—SERVICE

		Regular Production	Metallic Brakes
Type (duo-servo, disc, balanced, etc.)		Duo-Servo, 4-Wheel Hydraulic	
Self adjusting (std., opt., N.A.)		Standard	
Hydraulic system type (single, dual, etc.)		Single	
Power brake make & type (remote, integral, etc.)		Delco-Soraine, Vacuum Power Unit Assisting Master Cylinder; integral	
Effective area (sq. in.)*		186.2	134.9
Gross lining area (sq. in.)**		200.4	134.9
Swept drum area (sq. in.)***		328.0	
Percent brake effectiveness—front		58.5	
Drum	Front	11.0	
	Rear	11.0	
Type and material		Composite: Rim, Cast Iron Alloy; Web, Steel	
Wheel cylinder bore	Front	1.1875 (c)	
	Rear	1.0 (c)	
Master cylinder bore		1.0 (c)	.875 (c)
Available pedal travel			
Line pressure at 100 lb. pedal load		750 PSI	
Shoe clearance adjustment		Self-Adjusting	

(Continued)

* Excludes rivet holes, grooves, chamfers, etc.
 ** Includes rivet holes, grooves, chamfers, etc.
 *** Total swept areas for four brakes
 Widest lining contact width for each brake x its drum circumference.

- (a) 14 x 6 JK for Station Wagons
- (b) 8.00 x 14-4 Ply, B/Wall, Highway Rayon; 8.00 x 14-4 Ply, B/Wall, Highway Nylon; 8.00 x 14-4 PR, W/Wall, Highway Rayon; 6.70 x 15-4 Ply, B/Wall, Highway Rayon; 6.70 x 15-4 Ply, B/Wall, Highway Nylon; 6.70 x 15-4 Ply, B/Wall, Highway Rayon, Tube; 6.70 x 15-4 Ply, B/Wall, On-Off, Rayon, Tube; 6.70 x 15-4 Ply, B/Wall, Highway Nylon, Tube; 6.70 x 15-6 Ply, B/Wall, Highway Rayon; 7.10 x 15-4 Ply, B/Wall, Highway Rayon; 7.10 x 15-4 Ply, B/Wall, Highway Nylon.
- (c) With Power brakes also.

AMA Specifications – Passenger Car

MAKE OF CAR Chevrolet MODEL YEAR 1963 DATE ISSUED 10/1/62 REVISED (*)

MODEL 12-16-1800 Standard V-8

DRIVE UNITS—PROPELLER SHAFT (cont.)

Inter-mediate bearing	Type (plain, anti-friction)	Single Row Ball, Sealed
	Lubrication (fitting, prepack)	Prepack
Universal joints	Make	Chevrolet
	Number used	3
	Type (ball and trunion, cross, other)	Cross
	Bearing	Type (plain, anti-friction)
Lubric. (fitting, prepack)		Prepack
Drive taken through (torque tube or arms, springs)		Upper and Lower Control Arms
Torque taken through (torque tube or arms, springs)		Upper and Lower Control Arms

DRIVE UNITS—REAR AXLE

Description (see instructions)		Conventional - Semi-Floating, Overhung Pinion Gear	
Limited Slip differential, type		Conventional with Dual Disk Clutches	
Drive Pinion Offset		1.5	
No. of differential pinions		Conventional 2; Limited Slip, 4	
Gear ratios (Std. equip.)	Manual transmission	12 and 1600 Sedans, 3.08:1 Station Wagons and 1800 Models, 3.36:1	
	Overdrive transmission	3.70:1	
	Automatic transmission	Same as "Manual"	
Ring gear O.D. (std. ratio)		8.375	
Pinion adjustment (shim, other)		Shim	
Pinion bearing adj. (shim, other)		None	
Wheel bearing type		Single Row Ball, Sealed	
Lubricant	Capacity (pt.)	4	
	Type recommended	Military MIL-L-2105-B	
	SAE viscosity number	Summer	---
		Winter	---
Extreme cold		---	

REAR AXLE RATIO TOOTH COMBINATIONS

(See page 3 for axle ratio usage)

Axle ratio		3.08:1	3.36:1	3.70:1
No. of teeth	Pinion	12	11	10
	Ring gear	37	37	37

AMA Specifications – Passenger Cars

MAKE OF CAR Chevrolet MODEL YEAR 1963 DATE ISSUED 10/1/62 REVISED (*)

MODEL 12-16-1800 Standard V-8

SUSPENSION FRONT (cont.)

Spring	Type	Coil
	Material	Steel Alloy
	Size (coil design height & I.D.; bar length & dia.)	10.50 and 3.802 141.25 x .630
	Spring rate (lb. per in.)	275
	Rate at wheel (lb. per in.)	1880
Stabilizer	Type (link, linkless, frameless)	Link
	Material & bar diameter	Steel and 0.6875

STEERING

Mechanical (std., opt., NA)	Standard		
Power (std., opt., NA)	Optional		
Wheel diameter	17.00		
Turning diameter	Outside front	Wall to wall (l. & r.) 44.1 ft.	
		Curb to curb (l. & r.) 40.8 ft.	
	Inside rear	Wall to wall (l. & r.) 24.2 ft.	
		Curb to curb (l. & r.) 24.5 ft.	
Outside wheel angle with inside wheel at 20°			
Mechanical	Type	Semi-Reversible, Recirculating Ball	
	Gear	Make	Saginaw
		Ratios	Gear 24.0:1
		Overall	28.0:1
	No. wheel turns	5.80 Lock to Lock	
Power	Type (coil, linkage, etc.)	Hydraulically operated Cylinder to Linkage	
	Make	Saginaw	
	Trade name	--	
Power	Type	Semi-Reversible, Recirculating Ball	
	Gear	Gear	20.0:1
		Overall	24.0:1
		Pump driven by	Crankshaft Pulley
	Number wheel turns	5.06 Lock to Lock	
Linkage	Type	Relay	
	Location (front or rear of wheels, other)	Front	
	Drag link (trans. or longit.)	None	
	Tie rods (one or two)	Two	

(Continued)

AMA Specifications—Passenger Car

MAKE OF CAR Chevrolet MODEL YEAR 1963 DATE ISSUED 10/1/62 REVISED (u)

MODEL 12-16-1800 Standard V-8

BRAKES—SERVICE (cont.)

	Bonded or riveted		Bonded	Welded	
	Material		Molded Asbestos	Sintered Iron	
Brake lining	Front Shoe	Size (length x width x thickness)	Front wheel	9.34 x 2.75 x .168	1.64 x 1.37 x .175
			Rear wheel	9.34 x 2.00 x .168	2.00 x 1.00 x .175
		Segments per shoe	1	6	
	Rear Shoe	Size (length x width x thickness)	Front wheel	11.75 x 2.75 x .168	1.64 x 1.37 x .295
			Rear wheel	11.75 x 2.00 x .168	2.00 x 1.00 x .295
		Segments per shoe	1	Front, 12; Rear, 10	

BRAKES—PARKING

Type of control	Foot Pedal for apply, "T" Handle for release	
Location of control	Below Instrument Panel, Left of Steering Column	
Operates on	Rear Service Brakes	
If separate from service brakes	Type (internal or external)	Not Separate
	Drum diameter	---
	Lining size (length x width x thickness)	---

FRAME or UNITIZED CONSTRUCTION

Type and description All welded "X" frame with box girder side rails, box section front suspension crossmember, "Z" section intermediate crossmember, channel section rear crossmember and reinforced box girder center beam. Special crossmember for rear suspension upper control arms/mounting.

SUSPENSION—GENERAL (See Supplemental page 19 for details on Air Suspension)*

Provision for car leveling	Front Stabilizer Bar	
Provision for brake dip control	Mounting Angle of Front Upper Control Arms	
Provision for acc. squat control	Geometry of Rear Suspension Control Arms	
Special provisions for car jacking	None	
Shock absorber front & rear	Type	Direct, Double Acting, Hydraulic
	Make	Delco
	Piston dia.	1.00
Other special features	----	

SUSPENSION—FRONT

Type and description	Independent, wheels spherically-jointed to frame-hinged upper and lower control arms. Frame-secured coil spring and shock absorber (inside coil spring) attached to lower control arm.
----------------------	--

* Air Suspension: Normal operating pressures
 Air spring type spring rates
 Compressor data leveling data
 type
 make
 drive ratio

(Continued)

AMA Specifications – Passenger Car

MAKE OF CAR Chevrolet MODEL YEAR 1963 DATE ISSUED 10/2/62 REVISED (a)

MODEL 12-16-1800 Standard V-8

STEERING (cont)

Steering Axis	Inclination at camber (deg.)		
	Bearings (type)	Upper	Spherical Joint, Non-Metallic Bearing Liner
		Lower	Spherical Joint, Non-Metallic Bearing Liner
	Thrust	None	
Wheel alignment (range and preferred)	Caster (deg.)		(+) 0° ±30' (curb)
	Camber (deg.)		(+) 0° 30' ±30' (curb)
	Toe-in (outside tread-inches)		1/16 to 3/16 (overall, curb)
Steering spindle & joint type			Knuckle with Brake Cyl. Mount. Pad; Det. Steering Arms
Wheel spindle	Diameter	Inner bearing	1.2493 - 1.2498
		Outer bearing	.7492 - .7497
	Thread size		3/4 - 20 NEF-3
	Bearing type		Taper Roller

SUSPENSION—REAR

Type and description			4 Link; 3 Control Arms and a Lateral Control Bar			
Drive and torq. taken through (see page 17)			Control Arms			
Spring	Type		Coil			
	Material		Steel Alloy			
	Size (length x width, coil design height and I.D.; bar length & dia.)		9.88 and 3.638 138.27 and .583			
	Spring rate (lb. per in.)		230			
	Rate at wheel (lb. per in.)					
	Design load (lb. at design height)		1520			
	Mounting insulation type		None			
	If leaf	No. of leaves		Does not apply		
		Inserts	Type and size			
			Material			
Shackle (comp. or tens.)						
Stabilizer	Type (link, linkless, frameless)					
	Material					
Track bar type			Lateral, Frame to Rear Axle			

MAKE OF CAR Chevrolet MODEL YEAR 1963 DATE ISSUED 10-1-62 REVISED (*)

CAR AND BODY DIMENSIONS—GENERAL

NOTE: Included in the dimension definitions listed on pages 34-36 are those which have been adopted by SAE. These are indicated by a number following the type of dimension, e.g., L3. Additional dimensions have been added by the AMA Specifications Review Committee. These are shown by an additional letter, e.g., H67a. The symbol "a" has been added as a suffix to denote a dimension adopted by the AMA and submitted to the SAE for approval. The dimensions are developed from the following basic points:

1. Body dimensions are for all body styles.
2. All interior dimensions are taken with manikin 15.0 inches outboard of car centerline unless otherwise stated.
3. All interior dimensions are measured with the front seat in the lowest and rearmost position.
4. Unless otherwise specified, all exterior height dimensions are taken with a full design load which consists of 5 passengers, 300 lbs. front, 450 lbs. rear; includes spare wheel, tire and tools, and full complement of gas, oil, water and tires to recommended pressure, etc.
5. The SAE manikin with 90th percentile leg length will be used for recording purposes.
6. The H Point is the pivot center of the manikin's torso and thigh.
7. The Torso Line is a line parallel to the small of manikin's back and extending through the H Point.

EXTERIOR WIDTH DIMENSIONS

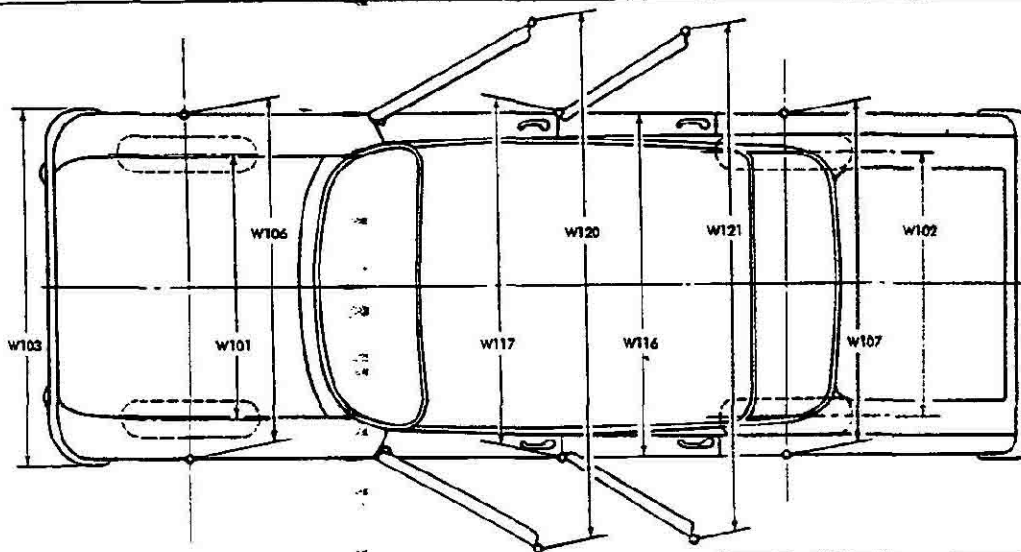

MODEL Chevrolet	Ref. No.	Sedans	Coupe	Convertible	Station Wagon
Tread - front	W101	-	-	60.3	-
Tread - rear	W102	-	-	59.3	-
Maximum overall car width	W103	-	-	79.0	-
Maximum overall body width	W116	-	-	76.0	-
Maximum body width at #2 pillar	W117	-	-	76.5	-
Front fender overall width	W106	-	-	76.4	-
Rear fender overall width	W107	-	-	77.0	-
Maximum overall car width - front doors open	W120a	141.6	-	156.6	141.6
Maximum overall car width - rear doors open	W121a	139.1	-	-----	139.1

AMA Specifications - Passenger Car

MAKE OF CAR Chevrolet MODEL YEAR 1963 DATE ISSUED 10-1-62 REVISED (e)

EXTERIOR HEIGHT DIMENSIONS

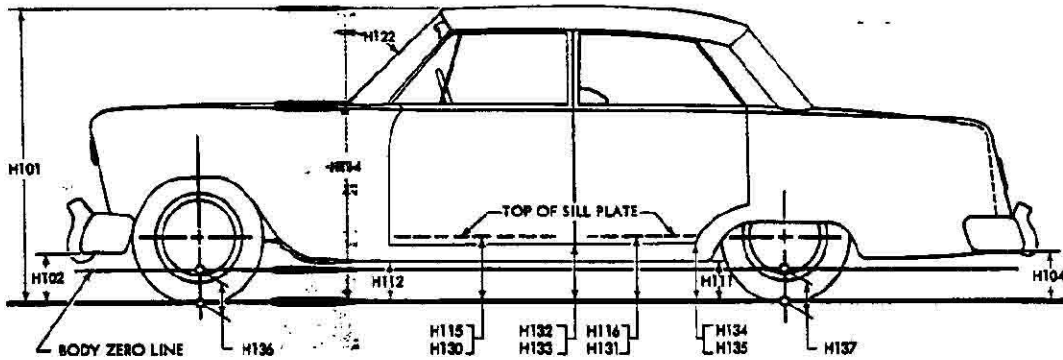

MODEL Chevrolet	Ref. No.	Station Wagon	Coupe	Convertible	Station Wagon
Overall height	H101	55.5	54.5	55.0	56.0
Hood at rear to ground	H114			38.0	
Rocker panel to ground - front	H112a			8.5	
Rocker panel to ground - rear	H111			8.0	
Step height - front (design load)	H115			13.0	
Step height - rear (design load)	H116	13.0			13.0
Step height - front (curb load)	H130			15.0	
Step height - rear (curb load)	H131	15.0			15.0
Bottom of door to ground, open - front	H132			13.0	
Bottom of door to ground, closed - front	H133			11.5	
Bottom of door to ground, open - rear	H134	11.5			11.5
Bottom of door to ground, closed - rear	H135	11.5			11.5
Front bumper to ground	H102		12.5	13.0	13.5
Rear bumper to ground	H104		12.0	12.5	13.0
Windshield slope angle	H122			55°	
Body zero to ground - front	H136a			5.0	
Body zero to ground - rear	H137a			5.0	

AMA Specifications – Passenger Car

MAKE OF CAR Chevrolet MODEL YEAR 1963 DATE ISSUED 10-1-62 REVISED(+) _____

EXTERIOR LENGTH DIMENSIONS

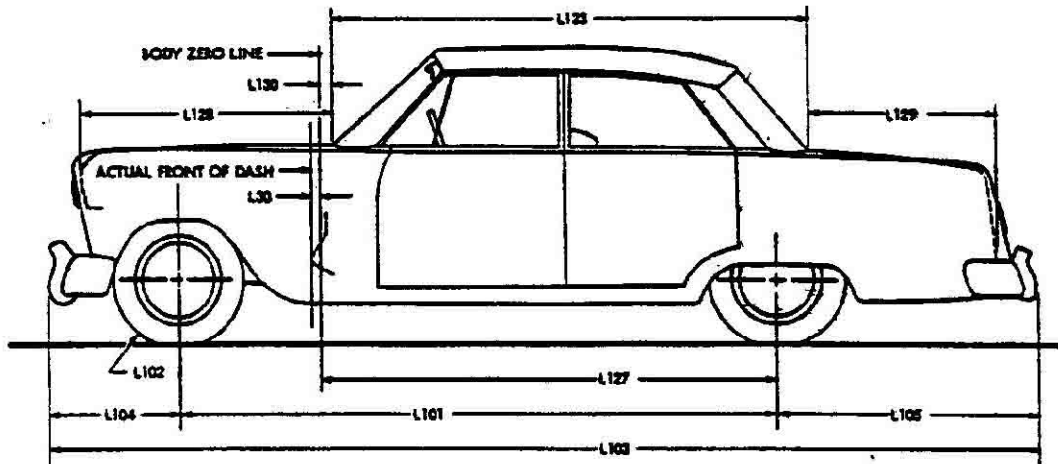

MODEL Chevrolet	Ref. No.	Sedans	Coupe	Convertible	Station Wagon
Body zero line to actual front of dash	L30			.5	
Wheelbase	L101			119.0	
Overhang - front	L104			33.4	
Overhang - rear	L105			58.0	
Overall length	L103			210.4	
Hood length at car centerline	L128a			50.6	
Body upper structure length at car centerline	L123	102.8	103.2	105.4	141.0
Deck length at car centerline	L129a	48.5		46.0	---
Body zero line to centerline of rear wheels	L127			100.0	
Body zero line to windshield cowl point	L130a			5.0	
Tire size	L102	Refer to Page 18			

AMA Specifications—Passenger Car

MAKE OF CAR: Chevrolet MODEL YEAR: 1963 DATE ISSUED: 10-1-62 REVISED: (*)

FRONT COMPARTMENT DIMENSIONS

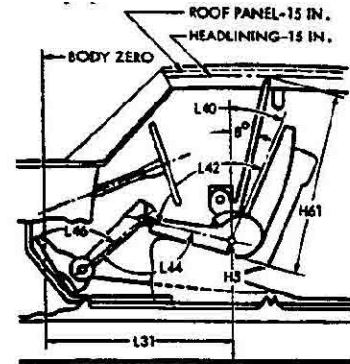
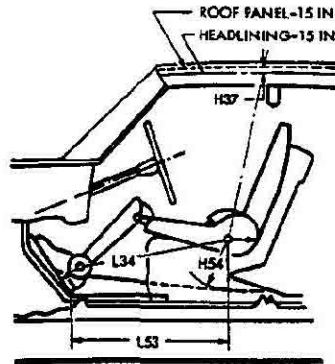
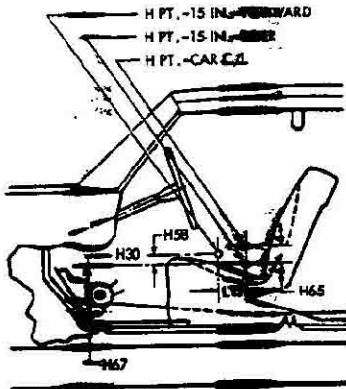

MODEL	Chevrolet		Sedans	Coupe	Convertible	Station Wagon
H Point to body zero line	333a			42.0		
H Point to ground	333a			20.0		
Effective head room	461a	39.0		38.5		39.0
Headlining to roof height	337	.5		---		1.0
Maximum effective leg room - accelerator	334a			41.0		
H Point to heel point	330a			9.0		
Depressed floor covering thickness	357a					
Back angle	340a	26°		25°		26°
Hip angle	342a			104°		
Knee angle	344a			145°		
Foot angle	446a	120°		119°	118°	120°
H Point differential, side to center	355a			.4		
H Point to tunnel	354a			3.0		7.0
H Point to accelerator floor point	353a			33.0		
H Point travel	317a			5.0		
H Point rise	4158a			.7		

AMA Specifications—Passenger Car

MAKE OF CAR Chevrolet MODEL YEAR 1963 DATE ISSUED 10-1-62 REVISED()

GROUND CLEARANCE DIMENSIONS

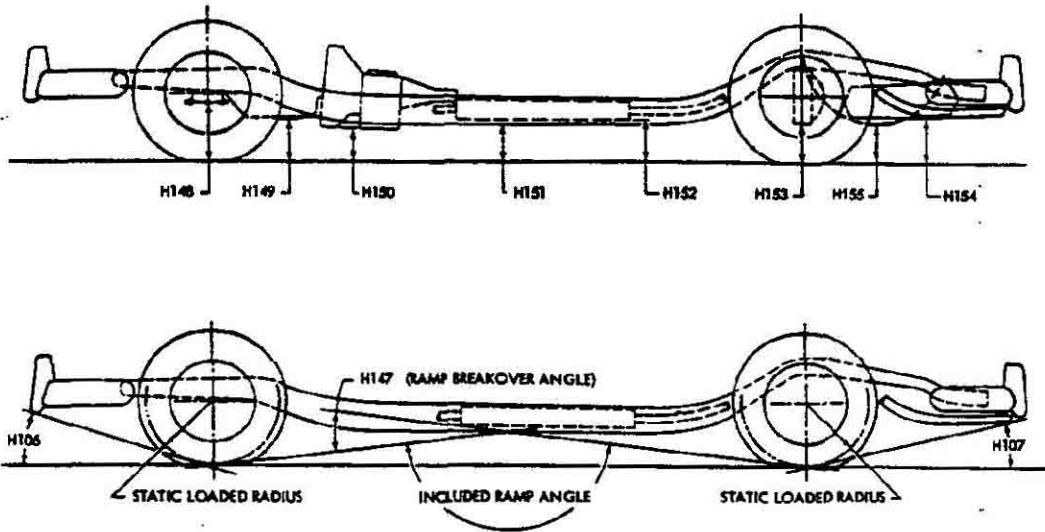

MODEL Chevrolet	Ref. No.	Sedans	Coupe	Convertible	Station Wagon
Angle of approach	H106			31°	
Angle of departure	H107			14°	
Ramp breakover angle	H147			13°	
Front suspension to ground	H148			7.5	
Oil pan to ground	H149			7.0	
Flywheel housing to ground	H150			7.0	
Frame structure to ground	H151			7.0	
Exhaust system to ground	H152			6.0	
Rear axle differential to ground	H153			7.5	
Fuel tank to ground	H154			8.0	
Spare tire well to ground	H155			---	8.5
Minimum running ground clearance	H156			6.0	

AMA Specifications – Passenger Car

MAKE OF CAR Chevrolet MODEL YEAR 1963 DATE ISSUED 10/1/62 REVISED(*)

SEAT AND ENTRANCE DIMENSIONS

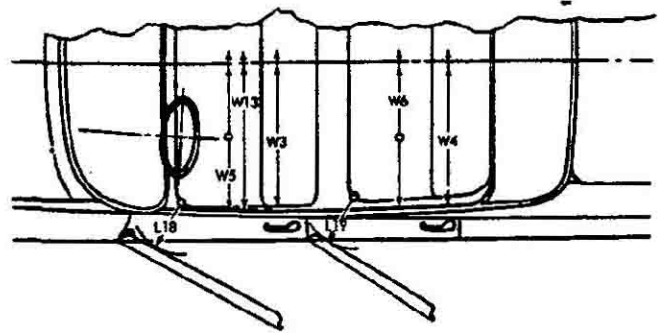
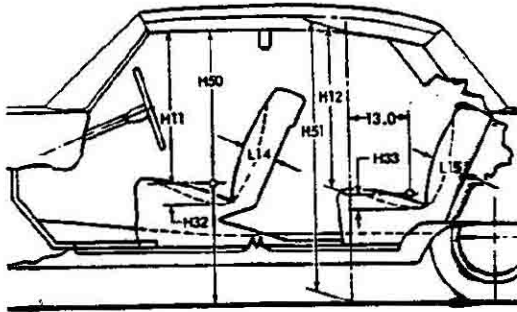

MODEL Chevrolet	Ref. No.	Sedans	Coupe	Convertible	Station Wagon
Shoulder room - front	W3a			59.0	
Hip room - front	W5a			63.5	
Seat width - front	W16a			57.5	
Upper body opening to ground - front	H50a	50.0		48.5	50.0
Entrance height - front	H11a	30.0		29.0	33.0
Entrance foot clearance - front	L18			15.0	
Seat cushion deflection - front	H32a			4.5	
Seat back thickness - front	L14			7.5	
Shoulder room - rear	W4a	57.5	57.0	51.0	58.0
Hip room - rear	W6a	62.5	55.0	52.0	63.5
Upper body opening to ground - rear	H51a	50.0	---	---	50.0
Entrance height - rear	H12a	29.0	---	---	30.5
Entrance foot clearance - rear	L19	11.5		9.0	13.5
Seat cushion deflection - rear	H33a	4.0		4.5	
Seat back thickness - rear	L15	8.5		7.5	5.5

AMA Specifications – Passenger Car

MAKE OF CAR Chevrolet MODEL YEAR 1963 DATE ISSUED 10/1/62 REVISED(*)

REAR COMPARTMENT DIMENSIONS

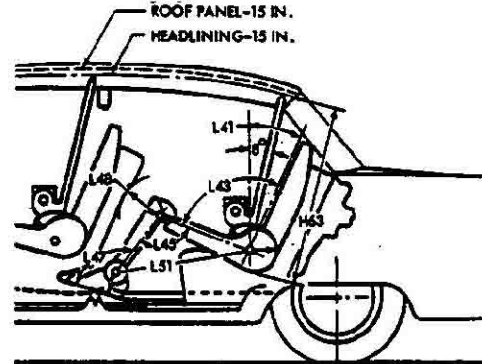
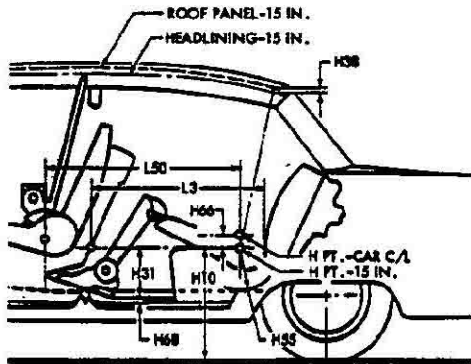

MODEL Chevrolet	Ref. No.	Sedans	Coupe	Convertible	Station Wagon
H Point couple distance	L50a	35.5	33.0		35.5
H Point to ground	H10a	19.5	18.5		19.5
Effective head room	H63a	38.0			40.0
Headlining to roof height	H38	.8	.6	---	.8
Minimum effective leg room	L51a	38.0	35.0		38.0
H Point to heel point	H31a	12.0	11.0		12.0
Depressed floor covering thickness	H68a				
Minimum knee room	L48a	5.0	3.5		5.0
Rear compartment room	L3	28.5	26.0		28.5
Back angle	L41a	23°	18°		23°
Hip angle	L43a	90°	77°		90°
Knee angle	L45a	105°	91°		109°
Foot angle	L47a	117°		112°	117°
H Point differential, side to center	H66a	.6	.7		.6
H Point to tunnel	H55a	6.0	5.3		6.0

AMA Specifications - Passenger Car

MAKE OF CAR Chevrolet MODEL YEAR 1963 DATE ISSUED 10/1/62 REVISED(*)

LUGGAGE COMPARTMENT

MODEL Chevrolet	Ref. No.	Sedans	Coupe	Convertible	Station Wagon
Usable luggage capacity (See instructions)			19.0		----
Liftover height*	H301a		22.0		---- vertical
Position of spare tire storage		Horizontal on trunk forward shelf, left side			behind right rear quarter
Method of holding lid open		Torsion bars, counterbalance			access panel

THIRD SEAT DIMENSIONS

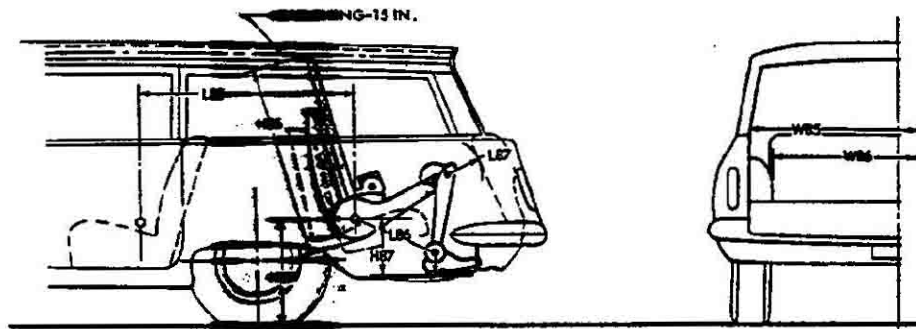

MODEL Chevrolet	Ref. No.	1645 - 1845 9-Passenger
Seat facing direction		Rearward
Shoulder room	W85a	52.0
Hip room	W86a	46.0
H Point couple distance	L85a	39.5
H Point to ground	H85a	22.0
Effective head room	H86a	37.0
Effective leg room	L86a	33.0
H Point to heel point	H87a	12.5
Knee room	L87a	10.0
Back angle	L88a	17°
Hip angle	L89a	81°
Knee angle	L90a	81°
Foot angle	L91a	114°

* Vertical dimension from luggage compartment lower opening to ground.

AMA Specifications – Passenger Car

MAKE OF CAR Chevrolet MODEL YEAR 1963 DATE ISSUED 10/1/62 REVISED(•)

VISION AND CONTROL DIMENSIONS

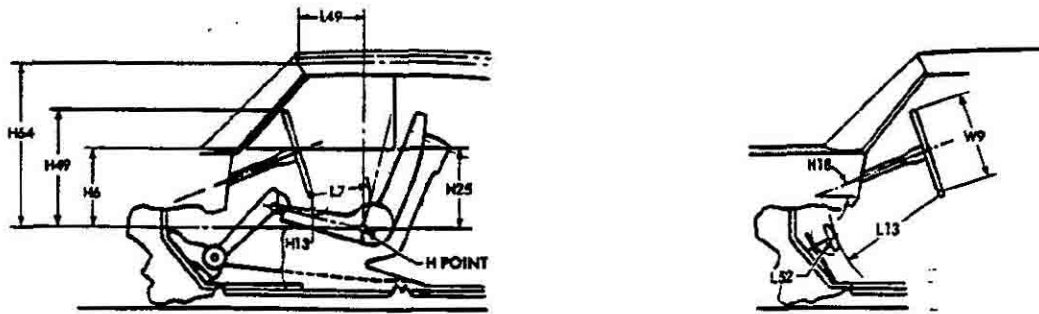

MODEL Chevrolet	Ref. No.	Sedans	Coupe	Convertible	Station Wagon
H Point to windshield bottom DLO	H6a			19.0	
H Point to windshield upper DLO	H64a	33.5	31.5		27.5
H Point to windshield upper DLO	L49a	11.5	14.0		11.5
Belt height - front	H25a			16.5	
Steering wheel center to centerline of car	W7			16.0	
Steering wheel maximum outside diameter	W9			17.0	
Steering column angle - horizontal	H18			16°	
H Point to top of steering wheel	H49a			3.5	
Steering wheel torso clearance	L7a			11.0	
Steering wheel thigh clearance	H13a			5.0	
Brake pedal knee clearance	L13			24.5	
Brake pedal to accelerator	L52a			4.5	
Tumble-home	W122a				

AMA Specifications – Passenger Car

MAKE OF CAR Chevrolet MODEL YEAR 1963 DATE ISSUED 10/1/62 REVISED (e)

MODEL 1200-1600-1800

BODY—MISCELLANEOUS INFORMATION

Drs. hinged (front, rear)	Front doors	Front
	Rear doors	Front
Type of finish (lacquer, enamel, other)		Acrylic lacquer
Hood hinge location (front, rear)		Rear
Hood counterbalanced (yes, no)		Yes
Hood release control (Internal, external)		External
Vehicle (Serial) No. Location		Left front body hinge pillar
Engine No. Location		On pad at front right side of Cylinder deck
Theft protection - type		Shielded ignition lock terminals, key removable in "lock" or "on" position.
Vent window control method (crank, friction pivot)		Crank
		None
Seat cushion type		Polyurethane foam with zigzag springs
		Cotton-jute with zigzag springs (a)
Seat back type		Cotton-zigzag springs
		Cotton-zigzag springs
Windshield type (single curved, compound curved, other)		One-piece, compound curve
Rear window type (flat, curved, one piece, three piece)		One-piece, curved
Side glass type (curved, flat)		Flat
Side glass exposed surface area		1322.8
Windshield glass exposed surface area		1589.7
Backlight glass exposed surface area		1257.1
Total glass exposed surface area		4169.6 (a)

(a) - Biscayne 4-door sedan

AMA Specifications—Passenger Car

MAKE OF CAR Chevrolet MODEL YEAR 1963 DATE ISSUED 10/1/62 REVISED ^(*)

STATION WAGON—CARGO SPACE DIMENSIONS

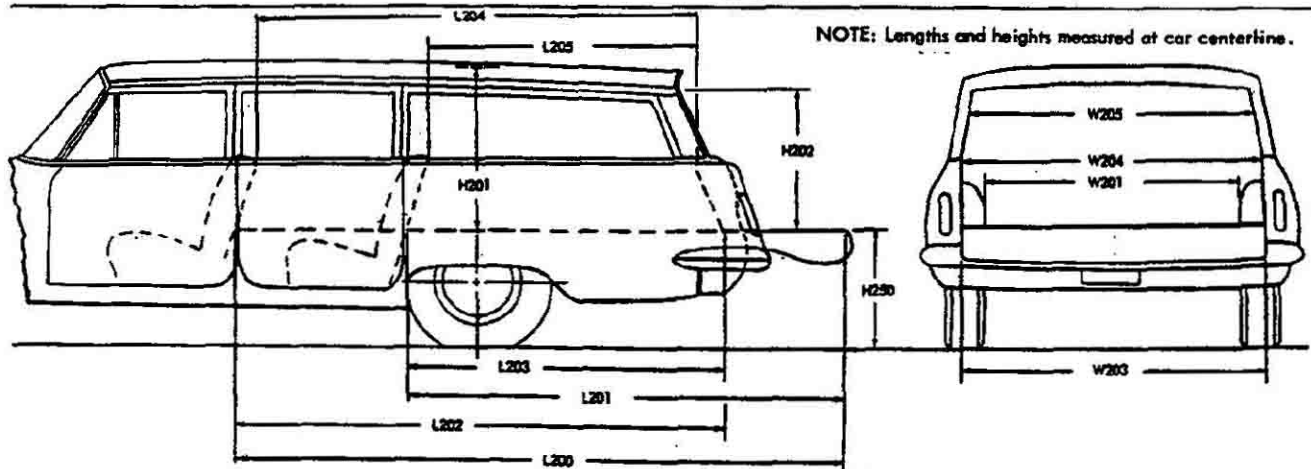

MODEL	Chevrolet	Ref. No.	1235 - 1635 - 1645 - 1835 - 1845
Floor length from back of front seat at floor level to end of lowered tail gate or floor		L200	118.5
Floor length from back of second seat at floor level to end of lowered tail gate or floor		L201	84.5
Floor length from back of front seat at floor level to inside of closed tail gate		L202	94.0
Floor length from back of second seat at floor level to inside of closed tail gate		L203	60.0
Minimum horizontal distance from top rear of front seat back to inside of tail gate at belt		L204	82.5
Minimum horizontal distance from top rear of second seat back to inside of tail gate at belt		L205	47.0
Maximum width of cargo space at floor - specify location		W200a	62.0 forward of wheelhouse
Minimum distance between wheel houses at floor level		W201	46.0
Rear end opening width at floor		W203	56.5
Rear end opening width at belt		W204	54.5
Maximum width of rear opening above belt		W205	54.0
Maximum height - floor covering to headlining at centerline of rear axle		H201	31.5
Maximum height of rear opening - tail and lift gates open		H202	30.5
Platform height from ground to top of tail gate floor covering at rear most edge of tail gate - curb weight		H250	23.0
Rear end closure (e.g., one piece door, hinged left - sliding glass, drop tail gate)			Hinged tailgate with folding link supports and manual retractable rear window (a)
Cargo volume index (cu. ft.) W4 x L204 x H201 1728			87.0 (b)

(a) Electrically operated window on 9-Passenger (opt. on 6-Pass. Wagon)

(b) Plus 10.5 cu. ft. for hidden compartment in 6-Pass; plus 5.7 cu. ft. in 9-Pass. Form Rev. 3-62

DIMENSION DEFINITIONS

- W3a** SHOULDER ROOM - FRONT. The minimum lateral dimension between the door garnish moldings or nearest interference. Measured at H Point station.
- W4a** SHOULDER ROOM - REAR. Measured in the same manner as W3a.
- W5a** HIP ROOM - FRONT. The lateral dimension through H Point to trimmed surfaces.
- W6a** HIP ROOM - REAR. Measured in the same manner as W5a.
- W7** STEERING WHEEL CENTER TO CENTERLINE OF CAR. Measured horizontally from steering wheel center to centerline of car. The point at steering wheel center is located in the surface plane of wheel.
- W9** STEERING WHEEL MAXIMUM OUTSIDE DIAMETER. Define if other than round.
- W16a** SEAT WIDTH - FRONT. The maximum trimmed width of front seat cushion.
- W85a** SHOULDER ROOM - THIRD SEAT. Measured in the same manner as W3a.
- W86a** HIP ROOM - THIRD SEAT. Measured in the same manner as W5a.
- W101** TREAD - FRONT. Measured at centerline of tires, with nominal camber, at ground.
- W102** TREAD - REAR. Measured at centerline of tires at ground.
- W103** MAXIMUM OVERALL CAR WIDTH. Include bumpers, moldings, or sheet metal protrusions.
- W106** FRONT FENDER OVERALL WIDTH. Measured at centerline of front wheels, excluding moldings.
- W107** REAR FENDER OVERALL WIDTH. Measured at centerline of rear wheels, excluding moldings.
- W116** MAXIMUM OVERALL BODY WIDTH. Measured across body, excluding hardware and applied moldings, but including fenders when integral with body.
- W117** MAXIMUM BODY WIDTH AT #2 PILLAR. Measured across body at #2 pillar, excluding hardware and applied moldings.
- W120a** MAXIMUM OVERALL CAR WIDTH, FRONT DOORS OPEN. Measured with front doors in maximum hold-open position.
- W121a** MAXIMUM OVERALL CAR WIDTH, REAR DOORS OPEN. Measured in same manner as W120a.
- W122a** TUMBLE-HOME. The angle from vertical to the front door glass outer surface or the chord of a curved door glass, measured at the front H Point station.
- L3** REAR COMPARTMENT ROOM. The horizontal dimension from the back of front seat to front of rear seat back at a height tangent to the top of rear seat cushion.
- L7a** STEERING WHEEL TORSO CLEARANCE. The minimum distance from the back edge of steering wheel, in straight-ahead position, to the Torso Line.
- L13** BRAKE PEDAL KNEE CLEARANCE. The minimum dimension from the lower edge of the steering wheel to the brake pedal face centerline.
- L14** SEAT BACK THICKNESS - FRONT. The maximum thickness of the seat back, excluding bolsters.
- L15** SEAT BACK THICKNESS - REAR. Measured in the same manner as L14.
- L17a** H POINT TRAVEL. The horizontal dimension between the H Point in the most forward and rearward seat positions.
- L18** ENTRANCE FOOT CLEARANCE - FRONT. The minimum horizontal dimension between seat and normal line of door or pillar at a height between the sill plate bead and 4.0 inches above the bead. Door should be in the maximum hold-open position.
- L19** ENTRANCE FOOT CLEARANCE - REAR. Measured in the same manner as L18 on four-door models. On two-door styles, the minimum dimension between rear corner of front seat, with front seat back tilted forward, and trimmed lock pillar, built-in quarter armrest panel, or rear seat cushion at a height between the sill plate bead and 4.0 inches above the bead.
- L30** BODY ZERO LINE TO ACTUAL FRONT OF DASH. If actual Front of Dash is to the rear of Body Zero Line, it is identified by a minus (-) sign.
- L31a** H POINT TO BODY ZERO LINE - FRONT. Horizontal dimension.
- L34a** MAXIMUM EFFECTIVE LEG ROOM - ACCELERATOR. Measured along a diagonal line from ankle pivot center to H Point plus a constant of 10.0 inches. Measured with the right foot on accelerator pedal.
- L40a** BACK ANGLE - FRONT. The angle between a vertical line through the H Point and the Torso Line.
- L41a** BACK ANGLE - REAR. Measured in the same manner as L40a.
- L42a** HIP ANGLE - FRONT. The angle between Torso Line and a line extending from knee pivot center to H Point.
- L43a** HIP ANGLE - REAR. Measured in the same manner as L42a.
- L44a** KNEE ANGLE - FRONT. The angle between a line from H Point to knee pivot center and a line from the knee pivot center to the ankle pivot center.
- L45a** KNEE ANGLE - REAR. Measured in the same manner as L44a.
- L46a** FOOT ANGLE - FRONT. The angle between a line extended from the knee pivot center through the ankle pivot center and a line tangent to the sole and heel of manikin bare foot.
- L47a** FOOT ANGLE - REAR. Measured in the same manner as L46a.
- L48a** MINIMUM KNEE ROOM - REAR. The minimum dimension from the knee pivot center to the back of front seat back.
- L49a** H POINT TO WINDSHIELD UPPER DLO. The horizontal dimension from H Point to the point of tangency of horizontal line of vision (described in dimension H64a) with body upper structure.

DIMENSION DEFINITIONS (cont.)

- H51a UPPER BODY OPENING TO GROUND - REAR. The vertical dimension from a point on the trimmed body opening to the ground. Measured 13.0 inches forward of the H Point.
- H54a H POINT TO TUNNEL - FRONT. The minimum dimension from the H Point, at car centerline, to top of tunnel.
- H55a H POINT TO TUNNEL - REAR. Measured in the same manner as H54a.
- H58a H POINT RISE. The vertical dimension between the H Point in the most forward and rearward seat positions.
- H61a EFFECTIVE HEAD ROOM - FRONT. The dimension from H Point to the headlining, plus a constant of 4.0 inches. Measured along a line 8" to rear of vertical.
- H63a EFFECTIVE HEAD ROOM - REAR. Measured in the same manner as H61a.
- H64a H POINT TO WINDSHIELD UPPER DLO. Vertical dimension from H Point to highest horizontal line of vision through windshield at 15 inch section.
- H65a H POINT DIFFERENTIAL, SIDE TO CENTER - FRONT. The vertical dimension from side occupant H Point to center occupant H Point.
- H66a H POINT DIFFERENTIAL, SIDE TO CENTER - REAR. Measured in the same manner as H65a.
- H67a DEPRESSED FLOOR COVERING THICKNESS - FRONT. The vertical dimension from manikin accelerator heel point normally to underbody sheet metal immediately below heel point.
- H68a DEPRESSED FLOOR COVERING THICKNESS - REAR. Measured same as H67a.
- H85a H POINT TO GROUND - THIRD SEAT. Vertical dimension.
- H86a EFFECTIVE HEAD ROOM - THIRD SEAT. Measured in the same manner as H61a.
- H87a H POINT TO HEEL POINT - THIRD SEAT. Measured in the same manner as H31a.
- H101 OVERALL HEIGHT. Measured with full design load.
- H102 FRONT BUMPER TO GROUND. Minimum dimension.
- H104 REAR BUMPER TO GROUND. Minimum dimension.
- H106 ANGLE OF APPROACH. Minimum angle between ground and a line tangent to arc of front tire static loaded radius and touching the limiting point of interference on front bumper, bumper guard, or gravel deflector.
- H107 ANGLE OF DEPARTURE. Minimum angle between ground and a line tangent to arc of rear tire static loaded radius and touching the limiting point of interference on rear bumper, bumper guard, gravel deflector, tail pipe, fender or other interfering structure.
- H111 ROCKER PANEL TO GROUND - REAR. The vertical dimension from ground to bottom of rocker panel, excluding flanges. Measured at front of rear wheel opening.
- H112a ROCKER PANEL TO GROUND - FRONT. The vertical dimension from ground to bottom of rocker panel, excluding flanges. Measured at foremost point of rocker panel.
- H114 HOOD AT REAR TO GROUND. Measured from hood opening line on shroud, exclusive of moldings.
- H115 STEP HEIGHT - FRONT (DESIGN LOAD). The vertical dimension from top of sill plate bead, at C/L of front door sill plate, to ground.
- H116 STEP HEIGHT - REAR (DESIGN LOAD). Measured in same manner as dimension H115.
- H122 WINDSHIELD SLOPE ANGLE. The angle between a vertical line and the windshield surface at car centerline. On compound-curved windshields the chord of the arc is used and limited to that section of the windshield comprehended by an 18-inch chord.
- H130 STEP HEIGHT - FRONT (CURB LOAD). The vertical dimension from top of sill plate, at C/L of front door sill plate, to ground.
- H131 STEP HEIGHT - REAR (CURB LOAD). Measured in same manner as H130.
- H132 BOTTOM OF DOOR TO GROUND, OPEN - FRONT. Measured from bottom outside corner of door with door in maximum hold-open position.
- H133 BOTTOM OF DOOR TO GROUND, CLOSED - FRONT. Same point on door as H132 dimension, with door closed.
- H134 BOTTOM OF DOOR TO GROUND, OPEN - REAR. Measured in same manner as H132.
- H135 BOTTOM OF DOOR TO GROUND, CLOSED - REAR. Measured in same manner as H133.
- H136a BODY ZERO TO GROUND - FRONT. A vertical dimension measured at front wheel centerline.
- H137a BODY ZERO TO GROUND - REAR. A vertical dimension measured at rear wheel centerline.
- H147 RAMP BREAKOVER ANGLE. Supplement of included ramp angle (180° minus included ramp angle) over which car can pass without interference; measured with car sitting on a level surface, using lines tangent to arcs of front and rear static loaded radii and intersecting at point on underside of car which defines the smallest angle.
- H148 FRONT SUSPENSION TO GROUND. Minimum clearance measured from lower control arm inner shaft or lowest point on the car centerline.
- H149 OIL PAN TO GROUND. Minimum clearance measured from sheet metal or drain plug.
- H150 FLYWHEEL/CONVERTER HOUSING AND TRANSMISSION ASSEMBLY TO GROUND. Minimum clearance.
- H151 FRAME STRUCTURE TO GROUND. Minimum clearance measured approximately midway between front and rear axles. In this measurement, cross bars and X-members shall be considered part of frame.
- H152 EXHAUST SYSTEM TO GROUND. Minimum clearance. Specify location.
- H153 REAR AXLE DIFFERENTIAL SYSTEM TO GROUND. Minimum clearance.
- H154 FUEL TANK TO GROUND. Minimum clearance measured from sheet metal or drain plug, but excluding supports or straps.
- H155 SPARE TIRE WELL TO GROUND. Minimum clearance.
- H156 MINIMUM RUNNING GROUND CLEARANCE. Location of measurement on the car is to be clearly recorded.

DIMENSION DEFINITIONS (cont.)

L50a H POINT COUPLE DISTANCE. The horizontal dimension from the front seat H Point to the rear seat H Point.

L51a MINIMUM EFFECTIVE LEG ROOM - REAR. Measured along a diagonal line from ankle pivot center to H Point plus a constant of 10.0 inches. Measured with the foot positioned to nearest interference between seat structure and toe, instep or lower leg.

L52a BRAKE PEDAL TO ACCELERATOR. The minimum dimension from center of brake pedal face to accelerator. Measured in the side view.

L53a H POINT TO ACCELERATOR FLOOR POINT. The horizontal dimension from intersection of accelerator and depressed floor covering to the H Point.

L85a H POINT COUPLE DISTANCE - THIRD SEAT. The horizontal dimension from the second seat H Point to the third seat H Point.

L86a EFFECTIVE LEG ROOM - THIRD SEAT. Measured in the same manner as L51a. With rear-facing third seat, foot is positioned in foot well or to nearest interference with rear end or rear closure.

L87a KNEE ROOM - THIRD SEAT. Measured in the same manner as L48a. With rear-facing third seat, dimension is measured to rear closure.

L88a BACK ANGLE - THIRD SEAT. Measured in the same manner as L40a.

L89a HIP ANGLE - THIRD SEAT. Measured in the same manner as L42a.

L90a KNEE ANGLE - THIRD SEAT. Measured in the same manner as L44a.

L91a FOOT ANGLE - THIRD SEAT. Measured in the same manner as L46a.

L101 WHEELBASE.

L102 TIRE SIZE.

L103 OVERALL LENGTH. Include bumper guards if standard equipment.

L104 OVERHANG - FRONT. Measured from C/L of front wheels to front of car, including bumper guards if standard equipment.

L105 OVERHANG - REAR. Measured from C/L of rear wheels to rear of car, including bumper guards if standard equipment.

L123 BODY UPPER STRUCTURE LENGTH AT CAR CENTERLINE. The horizontal dimension from the theoretical intersection of extended windshield glass plane and normal cowl surface to the theoretical intersection of extended back window glass plane and normal deck surface; or in the case of a Fastback roof or Station Wagon, to back glass lower reveal molding, or rubber when molding is not used.

L127 BODY ZERO LINE TO CENTERLINE OF REAR WHEELS. A horizontal dimension.

L128a HOOD LENGTH AT CAR CENTERLINE. The horizontal dimension from the foremost point on sheet metal hood surface, excluding series identification or ornamentation, to the theoretical intersection of extended windshield glass plane and normal cowl surface.

L129a DECK LENGTH AT CAR CENTERLINE. The horizontal dimension from the rearmost point of the body sheet metal (visible above bumper), excluding series identification or ornamentation, to the theoretical intersection of extended back window glass plane and normal deck surface.

L130a BODY ZERO LINE TO WINDSHIELD COWL POINT. The horizontal dimension from body zero line to the theoretical intersection of extended windshield glass plane and normal cowl surface.

H5a H POINT TO GROUND - FRONT. Vertical dimension.

H6a H POINT TO WINDSHIELD BOTTOM DLO. Vertical dimension.

H10a H POINT TO GROUND - REAR. Vertical dimension.

H11a ENTRANCE HEIGHT - FRONT. The vertical dimension from H Point to upper trimmed body opening.

H12a ENTRANCE HEIGHT - REAR. The vertical dimension from H Point to the upper trimmed body opening at a section 13.0 inches forward of the H Point.

H13a STEERING WHEEL THIGH CLEARANCE. The minimum dimension from the bottom of steering wheel, in straight-ahead position, to centerline of thigh.

H18 STEERING COLUMN ANGLE - HORIZONTAL. The angle the centerline of steering column makes with the horizontal.

H25a BELT HEIGHT - FRONT. The vertical dimension from H Point to bottom of side window DLO.

H30a H POINT TO HEEL POINT - FRONT. The vertical dimension from the H Point to the manikin accelerator heel point on the depressed floor covering.

H31a H POINT TO HEEL POINT - REAR. The vertical dimension from the H Point to the manikin heel point on the depressed floor covering.

H32a SEAT CUSHION DEFLECTION - FRONT. The vertical dimension from a point on the undepressed seat cushion to the depressed seat cushion. Measured at the H Point station.

H33a SEAT CUSHION DEFLECTION - REAR. Measured in the same manner as H32a.

H37 HEADLINING TO ROOF HEIGHT - FRONT. The dimension from the intersection of the headlining and the extended effective head room line to the roof panel. Measured perpendicularly to the roof panel.

H38 HEADLINING TO ROOF HEIGHT - REAR. Measured in the same manner as H37.

H49a H POINT TO TOP OF STEERING WHEEL. The vertical dimension from the H Point to top of steering wheel, in straight-ahead position.

H50a UPPER BODY OPENING TO GROUND - FRONT. The vertical dimension from a point on the trimmed body opening to the ground. Measured at the H Point station.

AMA Specifications – Passenger Car

INDEX

SUBJECT	PAGE NO.	SUBJECT	PAGE NO.
Angles of Approach, Departure	25	Lamp Bulbs	13
Automatic Transmission	1, 16	Lamp Height & Spacing	14
Axis, Steering	21	Legroom	26, 27, 30
Axle, Rear	1, 17	Lengths - Overall	1, 23
Battery	10	Lifters, Valve	5
Bearings, Engine	4, 5, 6	Linings - Clutch, Brake	15, 19
Belts - Fan, Generator, Water Pump	9	Lubrication	6, 7, 15, 16, 17
Body - General Information, types	Title, 1, 22, 32	Motor, Starting	10
Exterior Dimensions	1, 22, 23, 24	Muffler	7
Interior Dimensions	26, 27, 28, 29, 30	Overdrive	16
Clearance Dimensions	25	Piston Pins & Rings	2, 4
Brakes - Parking, Service, Power	18, 19	Pistons	2
Camber	21	Power Brakes	18
Camshaft	5	Power Steering	20
Capacities		Power Teams	3
Cooling System	9	Propeller Shaft, Universal Joints	16, 17
Fuel Tank	8	Pumps - Oil, Fuel	7, 8
Lubricants		Water	9
Engine Crankcase	7	Radiator, Hoses	9
Transmission and Overdrive	15, 16	Ramp Break-over Angle	25
Rear Axle	17	Ratios - Axle	1, 3, 17
Carburetor	3, 8	Compression	1, 2, 3
Caster	21	Steering	20
Choke, Automatic	8	Transmission	15, 16
Circuit Breakers, Fuses	14	Rear Axle	1, 3, 17
Clearance, Ground	25	Regulator - Generator	10
Clutch - Pedal Operated	15	Rims	18
Coil, Ignition	11	Rings, Piston	4
Connecting Rods	4	Rods - Connecting	4
Cooling System	9	Shock Absorbers, Front & Rear	19
Crankcase Ventilation	7	Spark Plugs	11
Crankshaft	5	Speedometer	12
Cylinders and Cylinder Head	2	Springs - Front & Rear Suspension	20, 21
Dimension Definitions	34, 35, 36	Valve, Engine	6
Distributor - Ignition	11	Stabilizer (Sway Bar) - Front & Rear	20, 21
Electrical System	10, 11, 12, 13, 14	Starting Motor	10
Engine		Steering	20, 21
Bore, Stroke, Displacement, Type	1, 2	Suppression - Ignition, Radio	11
Compression Ratio	1, 2	Suspension - Front & Rear	19, 20, 21
Firing Order, Cylinder Numbering	2, 11	Switches	12
General Information, H.P. & Torque	1, 2	Tailpipe	7
Lubrication	6, 7	Thermostat, Cooling	9
Power Teams	3	Timing, Engine & Valve	5, 6, 11
Exhaust System	7	Tires	1, 18
Fan, Cooling	9	Toe in	21
Filters - Engine Oil, Fuel System	7, 8	Torque Converter	16
Frame	19	Torque - Engine, Rated	1, 2, 3
Front Suspension	19, 20	Transmission - Types	1, 3, 8, 15, 16
Fuel, Fuel Pump, Fuel System	1, 2, 8	Automatic	1, 3, 8, 15, 16
Fuel Injection	1, 8	Manual & Overdrive	1, 3, 8, 15, 16
Fuses, Circuit Breakers	14	Ratios	15, 16
Generator and Regulator	10	Tread	1, 22
Glass	24, 32	Turning Diameter	20
Height (Lamps)	14	Unitized Construction	19
Headroom - Body	26, 27, 30	Universal Joints, Propeller Shaft	16, 17
Heights - Overall	1, 24	Valves - Intake & Exhaust	5, 6
Hood	23	Vibration Damper	5
Horns	12	Voltage Regulator	10
Horsepower - Brake, Taxable	1, 2, 3	Water Pump	9
Ignition System	11	Weights - Shipping, Curb	33
Inflation - Tires	18	Wheel Alignment	21
Instruments	7, 12	Wheelbase	1, 23
Kingpin (Steering Axis)	21	Wheels & Tires	18
		Wheel Spindle	21
		Widths - Car & Body	1, 22
		Windshield	24, 32
		Windshield Wiper	12