



OLDSMOBILE

**SHOP
MANUAL**

**TRI-POWER
CARBURETION
SUPPLEMENT**

SERVICE DEPARTMENT

OLDSMOBILE DIVISION

CARBURETION

CONTENTS

Subject	Page	Subject	Page
INTRODUCTION	2	AIR HORN DISASSEMBLY	8
THEORY OF OPERATION	2	CARBURETOR BODY DISASSEMBLY	10
FLOAT SYSTEM	2	THROTTLE FLANGE DISASSEMBLY	11
IDLE SYSTEM	2	CLEANING AND INSPECTION	11
PART THROTTLE SYSTEM	3	CLEANING OF PARTS	11
POWER SYSTEM	3	INSPECTION OF PARTS	11
PUMP SYSTEM	4	ASSEMBLY AND ADJUSTMENT	11
CHOKE SYSTEM	4	THROTTLE FLANGE ASSEMBLY	11
REMOVAL AND REPLACEMENT	5	CARBURETOR BODY ASSEMBLY	11
REMOVAL FROM CAR	6	CHOKE ASSEMBLY	12
INSTALLATION ON CAR	6	AIR HORN ASSEMBLY	13
ADJUSTMENTS ON CAR	7	FLOAT LEVEL ADJUSTMENT	13
SECONDARY LOCKOUT	7	FLOAT DROP ADJUSTMENT	14
FRONT TO REAR THROTTLE ROD	7	COMPLETION OF ASSEMBLY	14
CHECK UNLOADER	7	ADJUSTMENTS (ON OR OFF CAR)	15
SLOW IDLE	8	PUMP ROD ADJUSTMENT	15
FAST IDLE	8	VACUUM SWITCH ADJUSTMENT	15
THROTTLE RETURN CHECK	8	CHOKE ROD ADJUSTMENT	16
CARBURETOR DISASSEMBLY	8	UNLOADER ADJUSTMENT	16
CHOKE DISASSEMBLY	8	TRANSMISSION LINKAGE ADJUSTMENT	16

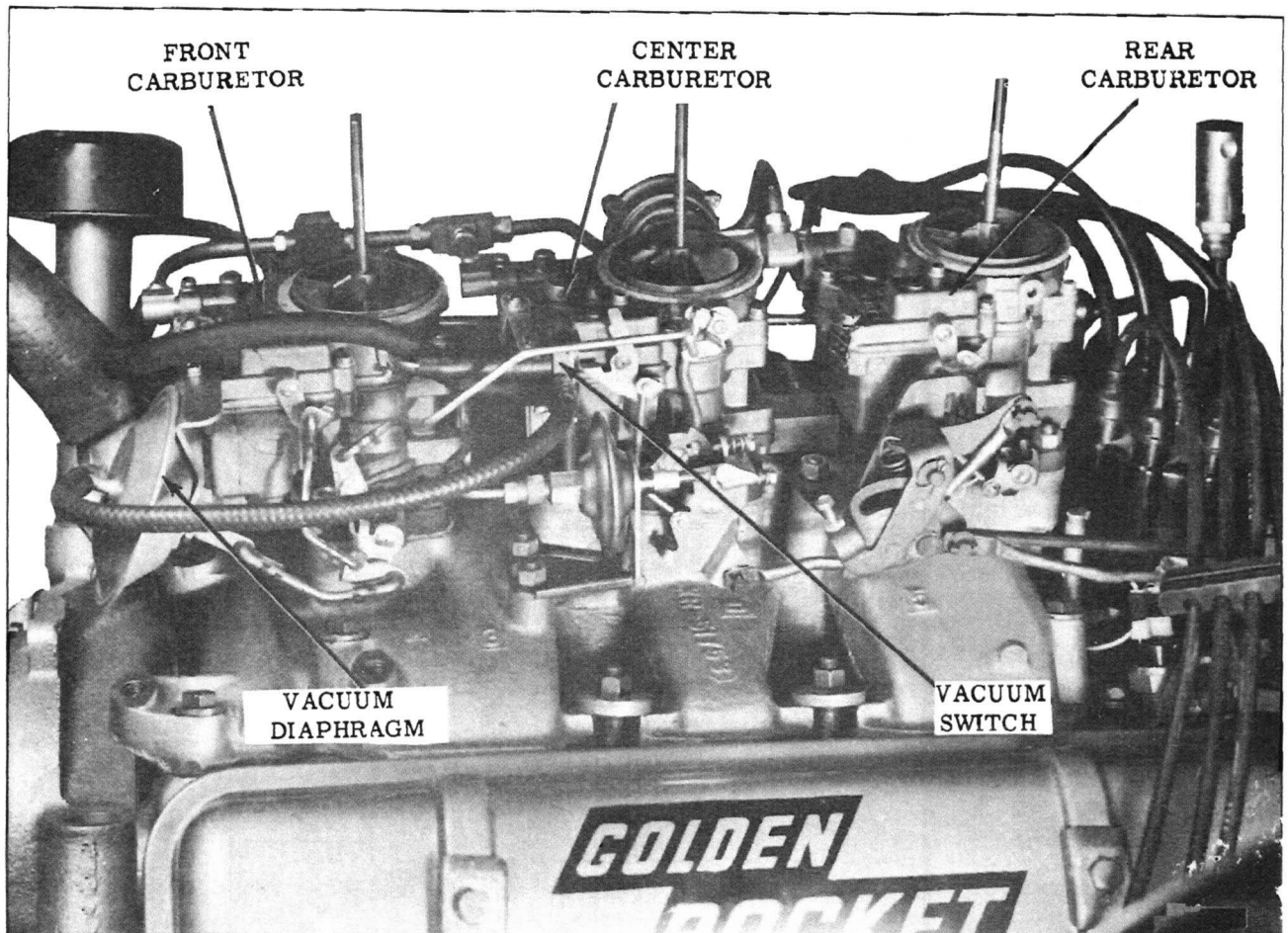

Fig. 1 Three 2-Barrel Carburetor Installation

INTRODUCTION

The Rochester Model 2GC Carburetor used on Oldsmobile for 1957 has a triple two-barrel compound installation. The center carburetor contains all systems of carburetion, including Float, Idle, Part Throttle, Power, Pump, and Choke. The front and rear carburetors contain only Float, Pump, and Main Metering Systems. The throttle valves and accelerator pump on the front carburetor are operated by a vacuum diaphragm which is controlled by a vacuum switch mounted on the center carburetor. The vacuum is supplied to the switch by the booster side of the fuel pump. The throttle shafts on the front and rear carburetors, controlled by the vacuum diaphragm, are connected by a common rod, so they will both operate simultaneously.

During idle and part throttle ranges the center carburetor feeds fuel while the front and rear carburetors remain out of operation. The front and rear carburetors operate in the following manner: A vacuum switch located on the center carburetor is operated by a tang on the accelerator pump lever. The vacuum switch is connected directly to the vacuum booster pump on the engine. The switch also has a vacuum line which runs to a vacuum diaphragm mounted on the front carburetor. This vacuum diaphragm is connected by linkage to the throttle lever on the front carburetor.

On normal acceleration the center carburetor only, feeds air and fuel until the throttle valves are opened approximately 60 degrees. When the throttle valves open approximately 60 degrees on the center carburetor, the vacuum switch is automatically opened, applying vacuum to the diaphragm mounted on the front carburetor. Vacuum applied to this diaphragm opens the throttle valves on both front and rear carburetors simultaneously, feeding fuel from the pump and main metering systems.

On deceleration the vacuum switch closes, shutting off all vacuum applied to the diaphragm. Air is then bled from inside the carburetor air horn by another line through the vacuum switch to the vacuum diaphragm unit, allowing the diaphragm to return to its normal position under spring tension, thereby closing the throttle valves on the front and rear carburetors. The front and rear carburetors feed fuel and air any time the throttle valves in the center carburetor are opened 60 degrees or more.

THEORY OF OPERATION

FLOAT SYSTEM

All Three Carburetors (Fig.2)

The float system controls the level of fuel in the carburetor bowl. Entering fuel first travels through the inlet strainer (1) to remove particles which might block jets or passages. Then the fuel passes thru the needle and seat (2) into the carburetor bowl; flow continues until the rising liquid level raises the float (3) to a position where the needle valve (2) is closed. Thus, the fuel can be

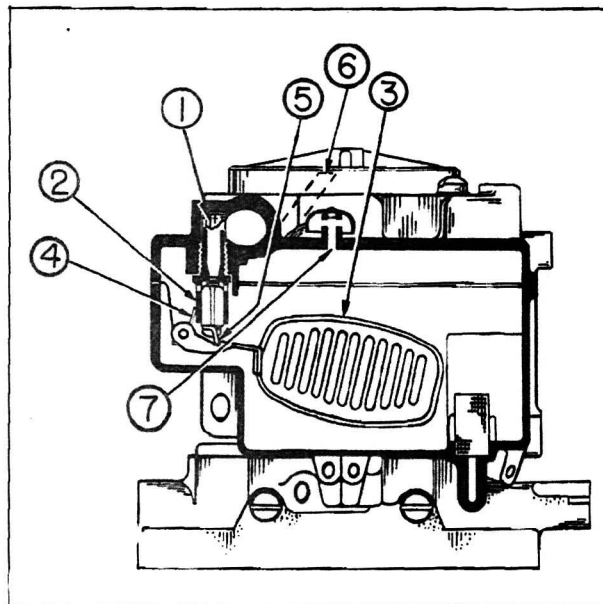

Fig. 2 Float System (All Three Carburetors)

regulated by setting the float to close the valve when the proper level is reached.

The float tang (4) prevents the float from traveling too far downward. A float needle pull clip (5) connecting the float arm to the needle valve keeps the needle from sticking closed in the seat.

The float bowl is internally (6) and externally (7) vented in the center carburetor. The front and rear carburetors are internally vented (6) to eliminate any possible change in fuel/air mixture due to air cleaner restriction. The center carburetor is externally vented to the atmosphere for idle operation.

IDLE SYSTEM

Center Carburetor Only (Fig.3)

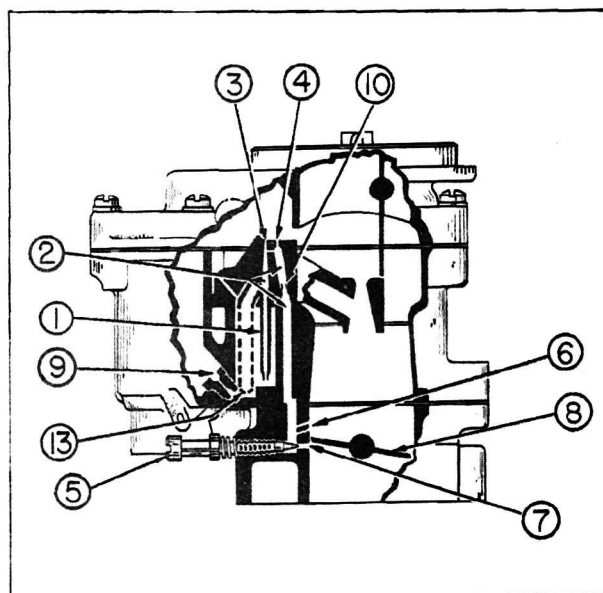

Fig. 3 Idle System (Center Carburetor)

The idle system consists of the idle tubes (1), idle passages (2), idle air bleeds (3 and 4), idle adjustment needles (5), idle discharge holes (6), and the idle needle adjusting hole (7).

In the low idle speed position, the throttle valve (8) is slightly open, allowing a small amount of air to pass between the wall of the carburetor bore and the edge of the throttle valve.

The idle needle hole (7) is in the high vacuum area below the throttle valve, but the fuel is vented to atmospheric pressure.

The fuel is drawn from the bowl through the main metering jets (9) into the main well (13). It is metered by the idle fuel metering orifice at the lower tip of the idle tube (1) and travels up the idle tube. When the fuel reaches the top of the idle tube, it mixes with air drawn through the first idle air bleed (3) and the mixture moves through the horizontal idle passage.

Air enters the second idle air bleed (4) and combines with the mixture which then passes through the restriction (10) and down the vertical idle passage to the idle discharge holes (6) located just above the throttle valve where more air is added to the mixture. The mixture then passes through the idle needle hole (7) and into the bore of the carburetor.

In addition to this mixture of fuel and air, there is air entering the bore of the carburetor through the slightly opened throttle valves (8). For smooth operation, the air from the bore and the air/fuel mixture from the idle needle hole must combine to form the correct final mixture for low idle engine speed.

The position of the idle adjusting needle (5) governs the amount of air/fuel mixture admitted to the carburetor bore. Except for this variable at the idle adjustment needle, the idle system is specifically calibrated for idle and low engine speeds.

As the throttle valve is opened, a pressure differential change occurs: opening of the valve progressively exposes the idle discharge holes (6) to manifold vacuum and the air stream, with the result that they deliver additional air/fuel mixture for off-idle engine requirements.

PART THROTTLE All Three Carburetors (Fig. 4)

This system is used on all three carburetors; however, the front and rear carburetors do not come into operation until approximately 60 degree throttle opening of the center carburetor.

Further opening of the throttle valve increases the speed of the air stream passing through the venturi system (1), thus lowering the pressure (raising the vacuum) in the small venturi area (2) of the carburetor bore. At the same time, the edge of the throttle valve is moved away from the wall of the bore, progressively reducing the vacuum

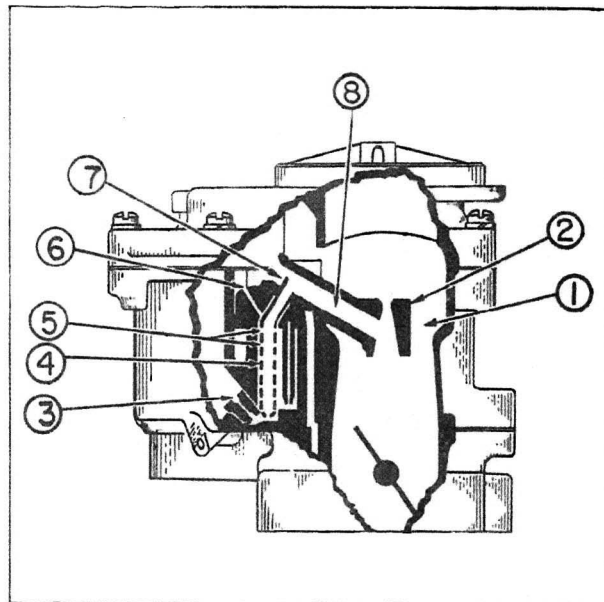

Fig. 4 Part Throttle System (All Three Carburetors)

and thus reducing the mixture at the idle discharge holes.

Since the low pressure point is now in the small venturi area (2), fuel and air/fuel mixture will be drawn from the fuel bowl through the main metering system to the venturi as follows:

The fuel passes through the main metering jets (3) into the main well where it rises in the main well tube (4). Air entering through the main well air bleeds (6) in the cluster is mixed with fuel through the vents in the main well tube. The mixture continues up the main well tube through the nozzle (7) where more air is added. The mixture flows through the high speed passage (8) to the small venturi (2) where it mixes with additional air and moves on to the bore of the carburetor, through the intake manifold, and into the cylinders as a final mixture for part throttle operation.

POWER SYSTEM Center Carburetor Only (Fig. 5)

The power system provides additional fuel for heavy load and high speed engine requirements.

A spring loaded power piston (1) controlled by vacuum regulates the power valve (2) to supply additional fuel according to speed and load.

The power piston vacuum channel (3) is open to manifold vacuum beneath the throttle valves; thus, the vacuum in the channel rises and falls with engine manifold vacuum.

During idle and part throttle operation, the vacuum in the channel (3) is normally high enough to hold the power piston (1) in the fully raised position against the tension of the power valve spring (4). As the manifold vacuum drops with engine load and speed, the calibrated spring (4) forces the piston down against the power valve (2). The power valve is opened by this method and it allows

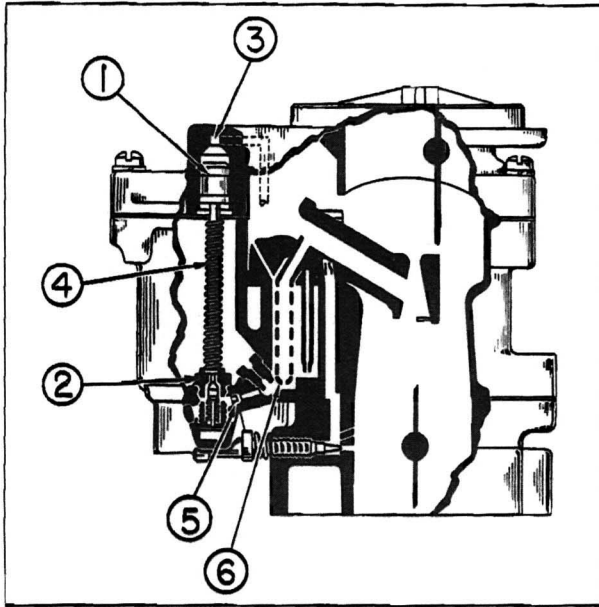

Fig. 5 Power System (Center Carburetor)

additional fuel to flow through the calibrated power restrictions (5) into the main wells (6).

The power valve (2) allows a gradual increase in fuel flow as the power valve is fully opened to permit a maximum calibrated fuel flow from the power system.

As the load decreases, manifold vacuum increases. The increasing vacuum pull on the piston (1) gradually overcomes the spring tension of the power valve spring and the power piston returns to its original raised position; then the valve (2) is fully closed.

PUMP SYSTEM

All Three Carburetors (Fig. 6)

Extra fuel for smooth, quick acceleration is

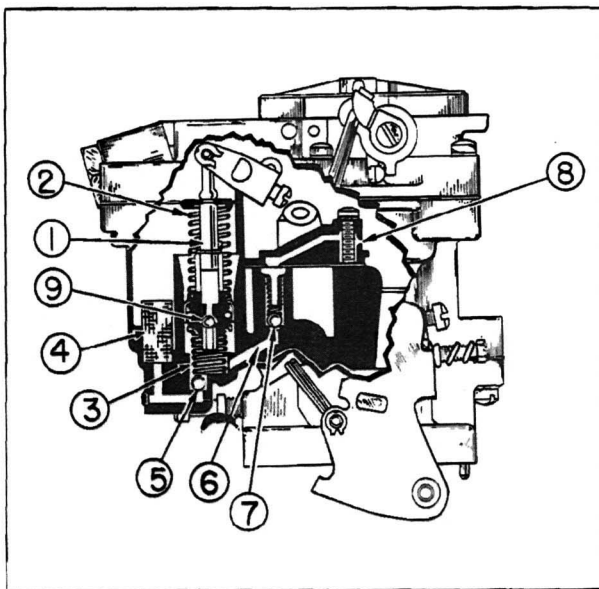

Fig. 6 Pump System (All Three Carburetors)

supplied by a double-spring pump plunger (1). The combination of the top (2) and bottom (3) springs is calibrated to move the plunger in such a manner that a smooth, sustained charge of fuel is delivered for acceleration.

The fuel passes from the bowl through the pump screen (4) to remove any dirt, then is drawn past the ball check (5) into the pump well on the intake stroke of the plunger. When the plunger is pushed down for acceleration, the force of the stroke seals the ball check (5) to prevent flow to the fuel bowl and the fuel is forced up the pump discharge passage.

The pressure of the fuel lifts the pump outlet ball check (7) from its seat and the fuel passes on through the pump jets (8) in the cluster where it is sprayed into the venturi and delivered to the engine.

The pump plunger head embodies a ball check (9) and seat, designed to eliminate fuel percolation problems in the pump system. When the engine is idling or not operating, excessive fuel vapor in the pump well will rise through the plunger head and bypass the ball (9) then circulate into the fuel bowl, which is vented to the atmosphere.

Without this feature, vapor pressure in the pump system might force fuel through the pump passage and into the engine, causing hard starting when hot because of excess fuel in the manifold or poor initial acceleration due to lack of the proper amount of fuel in the pump system.

CHOKE SYSTEM

Center Carburetor Only (Fig. 7)

For cold engine operation, a rich mixture at the carburetor is required so that a combustible mixture remains in the manifold system to be drawn into the cylinders after considerable condensation of the fuel vapor on the cold engine parts. The

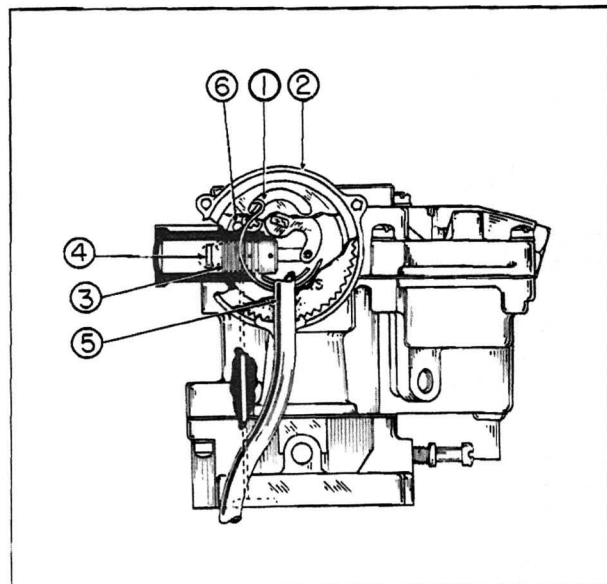

Fig. 7 Choke System (Center Carburetor)

function of the choke system is to subject all fuel outlets in the bore of the carburetor to high vacuum, while restricting the intake of air, thus drawing into the engine the required rich mixture.

The choke system includes a thermostatic coil (1), housing (2), and choke piston (3), all of which are interconnected with the choke valve and linkage.

The choke is controlled by a combination of intake manifold vacuum, air velocity against the offset choke valve, atmospheric temperature, and induced heat from the exhaust manifold system.

When the engine is cold, the bi-metal thermostatic coil (1) expands and closes the choke valve. As soon as the engine is started, two forces within the carburetor start the de-choking operation. Engine manifold vacuum exerts a pulling action on the choke piston (3) through the vacuum passage (4). Hot fresh air passes through the choke stove and carburetor heat tube (5) and begins to warm the thermostatic coil (1). The choke valve is offset; therefore, the speed and volume of the air stream through the air horn of the carburetor will proportionately affect the movement of the choke valve. Engine manifold vacuum continues to pull hot air through the heat tube (5) and over the baffle plate, through the restriction (6) at a speed and volume calibrated to effect maximum efficiency from the entire system.

This operation continues until the thermostatic coil is completely relaxed; at this point, the choke

valve is vertical in the carburetor air horn and has no effect on the operation of the unit.

The operation of the choke system will recycle when the engine is stopped and allowed to become cold and the same sequence of events will take place when it is started again and goes through the warm-up period.

The fast idle cam and linkage maintains sufficient throttle opening for cold starting and keeps the engine running at a sufficient speed to prevent stalling during the warm-up period.

The mechanical unloader eliminates the possibility of the choke closing during heavy loads and acceleration by cracking the choke valve at wide open throttle.

The front and rear carburetors are locked out when the choke is on, by means of a lockout lever on the front carburetor and a rod which connects this lever to the choke trip lever. When the choke is even partially on, the lockout lever will not permit the throttle valves of the front and rear carburetors to open.

REMOVAL AND REPLACEMENT OF CARBURETORS

NOTE: The front and rear carburetors can be removed and replaced individually, but, because of clearances, the rear one must be removed any time the center one is to be removed.

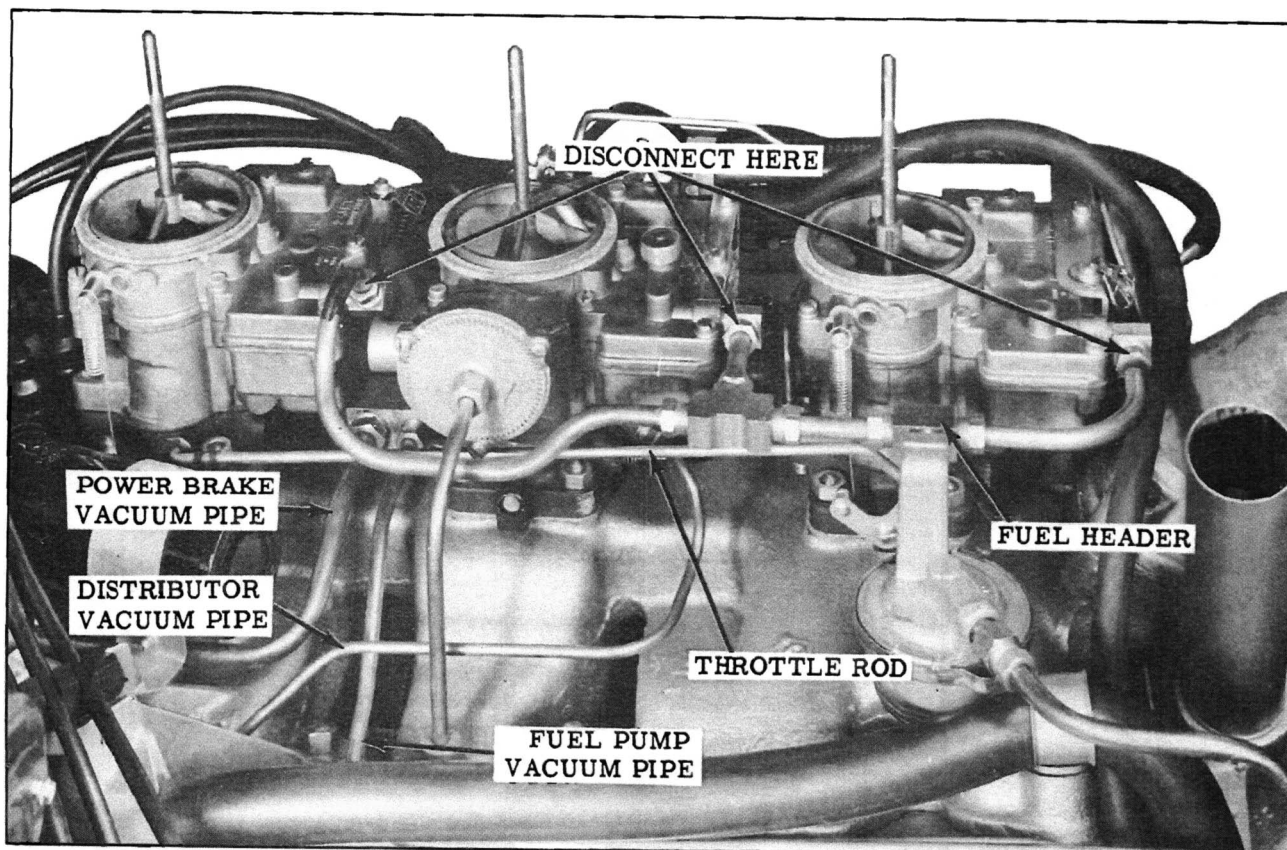

Fig. 8 Right Side View of Installation

REMOVAL FROM CAR

1. Remove air cleaner.
2. Disconnect fuel lines from carburetors in three places as shown in Fig. 8.
3. Disconnect the rod between the front and rear carburetors and remove.
4. Disconnect the distributor vacuum line from the throttle body of the center carburetor.
5. Remove lower clip from auxiliary bellcrank rod and disconnect rod from throttle lever on center carburetor. (See Fig. 9)
6. Remove vacuum hoses from vacuum switch, vacuum diaphragm, and front carburetor.
7. Disconnect secondary lockout rod and remove.
8. Disconnect throttle return check pipe from throttle return check and remove throttle return check from manifold.
9. Remove rear carburetor.
10. Disconnect vacuum pipe at rear of center carburetor. (Power brake pipe also if so equipped)
11. Remove the center carburetor.
12. Remove the front carburetor.
13. Remove throttle return check pipe from throttle body of front carburetor.

14. Remove choke heat tube from center carburetor.

INSTALLATION ON CAR

1. Install throttle return check pipe on front carburetor and install carburetor to manifold.
2. Install choke heat tube loosely to center carburetor and install carburetor to manifold, and then tighten heat tube.
3. Connect vacuum pipe, (and power brake pipe if used) to fitting in rear of throttle body on the center carburetor.
4. Install rear carburetor.
5. Install throttle return check to manifold and connect vacuum pipe.
6. Install secondary lockout rod. For adjustment of this rod see ADJUSTMENTS ON THE CAR.
7. Install the three vacuum hoses as shown in Fig. 10.

NOTE: Be sure that hose from fuel pump to switch is in the clip at front of carburetor.

8. Install auxiliary bellcrank rod onto the lever on center carburetor and install clip.
9. Connect the distributor vacuum line to the throttle body in the center carburetor.
10. Install the throttle rod connecting the front

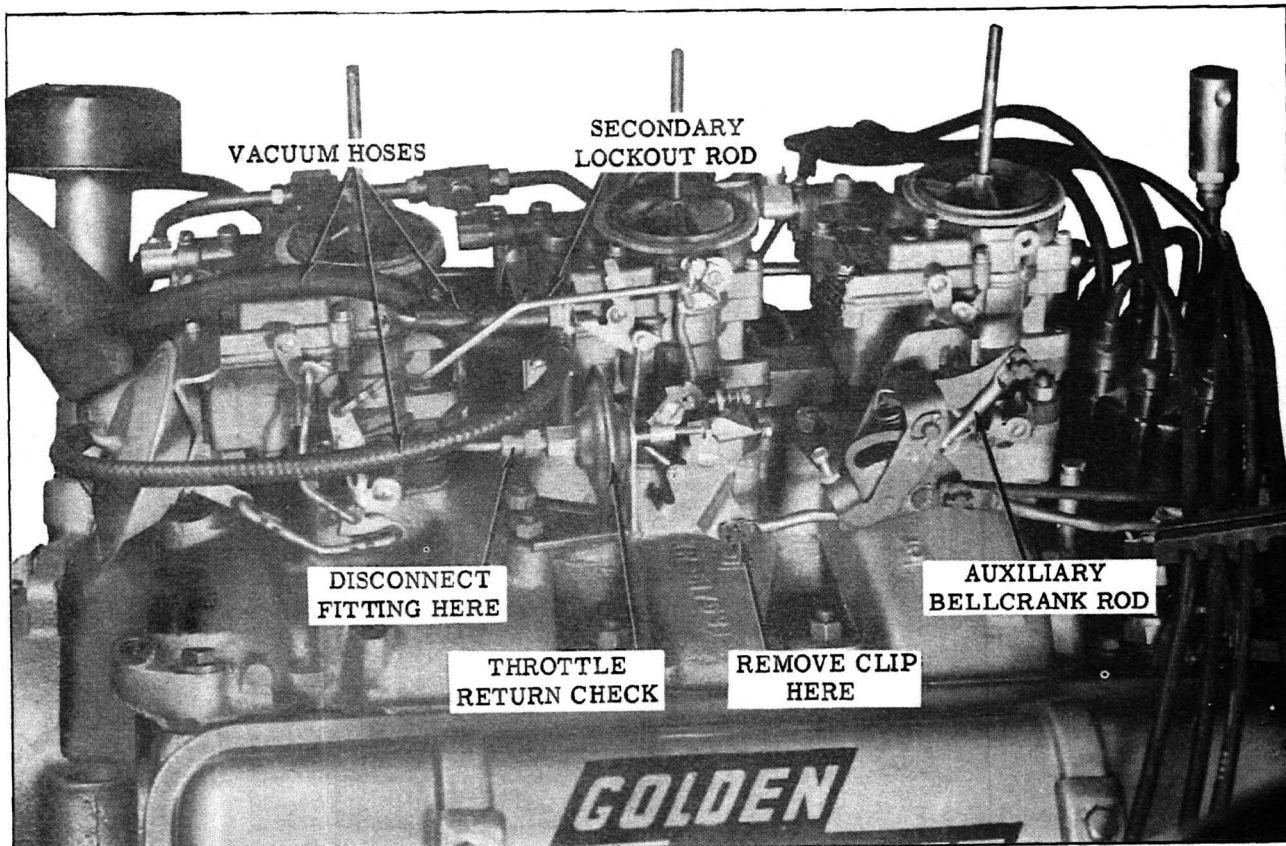

Fig. 9 Left Side View of Installation

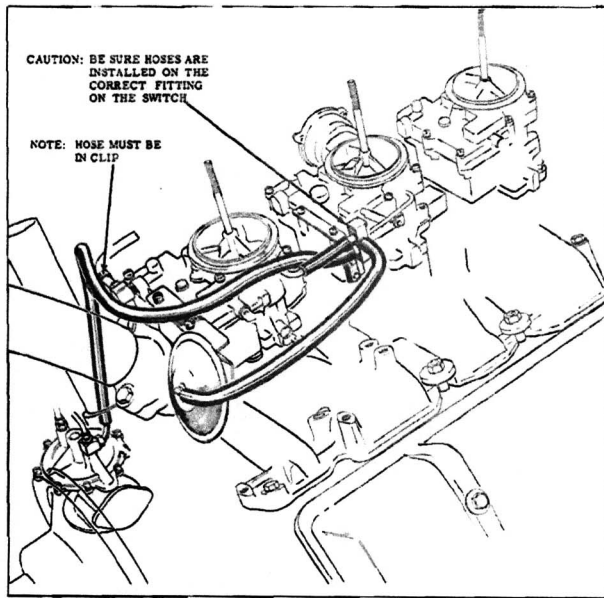

Fig. 10 Vacuum Hoses

and rear carburetors into the throttle lever on the front carburetor only. For adjustment of this rod and completion of assembly see ADJUSTMENTS ON THE CAR.

11. Connect the fuel lines to the three carburetors.

ADJUSTMENTS ON THE CAR

There are five adjustments that must be made and one that must be checked with the carburetors mounted on the engine.

SECONDARY LOCKOUT ADJUSTMENT

1. Hold choke valve completely open. Check distance from side of lockout lever to the side of the tang on throttle shaft with a feeler gauge as shown in Fig. 11. This distance should be .030".
2. Using Tool BT-18 or similar bending tool, bend rod to obtain this adjustment.

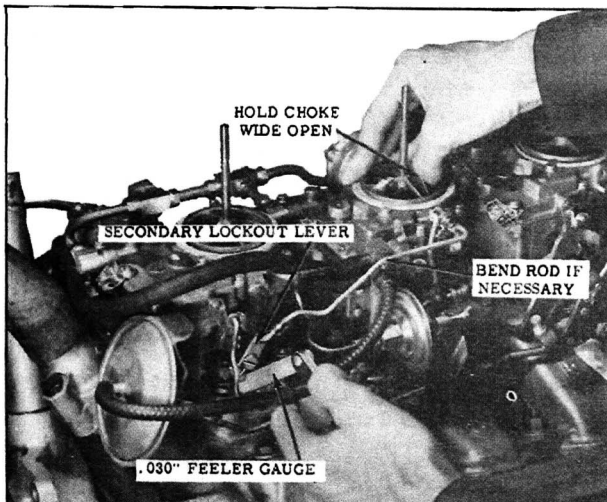

Fig. 11 Secondary Lockout Adjustment

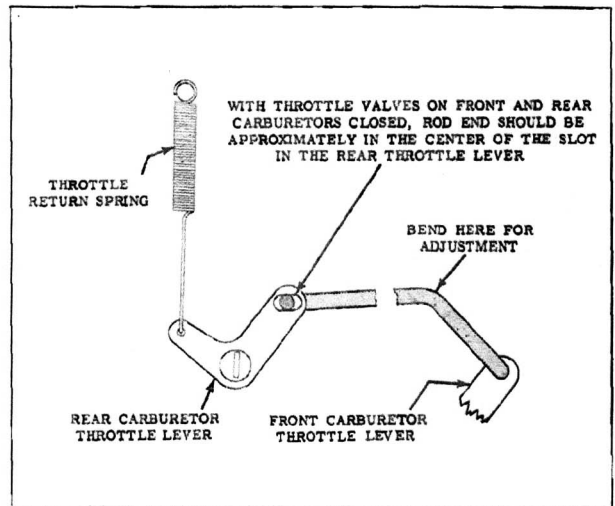

Fig. 12 Front to Rear Carburetor Throttle Rod Adjustment

FRONT TO REAR THROTTLE ROD ADJUSTMENT

1. Be sure throttle valves on front and rear carburetors are completely closed.
2. With front of rod attached to throttle lever on front carburetor, rear of rod must be in middle of slotted hole in the throttle lever on the rear carburetor. (See Fig. 12)
3. Using Tool BT-18 or similar bending tool, bend rod to obtain this adjustment.

CHECK UNLOADER ADJUSTMENT

1. Depress accelerator to the bottom of its travel.

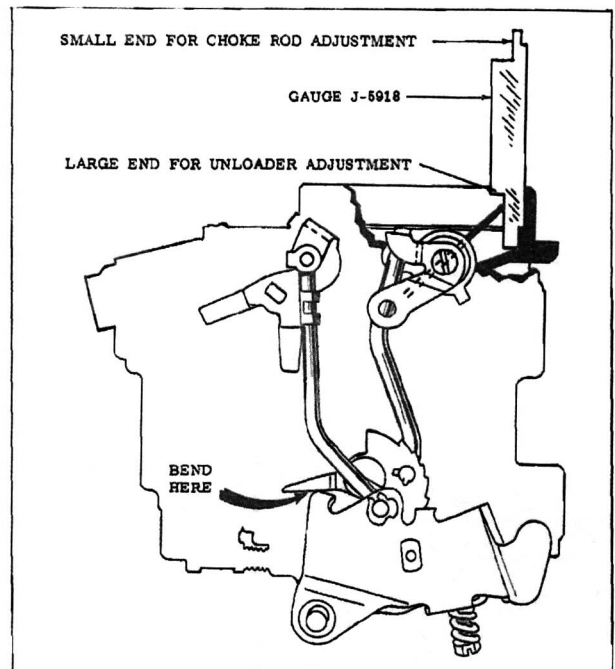

Fig. 13 Unloader Adjustment

(Be sure that choke trip lever is in contact with choke counterweight.)

- Using large end of Tool J-5918, check clearance between top of choke valve and inner wall of air horn. (See Fig. 13)
- Using BT-69 or similar tool, bend tang of throttle shaft to obtain correct adjustment.

SLOW IDLE ADJUSTMENT

Engine must be at operating temperature with air cleaner removed and throttle return check holding Tool J-6342 in place.

On cars equipped with air conditioning, compressor clutch must be engaged.

H.M.T. in "D" - 425 R.P.M.

S.M.T. in "Neutral" - 450 R.P.M.

After the idle R.P.M. is stabilized, turn in or out each idle adjusting needle screw using Tool BT-1000 until the smoothest possible idle is obtained. (See Fig. 14) This normally is accompanied by a higher manifold vacuum reading and/or an increase of idle R.P.M.

FAST IDLE ADJUSTMENT

When the engine is cold and the choke valve is partially closed, it is necessary that the engine R.P.M. at idle be higher than normal to prevent stalling. This adjustment, if correct, will assure proper engine R.P.M. during the warm-up period.

- Rotate the fast idle cam so that the fast idle screw is resting on the high step of the cam.
- With the engine running at operating temperature and transmission selector lever in neutral, adjust the fast idle screw to obtain an engine speed of 1500-1600 R.P.M.

THROTTLE RETURN CHECK ADJUSTMENT

The throttle return check is designed to open the throttle valves to increase engine speed when engine vacuum drops if the engine loads up and starts to stall. It also prevents stalling when the

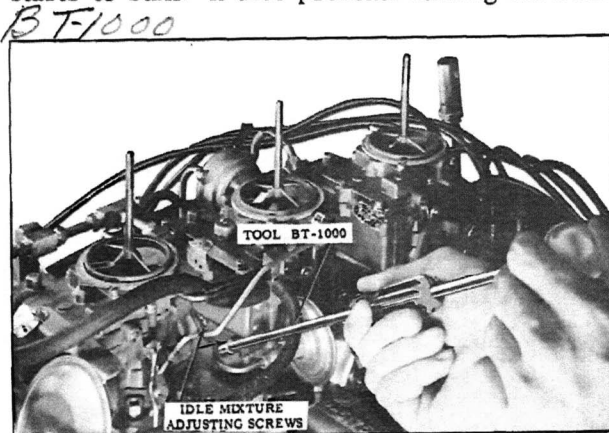

Fig. 14 Adjusting Slow Idle Mixture Screws

driver suddenly takes his foot off the accelerator pedal.

- Be sure the fast idle adjustment has been made; then shut off the engine.
- Rotate the fast idle cam so that the fast idle screw rests on top of the highest step of the fast idle cam.
- Measure the clearance between the contact screw and the contact on the throttle lever. The clearance should be .050".
- If adjustment is necessary, adjust the contact screw using two wrenches.

NOTE: Any time the fast idle is changed, it will be necessary to readjust the throttle return check.

- Install air cleaner.

CARBURETOR DISASSEMBLY

CHOKE DISASSEMBLY (Center Carburetor Only)

- Remove the three choke cover attaching screws and retainers, then remove choke cover, gasket, and coil assembly from carburetor.
- Remove baffle plate from choke housing.
- Remove fast idle cam retaining screw. (See Fig. 15)
- Remove retaining screw at end of choke shaft and carefully remove choke trip lever and counterweight, choke rod, and fast idle cam. Fast idle cam and choke counterweight can be removed from choke rod by turning until slots pass over tang on the rod.

AIR HORN DISASSEMBLY

- (Center Carburetor Only) Remove vacuum

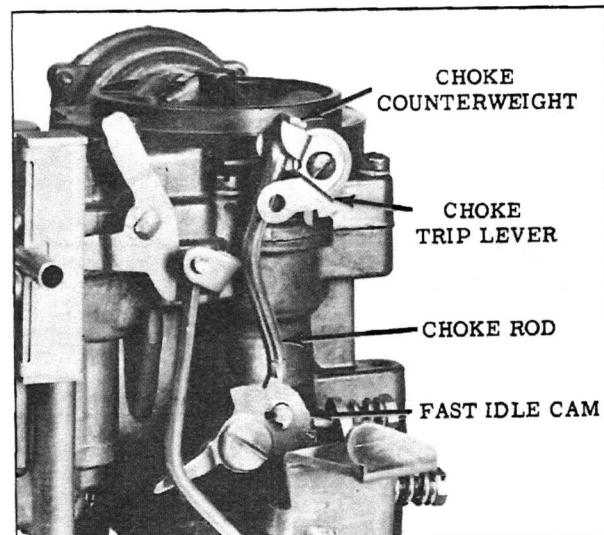

Fig. 15 Fast Idle Cam and Linkage

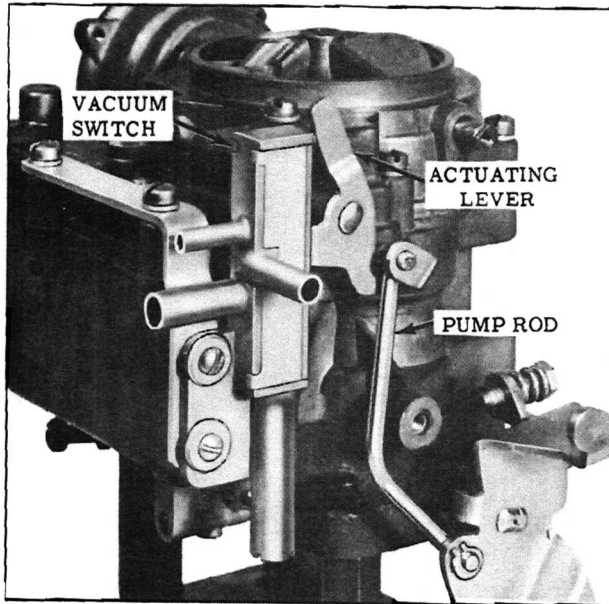

Fig. 16 Vacuum Switch (Center Carburetor)

switch by removing two retaining screws on air horn. (See Fig. 16)

2. Remove pump rod by disconnecting from throttle lever and pump lever.
3. (Front Carburetor Only). Disconnect vacuum diaphragm link from throttle lever. Remove vacuum diaphragm by removing two air horn screws. (See Fig. 17)
4. (Front and Rear Only) Remove throttle return springs. (See Fig. 18)
5. Remove remaining cover screws and lift air horn from body.

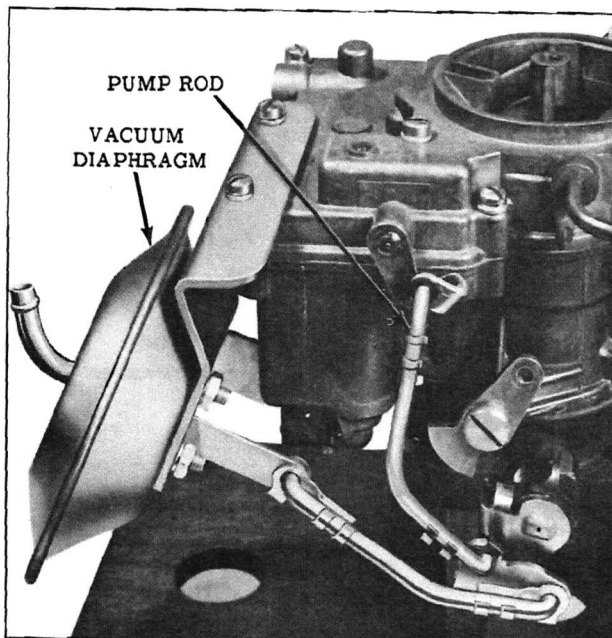

Fig. 17 Vacuum Diaphragm (Front Carburetor)

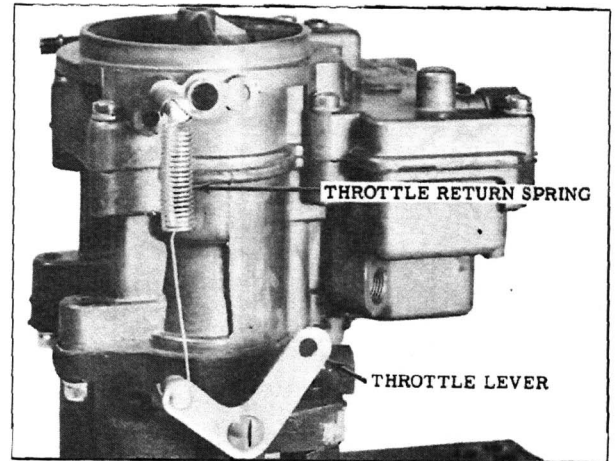

Fig. 18 Throttle Return Springs
(Front and Rear Carburetors)

6. Invert air horn on flat surface. Remove float hinge pin and lift float assembly from cover. Float needle may now be removed from float. (See Fig. 19)
7. Remove float needle seat, gasket and strainer.

IMPORTANT: To avoid damaging needle seat use a needle seat removing tool or specially ground screw driver.
8. (Center Carburetor Only). Carefully remove power piston by depressing shaft and allowing spring to snap back until retainer washer works free of casting.

CAUTION: If power piston shaft is bent or otherwise damaged it will be necessary to replace the piston assembly.
9. Remove retainer from pump plunger shaft and remove plunger assembly from pump arm.
10. The pump lever and shaft may now be removed by loosening set screw on inner arm and removing outer lever and shaft. (See Fig. 20)
11. Remove the Cover gasket.

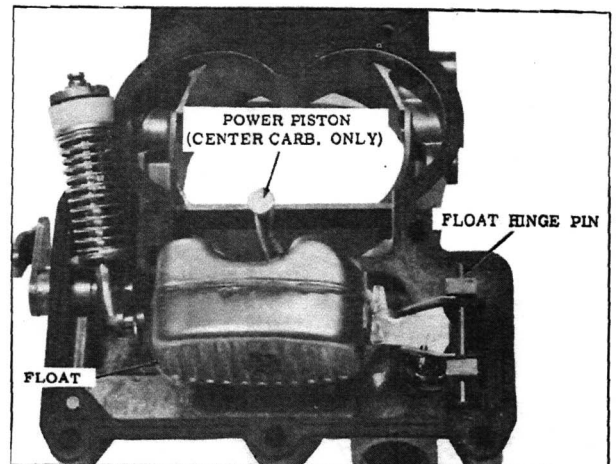

Fig. 19 Air Horn Assembly

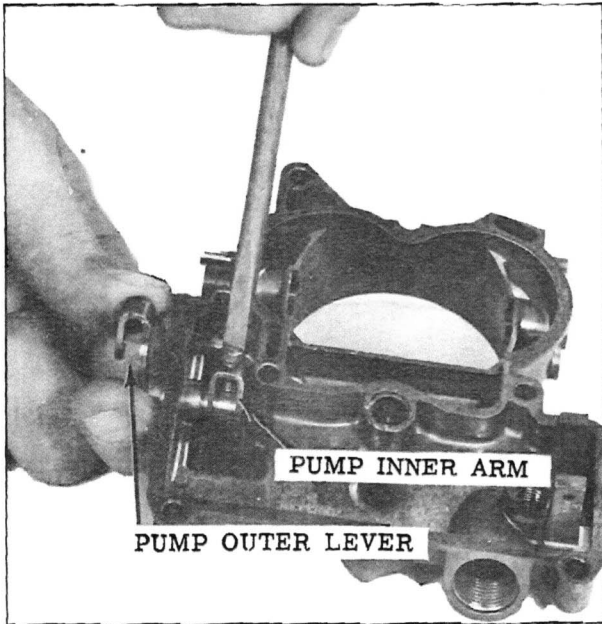

Fig. 20 Pump Inner Arm

12. (Center Carburetor Only). File off staked ends of choke valve screws and remove screws and choke valve.
13. (Center Carburetor Only). Rotate choke shaft counter-clockwise to free choke piston from housing, then pull piston and choke shaft from air horn. (See Fig. 21)
14. (Center Carburetor Only). Remove choke piston from shaft by lightly tapping assembly, with piston pin hole downward, until pin falls out.
15. (Center Carburetor Only). Remove two choke housing attaching screws. Choke housing and gasket may now be removed from air horn assembly.

CARBURETOR BODY DISASSEMBLY

1. Remove pump inlet strainer screen and pump

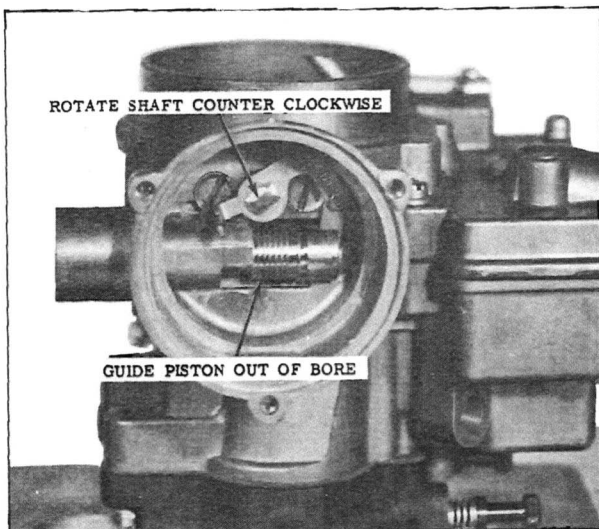

Fig. 21 Choke Piston Removal (Center Carburetor)

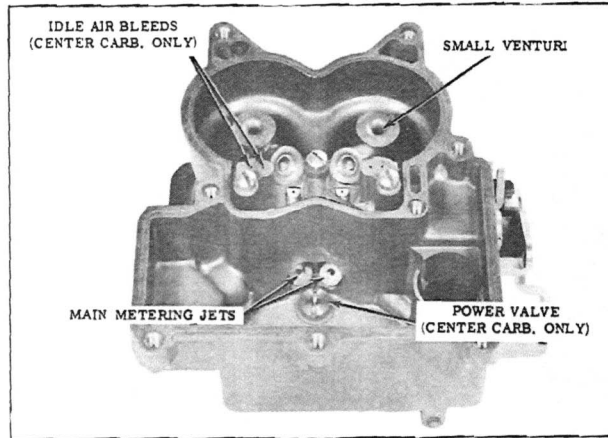

Fig. 22 Cluster, Jets and Power Valve

plunger return spring, then remove aluminum ball check from bottom of pump well.

2. Remove main metering jets. (See Fig. 22)

NOTE: Jets in center carburetor are different from jets in end carburetors and must be kept separate.

3. (Center Carburetor Only). Remove power valve and gasket. (See Fig. 22)
4. Remove three screws on top of cluster, after which cluster and gasket may be removed.
5. Using a pair of needle nosed pliers remove the pump discharge spring retainer, (See Fig. 23) then remove the spring and ball.
6. (Front Carburetor Only). Remove lockout lever by removing attaching screw. (See Fig. 24)
7. Invert carburetor and remove the three bowl-to-throttle body attaching screws. Throttle flange and gasket may now be removed.

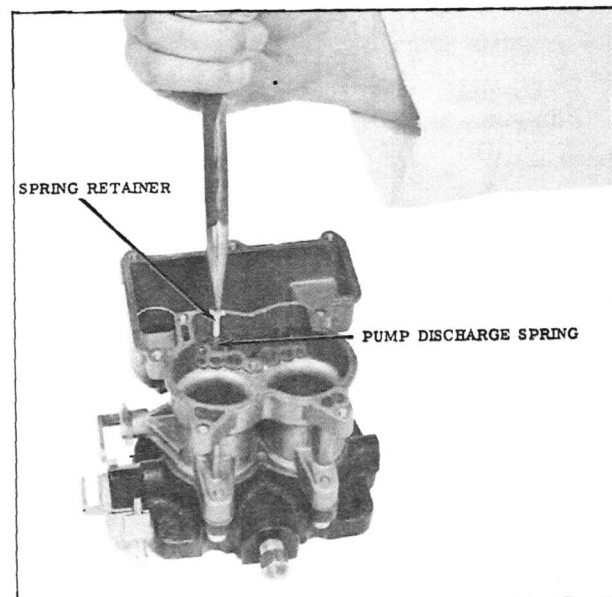

Fig. 23 Pump Discharge Spring and Retainer

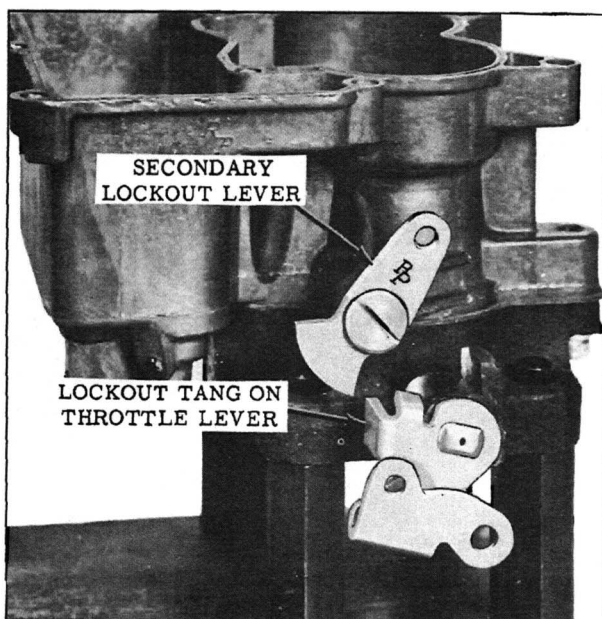

Fig. 24 Secondary Lockout Lever (Front Carburetor)

THROTTLE FLANGE DISASSEMBLY

1. (Center Carburetor Only). Remove idle adjusting needles and springs from throttle flange for cleaning and inspection.

NOTE: The throttle flange is serviced as a unit with the throttle levers. No attempt should be made to remove the throttle valves or shafts from the carburetor throttle flange, as it may be impossible to again assemble the throttle valves correctly in relation to the vacuum advance and idle discharge orifices.

CLEANING AND INSPECTION

CLEANING OF PARTS

Carburetor should not be cleaned in any solution other than a cold immersion type cleaner. Hot type cleaners may affect the sealing properties of dichromate coating.

1. Thoroughly clean carburetor castings and metal parts in carburetor cleaning solvent.
2. Do not immerse vacuum diaphragm unit or diaphragm switch in any type of cleaner. Cleaning of these units should not be necessary.
3. Rinse parts in a clear rinsing solution.
4. Clean pump plunger in clean gasoline only.
5. Blow all passages in castings dry with compressed air.

CAUTION: Do not pass drills or wires through calibrated jets or passages, as this may enlarge orifices and seriously affect carburetor calibration.

6. Clean strainer screens of dirt or lint. If they are distorted or plugged, replace.

INSPECTION OF PARTS

1. Check float for dents or wear at hinge pin holes.
2. Shake float to check for leaks.
3. Examine float needle and seat. If needle is grooved replace with a new float needle, seat and gasket assembly.
4. Inspect idle adjusting needles for burrs or ridges.
5. Check body upper and lower surfaces to see that sealing beads are not damaged. Damaged beading may result in air leakage at that point.
6. Examine threads in main metering jet, power valve and distributor vacuum passages to see that they are not damaged. Check to be sure passages are open.
7. Check passages in the throttle flange to be sure they are open.

NOTE: Due to the close tolerance fit of the throttle valves and the fact the idle discharge holes are drilled in relation to proper fitting valves, the throttle flange and valve assembly should be replaced as a complete assembly if worn or damaged.

8. Inspect holes in pump rocker arm, fast idle cam and throttle shaft lever. If holes are worn excessively or out of round to the extent of improper operation of the carburetor, the worn parts should be replaced.
9. If excessive wear is noted on the steps of the fast idle cam, it should be replaced to insure proper engine operation during warm-up.
10. Inspect pump plunger leather; replace the pump plunger as an assembly if leather is creased or cracked.
11. Check vacuum diaphragm for leaks.
12. Check vacuum switch for freedom of movement.

NOTE: Vacuum switches should not be condemned if the post does not return to top of the slot, since spring pressure will only return the post to the center of the slot.

ASSEMBLY AND ADJUSTMENTS

THROTTLE FLANGE ASSEMBLY

1. (Center Carburetor Only). Install idle adjusting needles with springs finger tight. Back out needles 1-1/2 turns as a preliminary idle adjustment.
2. Invert carburetor body, place new throttle flange gasket in position and attach throttle flange. Tighten screws evenly and securely.

CARBURETOR BODY ASSEMBLY

1. Install main metering jets.

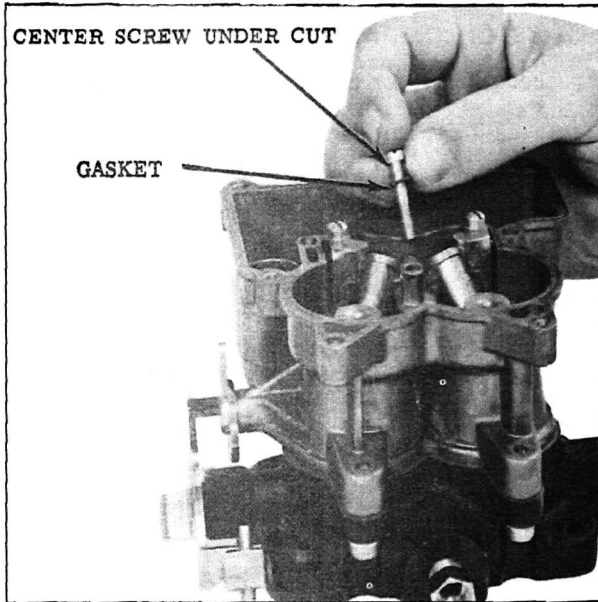

Fig. 25 Venturi Cluster Screws

2. (Center Carburetor Only). Install power valve and gasket.
3. Drop steel pump discharge check ball (3/16" dia.) into discharge hole, and replace spring and "T" shaped retainer.
4. Replace cluster and gasket, tightening screws evenly and securely. Make sure center screw is fitted with gasket to prevent pump leakage. (See Fig. 25)
5. Replace pump inlet strainer, pressing carefully into position. (See Fig. 26)
6. Drop aluminum pump intake check ball (5/32") into hole in bottom of pump well. Install pump return spring, pressing with finger to center it in counterbore of pump well.

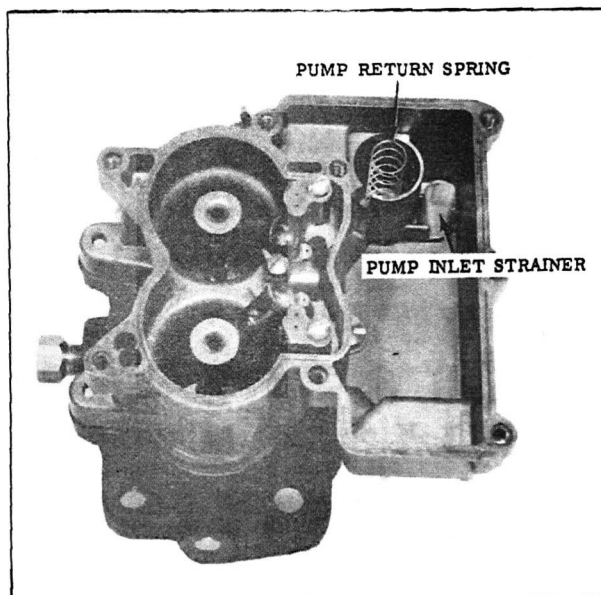

Fig. 26 Pump Strainer and Spring

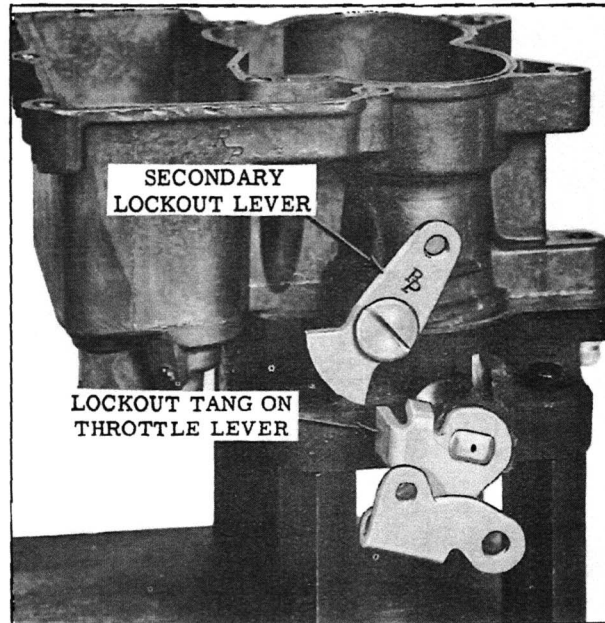

Fig. 27 Secondary Lockout Lever
(Front Carburetor)

7. (Front Carburetor Only). Install choke lock-out lever (with RP trade mark facing outward) using attaching screw. (See Fig. 27)

CHOKE ASSEMBLY (Center Carburetor Only)

1. Place new gasket in position and attach choke housing to air horn, tightening screws securely.
2. Assemble choke piston to shaft with pin, with flat cut side of piston toward choke valve as shown in Fig. 28. Install choke shaft and piston in air horn assembly.
3. Install choke valve in choke shaft with letters "RP" facing upward, and install screws loosely.
4. Install choke counterweight lever over shaft and install trip lever with attaching screw in position shown. (See Fig. 29)
5. Hold choke valve in closed position and center choke shaft, allowing .020" clearance between

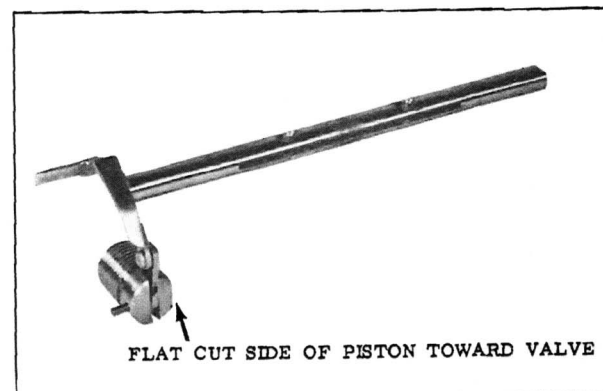

Fig. 28 Choke Piston and Shaft (Center Carburetor)

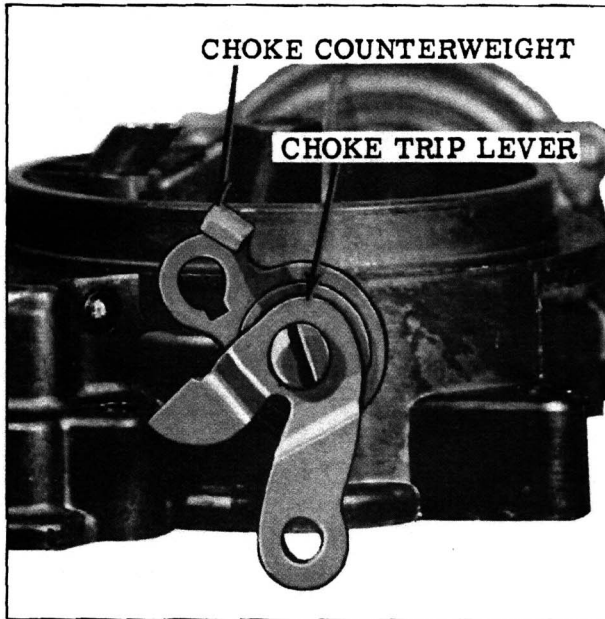

Fig. 29 Choke Counterweight and Trip Lever

counterweight lever and air horn casting. Tighten choke valve screws, then check choke valve operation for freeness. Stake choke valve screws lightly.

- Place choke baffle plate into position and install choke coil cover and gasket. Rotate cover counterclockwise until the coil picks up the choke shaft tang, and index mark on cover is set one notch lean. Attach three retainers to housing and tighten securely.

AIR HORN ASSEMBLY

- Assemble the outer pump lever and inner arm to air horn, and tighten set screw securely as shown in Fig. 30. Check to be sure shaft can rotate freely.

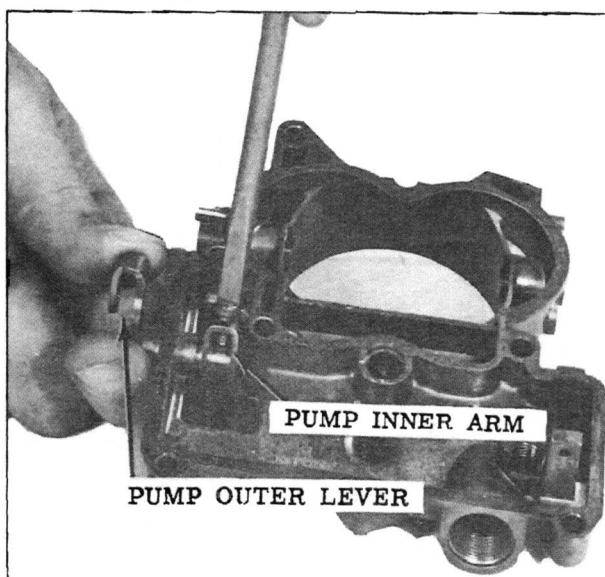

Fig. 30 Pump Inner Arm

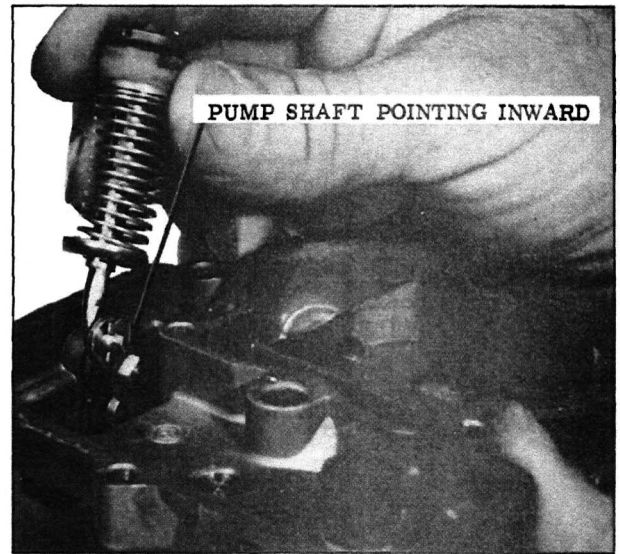

Fig. 31 Attaching Pump Assembly

- Attach pump assembly to inner arm with pump shaft pointing inward, and install retainer. (See Fig. 31)
- Install strainer screen over needle seat and then install needle seat and gasket and tighten securely.
- (Center Carburetor Only). Install power piston assembly in air horn and stake lightly in place opposite gasket sealing surface.
- Install cover gasket.
- Attach needle to float, carefully position float and insert float hinge pin.

FLOAT LEVEL ADJUSTMENT

To insure proper fuel level and sufficient entry of fuel into the carburetor bowl, two adjustments of the floats are required. They are: Float level adjustment and float drop adjustment. Since float level adjustment affects float drop setting, the float level is always adjusted first. The float setting is made with the air horn gasket in place.

Front and Rear Carburetors

- Place gauge J-5917 so it rests against the pump. Side of the power piston shaft with outer leg in line with center of float as shown in Fig. 32.
- Using BT-69 or similar tool, bend float arm as shown until float just touches bottom of gauge.

Center Carburetor

The float level on the center carburetor is $1/32''$ lower than the level on the end carburetors. In order to use existing tools, a line should be scribed on gauge J-5917 as shown on Fig. 33. This line should be used when adjusting the center carburetor.

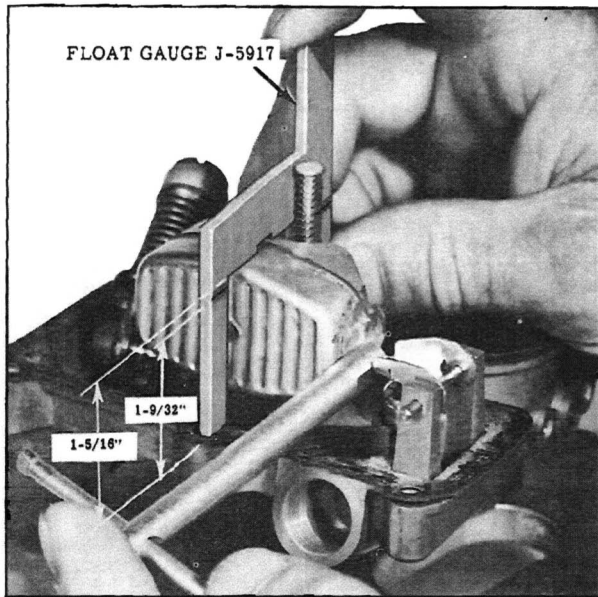

Fig. 32 Checking Float Level

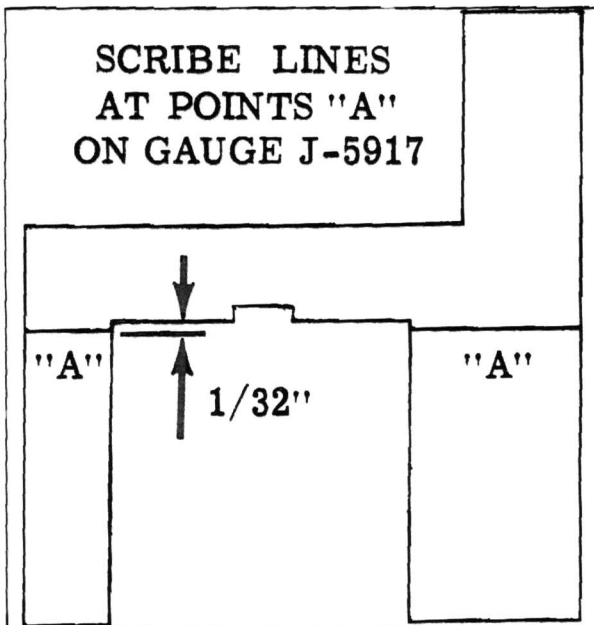

Fig. 33 Gauge J-5917 Revised

FLOAT DROP ADJUSTMENT

The float drop is measured between the air horn gasket and the bottom (lowest part) of the float. The correct distance is $1 \frac{29}{32}$ ". Check float drop with gauge J-5917 as shown in Fig. 34. If the float drop is incorrect, bend float tang toward float needle and seat to decrease drop or away from seat to increase drop.

COMPLETION OF ASSEMBLY

1. Install air horn assembly on body, being careful to guide pump plunger into well and not to bend float assembly. Check for free movement of pump plunger.
2. Install and tighten cover screws evenly and

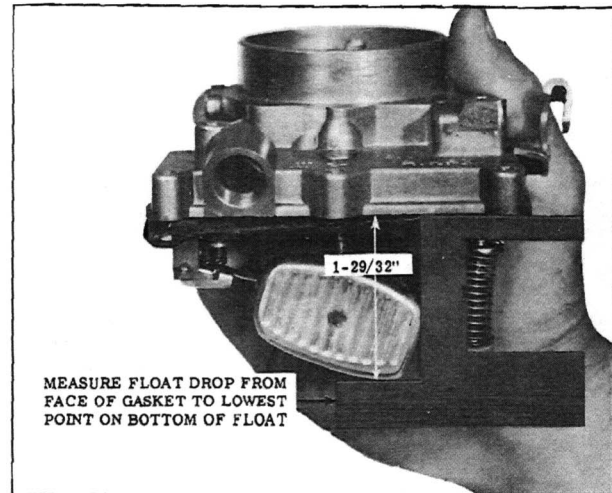

Fig. 34 Checking Float Drop

securely; note that one long screw goes in raised area of air horn casting. Leave two air horn screws out which hold vacuum switch and vacuum diaphragm on center and front carburetors.

NOTE: Vacuum switch and vacuum diaphragm to be mounted later.

3. (Center Carburetor Only). Assemble fast idle cam to choke rod.
4. (Center Carburetor Only). Install fast idle cam and choke rod assembly to counterweight and then attach the fast idle cam to the bowl. (See Fig. 35)
5. Install pump rod and retainers. (See Fig. 36 and 37)
6. Install vacuum switch on center carburetor using two retaining screws.
7. Install vacuum diaphragm on front carburetor

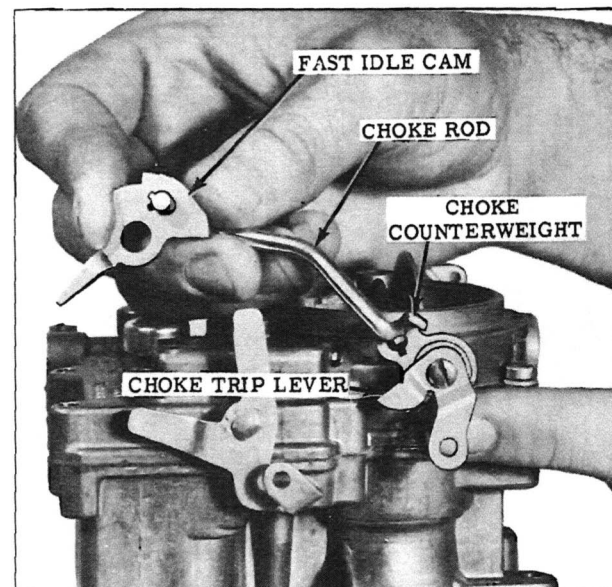

Fig. 35 Attaching Choke Rod

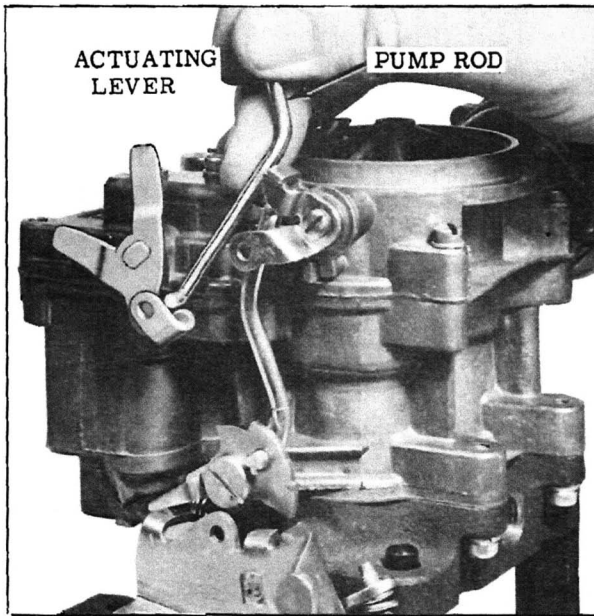

Fig. 36 Pump Rod (Center and Rear)

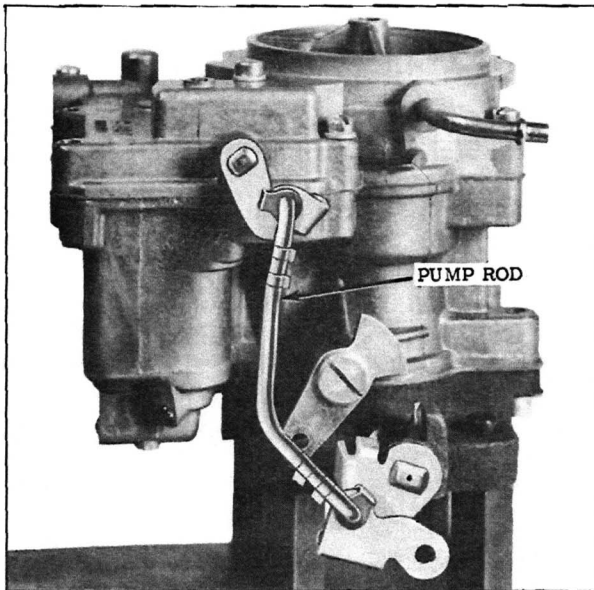

Fig. 37 Pump Rod (Front)

air horn using two retaining screws. Connect link to throttle lever from diaphragm.

8. (Front and Rear Only). Install throttle return springs to throttle lever and post on air horn. (See Fig. 38)
9. Adjust pump rod, vacuum switch, choke rod, and unloader as outlined under ADJUSTMENTS (On or off the car.)

ADJUSTMENTS (On or Off the Car)

PUMP ROD ADJUSTMENT

To insure correct fuel delivery from the pump, it is important that the pump rod be accurately set. The adjustment procedure is as follows:

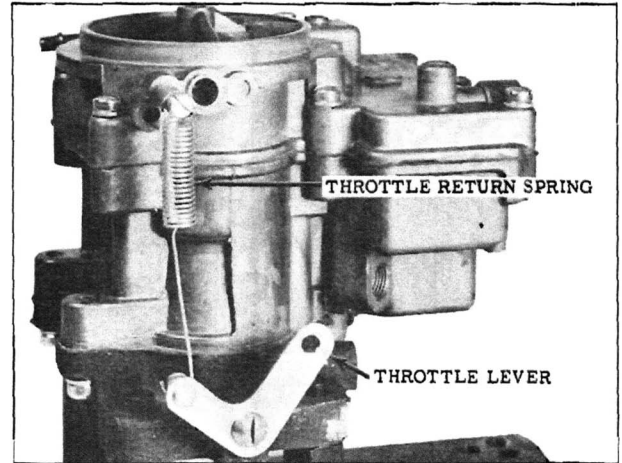

Fig. 38 Throttle Return Spring

1. Back off idle speed adjustment screw and fast idle screw until throttle valves are completely closed.
2. Hold throttle valves closed. Check distance from top of air horn to top of pump rod with gauge J-5917 as shown in Fig. 39. This distance should be $15/16$ ".
3. Using BT-18 or similar bending tool, bend lower section of pump rod to obtain proper adjustment.

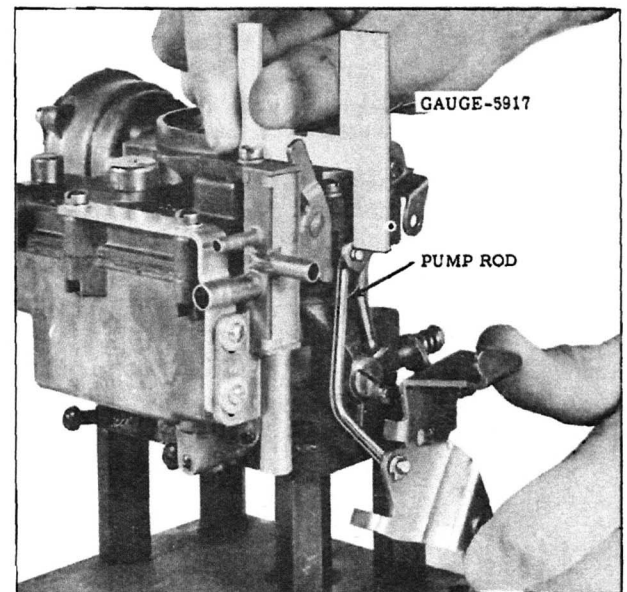

Fig. 39 Pump Rod Adjustment

VACUUM SWITCH ADJUSTMENT

CAUTION: Before making adjustment, open throttle valves wide open and then close them. This will position the switch post properly for adjustment.

1. Hold throttle valves completely closed. Check distance from the tang on the pump lever to the actuating post on the vacuum switch with a $1/32$ " drill as shown in Fig. 40.

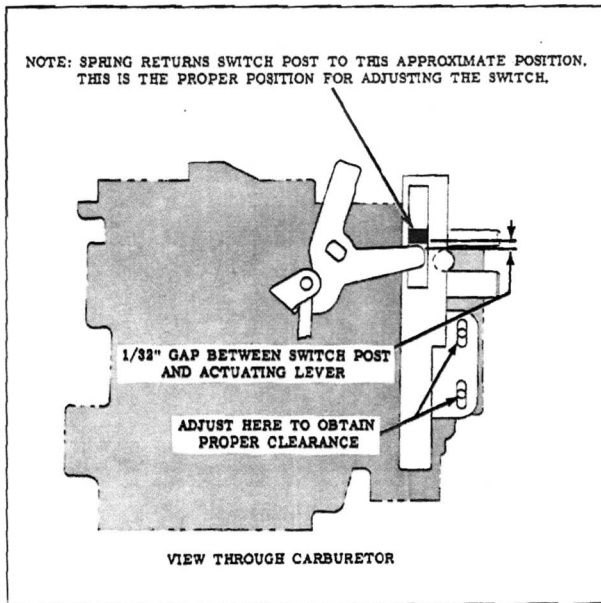

Fig. 40 Vacuum Switch Adjustment

2. Loosen two retaining screws and move switch assembly up or down to obtain the proper clearance.

CHOKE ROD ADJUSTMENT (Center Carburetor Only)

To insure proper positioning of the fast idle cam when the choke valve is in operation, the choke rod must be accurately adjusted as follows:

1. Turn the fast idle screw in until it just contacts the second step of the fast idle cam.
2. Hold the fast idle cam so the shoulder of the highest step is against the fast idle screw and check setting (.040") with small end of gauge J-5918 as shown in Fig. 41.

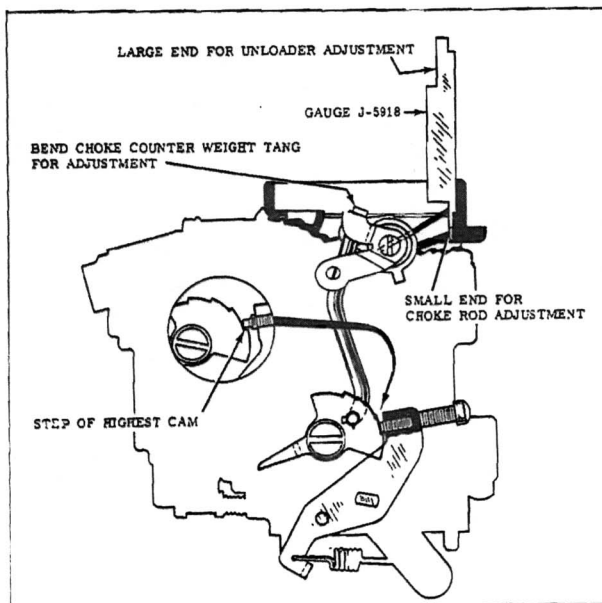

Fig. 41 Choke Rod Adjustment

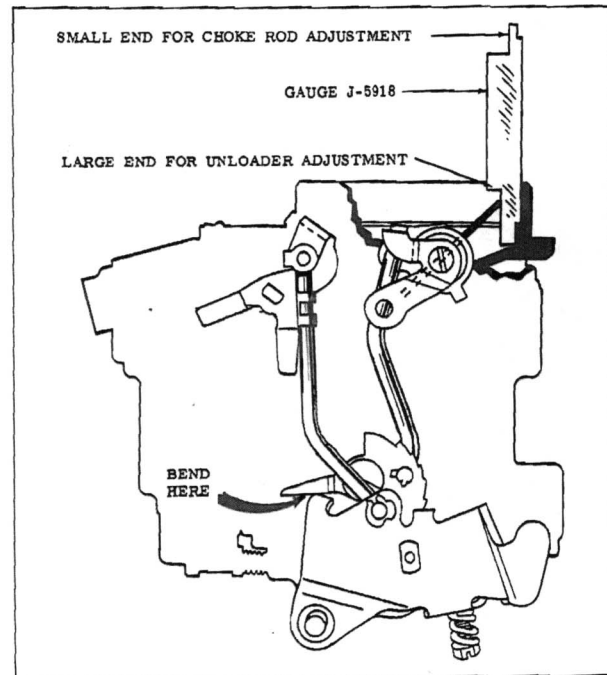

Fig. 42 Unloader Adjustment

NOTE: Be sure choke trip lever is in contact with the choke counterweight.

3. Using BT-69 or similar tool, bend counterweight tang to obtain proper adjustment.

UNLOADER ADJUSTMENT

If the engine "loads up" or becomes flooded when cold starting, it is necessary to mechanically open the choke valve a small amount to admit more air and facilitate starting. This is accomplished when the throttle lever contacts a tang on the fast idle cam at wide open throttle.

To adjust the unloader, proceed as follows:

1. With the thermostat set at index and choke trip lever in contact with choke counterweight, hold throttle lever in full open position.
2. Using large end of Tool J-5918, check clearance (9/64") between top of choke valve and inner wall of air horn as shown in Fig. 42.
3. Using BT-69 or similar tool, bend tang of throttle shaft to obtain correct adjustment.

TRANSMISSION LINKAGE ADJUSTMENT

Transmission linkage adjustment is the same as outlined in the 1957 Shop Manual, page 96, with the exception of steps 7, 8, and 9 which should read as follows:

"With throttle valves completely closed, and throttle return check holding tool in place, there should be .030" clearance between the bellcrank arm and the bellcrank stop, as shown in Fig. 43."

This eliminates the use of Tool 33-67 for bellcrank adjustment on the three 2-barrel installation ONLY.

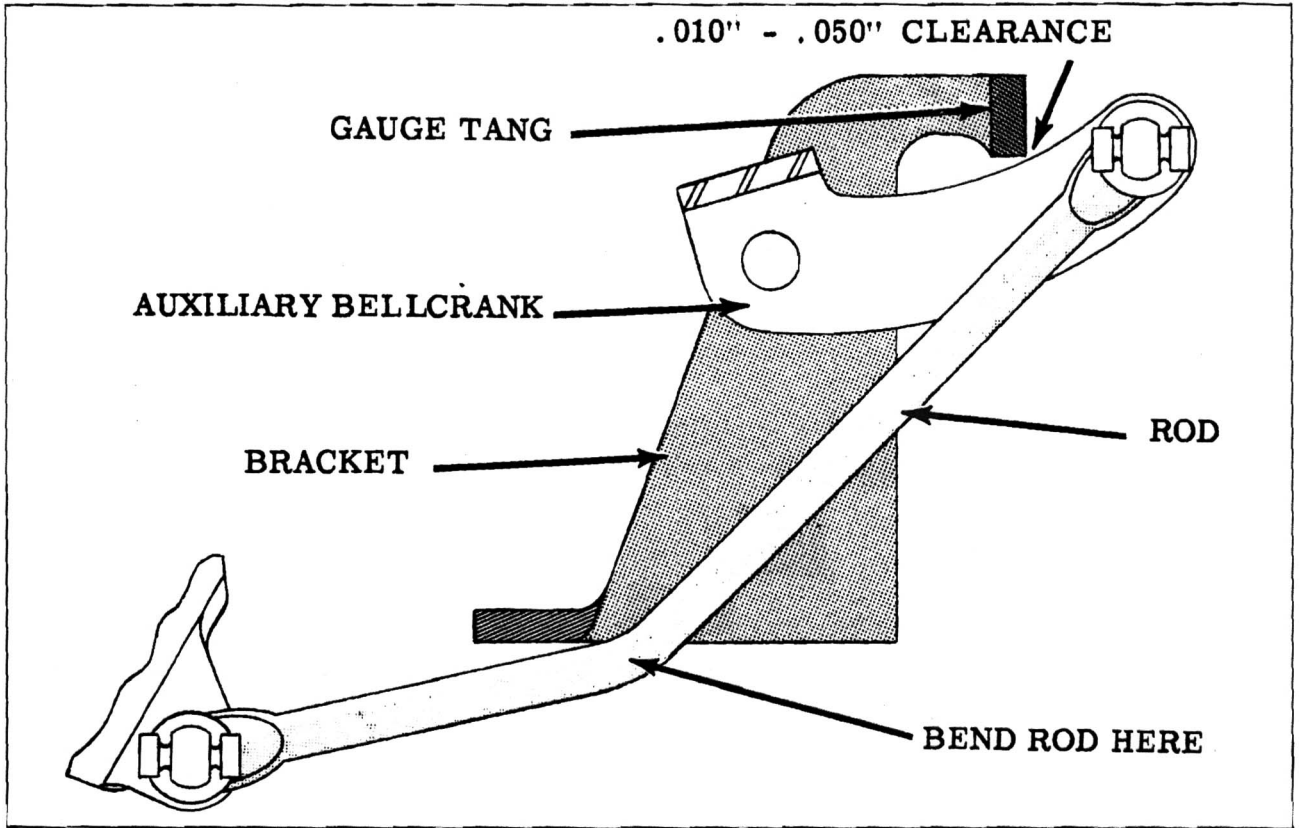

Fig. 43 Bellcrank Adjustment