

AUTOMOBILE MANUFACTURERS ASSOCIATION CONSOLIDATED SPECIFICATION QUESTIONNAIRE

MAKE OF CAR:	BUICK	MODEL NAME	SYMBOL
COMPANY:	BUICK MOTOR DIVISION GENERAL MOTORS CORPORATION FLINT, MICHIGAN	Special Century Super Roadmaster	Series 40 Series 60 Series 50 Series 70
MODEL YEAR:	1955	DATE	November 19, 1954

TABLE OF CONTENTS

General Specifications.....	1	Frame.....	16
Engine.....	2	Front Suspension.....	16
Electrical.....	8	Steering.....	17
Drive Units.....	12	Rear Suspension.....	18
Brakes.....	15	Body.....	19
Index.....	24		

- NOTES: 1. The specifications set forth herein are those in effect at the date of compilation and are subject to change without notice.
 2. All specifications are standard for the models under which they are listed unless otherwise indicated.
 3. All dimensions are nominal engineering dimensions unless otherwise indicated.
 4. Unless otherwise indicated, specifications apply to 5 or 6 passenger, 4-door sedan or equivalent.

GENERAL SPECIFICATIONS

Model	Series 40	Series 60	Series 50	Series 70
Wheelbase	122		127	
Tread	Front	59.0		
	Rear	59.0	62.2	
Maximum Overall Dimensions	Length (L-103)	206.7		
	Width (W-103)	76.2		
	Height (H-101)	***60.4	60.6	62.5
Steering ratio—overall	26.7:1		24.1:1	
Turning diameter (curb to curb)	47.6'		43.0'	
Shipping weight*	3742	3807	4111	4278
Transmission— (Specify standard, optional, not avail.)	Conventional	Standard		
	Overdrive	None		
	Automatic	Optional		Standard
Axle ratio	Conventional	3.9		
	Overdrive	None		
	Automatic	3.6	3.4	
Tire size	***7.10-15	***7.60-15		***8.00-15
Engine Dyn.	Type	90°V		
	No. of cylinders	8		
	Valve arrangement	In-Head		
	Bore and stroke	3.625 x 3.20	4.000 x 3.20	
	Piston displacement, cu. in.	264.0	322.0	
	Standard compression ratio	8.4	9.0	
	Maximum bhp at engine rpm	188 @ 4800	236 @ 4600	
Maximum torque at rpm	256 @ 2400	330 @ 3000		

*Standard car weight, not including gas and water. (Estimated)
 **7.60-15 available as optional equipment.
 ***When 7.60-15 tires are specified, dimensions are same as Series 60.
 ****Tubeless tires standard equipment, except when wire wheels are specified.

AMA Consolidated Specification Questionnaire

MAKE OF CAR BUICK **MODEL YEAR** 1955

MODEL	Series 40	Series 60	Series 50	Series 70
--------------	-----------	-----------	-----------	-----------

ENGINE—GENERAL

Type	V, In-line, other Angle of V	V 90°			
No. of cylinders		8			
Valve arrangement		In-Head			
Bore and stroke		3.625 x 3.20	4.00 x 3.20		
Piston displacement, cu. in.		264	322		
Numbering system (front to rear)	L. Bank	2-4-6-8			
	R. Bank	1-3-5-7			
Firing order		1-2-7-8-4-5-6-3			
Compression ratio	Standard-Head Syn.	**7.5	**8.4	None	
	Optional-Head Dyn.	**8.4	**9.0		
Cylinders	Head Material	Cast Iron			
	Sleeve—Wet, dry, other, none	Cast Iron			
		None			
Number of mounting points	Front	Two			
	Rear	One			
Taxable horsepower	(Dia. ² x No. Cyl.) 2.5	42.05	51.20		
Advertised max. brake horsepower at engine RPM*	Standard-head				
	Optional-head Dyn.	188 @ 4800	236 @ 4600		
	With fuel (Octane and method)	Syn. Standard-Head	Regular	Premium	None
		Dyn. Optional-Head	Premium		
Max. torque (lb. ft. @ RPM)	Standard head				
	Optional-head Dyn.	256 @ 2400	330 @ 3000		
Recommended idle speed (neutral)		450			

ENGINE—PISTONS

Material	Aluminum Alloy		
Description and finish	Cam Ground - Transverse Slot Divorced Skirt - Anodized		
Weight (piston only) oz.	***16.25	19.95	
Clearance	Top land	.025	
	Skirt	Top	.0015
		Bottom	.0017
Ring groove depth	No. 1 ring	.1955	.2145
	No. 2 ring	.198	.217
	No. 3 ring	.198	.217
	No. 4 ring	None	

*Corrected as defined by SAE Engine Test Code, with the following standard power consuming accessories: Dynamometer Exhaust, Water Pump, Fuel Pump, Oil Pump, Manifold Heat Off, Manual Spark Advance, Generator (Not Charging)

**Compression ratio change obtained on Series 50 and 60 with changes in cylinder head gasket and on Series 40, with piston change.

***16.82 when equipped with Dynaflo transmission, Series 40.

AMA Consolidated Specification Questionnaire

MAKE OF CAR BUICK **MODEL YEAR** 1955

MODEL	Series 40	Series 60	Series 50	Series 70
--------------	-----------	-----------	-----------	-----------

ENGINE—RINGS

Type (top to bottom)	No. 1 oil or comp.		Compression	
	No. 2 oil or comp.		Compression	
	No. 3 oil or comp.		Oil	
	No. 4 oil or comp.		None	
No. rings above piston pin			Three	
Compression	Material		Cast Iron	
	Coating		Lubrite Type	
	Width		.078	
	Gap		.015	
	Maximum wall thickness	.181		.200
Oil	Material		Steel	
	Coating		None	
	Width		.186	
	Gap		.025	
	Maximum wall thickness		.135	
Location of expanders			Oil Ring	

ENGINE—PISTON PINS

Material	CDS 1118		
Length	3.100		3.400
Diameter	.940		
Type	Locked in rod, in piston, floating, etc.		Locked In Rod
	Bushing	In rod or piston	None
		Material	None
Clearance	In piston		.0001
	In rod		None
Direction offset in piston	None		

ENGINE—CONNECTING RODS

Material	1045 Forged Steel		
Weight (oz.)	22.16		
Length (center to center)	6.00		
Bearing	Material	Steel Backed Moraine 400 Aluminum	
	Type (cast-in or removable)	Removable	
	Effective length	.881	
	Clearance	.0011	
	End play	.007	

ENGINE—CRANKSHAFT

Material	1145 Forged Steel		
Weight (lb.)	56.7		

AMA Consolidated Specification Questionnaire

MAKE OF CAR BUICK **MODEL YEAR** 1955

MODEL	Series 40	Series 60	Series 50	Series 70
--------------	-----------	-----------	-----------	-----------

ENGINE—CRANKSHAFT (cont.)

Vibration damper type		None	Rubber Absorption	
End thrust taken by bearing (No.)		Five		
Crankshaft end play		.006		
Main bearing	Material	Steel Backed Durex - 100A		
	Type (cast-in or removable)	Removable		
	Clearance	.0013		
	Journal dia. and bearing effective length	No. 1	2.4985 x 1.250	
		No. 2	2.4985 x 1.250	
		No. 3	2.4985 x 1.250	
		No. 4	2.4985 x 1.250	
		No. 5	2.4985 x 1.765	
No. 6		None		
No. 7		None		
Direction offset from cyl. bore		None		
Connecting rod crankpin journal diameter		2.2495		

ENGINE—CAMSHAFT

Material		Forged Steel		
Bearings	Material	Steel Backed Babbitt		
	Number	Five		
Type of drive	Gear or chain		Chain	
	Crankshaft gear or sprocket material		Sprocket - C.D.S. 1140	
	Camshaft gear or sprocket material		Sprocket - Cast Iron	
	Timing chain	Make	Link Belt	
		No. of links	52	
		Width	.688	
Pitch		.500		

ENGINE—VALVE SYSTEM

Hydraulic lifters (yes, no)		Yes	
Special provision for valve rotation (intake, exhaust)		None	
Rocker ratio		1.5:1	
Operating tappet clearance (indicate hot or cold)	Intake	None	
	Exhaust	None	
Tappet clearance for timing	Intake	.004 Off Seat	
	Exhaust	.004 Off Seat	
Timing marks on fly-wheel, damper, other		Fan Driving Pulley	Harmonic Balancer

AMA Consolidated Specification Questionnaire

MAKE OF CAR BUICK **MODEL YEAR** 1955

MODEL	Series 40	Series 60	Series 50	Series 70
--------------	-----------	-----------	-----------	-----------

ENGINE—VALVE SYSTEM (cont.)

Timing	Intake	Opens (°BTC)	25°		28°	
		Closes (°ABC)	67°	77°	79°	
	Exhaust	Opens (°BBC)	70°		75°	
		Closes (°ATC)	42°			
Intake	Material		Nickel - Chrome Alloy Steel			
	Overall length		4.704			
	Actual overall head dia.		1.750			
	Angle of seat		45°			
	Seat insert material		None			
	Stem diameter		.3720			
	Stem to guide clearance		.0025			
	Lift		.358	.378		
	Outer spring press. and length	Valve closed (lb. @ in.)	40.5 - 45.5 1.500			
		Valve open (lb. @ in.)	85 - 91 1.142	88 - 94 1.122		
	Inner spring press. and length	Valve closed (lb. @ in.)	21.5 - 26.5 1.530			
		Valve open (lb. @ in.)	53 - 59 1.172	55 - 61 1.152		
	Exhaust	Material		MS-201, 2155N or EMS-31		
		Overall length		4.704		
		Actual overall head dia.		1.375		
Angle of seat		45°				
Seat insert material		None				
Stem diameter		.3714				
Stem to guide clearance		.0030				
Lift		.350	.378			
Outer spring press. and length		Valve closed (lb. @ in.)	40.5 - 45.5 1.500			
		Valve open (lb. @ in.)	84 - 90 1.150	88 - 94 1.122		
Inner spring press. and length		Valve closed (lb. @ in.)	21.5 - 26.5 1.530			
		Valve open (lb. @ in.)	52 - 58 1.180	55 - 61 1.152		

ENGINE—LUBRICATION SYSTEM

Type of lubrication (splash, pressure, nozzle)	Main bearings	Pressure
	Connecting rods	Pressure
	Piston pins	Splash
	Camshaft bearings	Pressure
	Tappets	Pressure
	Timing gear or chain	Drip From Front Camshaft Bearing
	Cylinder walls	Splash and Nozzle

AMA Consolidated Specification Questionnaire

MAKE OF CAR BUICK **MODEL YEAR** 1955

MODEL	Series 40	Series 60	Series 50	Series 70
--------------	-----------	-----------	-----------	-----------

ENGINE—LUBRICATION SYSTEM (cont.)

Oil pump type	Gear
Normal oil pressure (lb. @ rpm)	35 @ 1600
Oil pressure gage type (electric or mechanical)	Mechanical
Type oil intake (floating, stationary)	Stationary
Oil filter type (full flow, partial flow)	Full Flow
Capacity of crankcase, less filter—refill (qt.)	6
Oil grade recommended (SAE viscosity and temperature range)	Anticipated Temp.
	Not Lower Than + 32° F
	Not Lower Than + 10° F
	Not Lower Than - 10° F
Oil type recommended	SAE Viscosity
	SAE Multi-Viscosity
	Heavy Duty

ENGINE—FUEL SYSTEM

Recommended fuel	Standard-head	Syn.	Regular	Premium	None
	Optional-head	Dyn.		Premium	
Fuel Tank	Capacity (gals.)			19	
	Filler Location			Left Rear Fender	
Fuel Filter	Type			Metal - Sintered Bronze Element	
	Location			At Carburetor	
	Type (elec. or mech.)			Mechanical	
Fuel pump	Location			Right Side Of Engine - Near Front	
	Pressure range			5 Pounds	
	Vacuum booster (std., optl., none)			Standard	
	Make			Carter, Stromberg or Rochester	
	Model number		*WCD	**WCFB	
	Number used			One	
Carburetor	Type	Downdraft, side inlet, other		Downdraft	
		Single or dual	2 bbl.	1 bbl.	
	Intake manifold heat control (manual, auto., none)				Automatic
	Automatic choke type (integral, other)			Integral	
	Air cleaner type	Standard		Heavy Duty Oil Bath	
		Optional		None	

ENGINE—EXHAUST SYSTEM

Type (single, single with cross-over, dual, other)	Single With Cross-Over
Muffler type (rev. flow, str. thru, sep.resonator)	Dynamic Flow
Exhaust pipe dia.	Branch
	Main
Tail pipe diameter	2.00 2.50 2.12

*Stromberg AAVB-267

**Rochester 4G

AMA Consolidated Specification Questionnaire

MAKE OF CAR BUICK **MODEL YEAR** 1955

MODEL	Series 40	Series 60	Series 50	Series 70
--------------	-----------	-----------	-----------	-----------

ENGINE—COOLING SYSTEM

Type (pressure system, atmospheric, other)		Pressure System		
Radiator cap relief valve press.		7 lbs.		
Circulation thermostat	Type (choke, bypass)	By - pass		
	Starts to open at	157 - 162		
Water pump	Type (centrifugal, other)	Centrifugal		
	Number of pumps	One		
	Drive (V-belt, other)	V-Belt		
	Bearing type	Sealed, Double Row Ball Bearing		
By-pass recirculation type (internal, external)		Internal		
Radiator core type (cellular, tube and fin)		Cellular		
Cooling system capacity	With heater (qt.)	*18	20.0	
	Without heater (qt.)	**16.5	18.5	
Water jackets full length of cylinder (yes, no)		No		
Water all around cylinder (yes, no)		Yes		
Radiator hose	Lower	Number and type (molded, straight)	One - Molded	
		Inside diameter and length	Dia. 1.562	
	Upper	Number and type (molded, straight)	One - Molded	
		Inside diameter and length	Dia. 1.562	
	By-pass	Number and type (molded, straight)	None	
		Inside diameter and length	None	
Drive belts	Fan	Number used	***One	
		Angle of V	36°	
		Outside length	52.7	
		Width	.380	
	Generator	Angle of V	***	
		Outside length	***	
		Width	***	
		Fan		Fan and Water Pump Bearing Shown Above
Number of blades and spacing		Four, 76° - 104°		
Diameter		18 inches		
Ratio—fan to crankshaft revolutions		.92:1		
Bearing type		Fan and Water Pump Bearing Shown Above		

*When equipped with Dynaflo Transmission, Series 40, 60 & 50, 20 Qts.

**When equipped with Dynaflo Transmission, Series 40, 60 & 50, 18.5 Qts.

***One belt is used for both fan and generator.

AMA Consolidated Specification Questionnaire

MAKE OF CAR BUICK **MODEL YEAR** 1955

MODEL	Series 40	Series 60	Series 50	Series 70
--------------	-----------	-----------	-----------	-----------

ELECTRICAL—SUPPLY SYSTEM

Battery	Make and Model		Delco-Remy - 3 KM 60-W
	Voltage Rtg. & Plates/cell		12-9
	SAE Designation & Amp Hr. Rtg		60
	Location		Left Front Fender Skirt - Under Hood
	Terminal grounded		Negative
Generator	Make		Delco-Remy
	Model		1102008
	Type		Shunt
	Ratio—Gen. to Cr/s rev.		2.17:1
Regulator	Make		Delco-Remy
	Model		1118825
	Type		Voltage & Current Control
	Cutout relay	Closing voltage @ generator rpm	11.8 - 13.6 - Adjust to 12.8
		Reverse current to open	-1 to -6
	Regulated	Voltage	14-15 - Adjust to 14.5
		Current	27 - 33 - Adjust to 30
	Min. Gen. rpm required		2300 (Hot)
	Voltage test conditions	Temperature	150° F.
		Load	Run 15 Minutes at 1-10 Amps.
Other		Battery Must Be In Circuit For Voltage Check	

ELECTRICAL—STARTING SYSTEM

Starting motor	Make		Delco-Remy
	Model		1107621
	Rotation (drive end view)		Clockwise
	Engine cranking speed		160 R.P.M. (Approx.)
	Test conditions		Engine At Operating Temperature
	Lock test	Amps	47.0
		Volts	5.1
		Torque (lb. ft.)	12
	No load test	Amps	95
		Volts	10.2
RPM (min.)		4000	
	Switch (solenoid, manual)		Solenoid
Motor control	Starting procedure		<ol style="list-style-type: none"> 1. Turn ignition switch to "on". 2. Depress accelerator.

AMA Consolidated Specification Questionnaire

MAKE OF CAR BUICK **MODEL YEAR** 1955

MODEL	Series 40	Series 60	Series 50	Series 70
--------------	-----------	-----------	-----------	-----------

ELECTRICAL—STARTING SYSTEM (cont.)

Motor drive	Engagement type		Solenoid With Over Running Clutch
	Pinion meshes (front, rear)		Front
	Number of teeth	Pinion	9
		Flywheel	180
Flywheel tooth face width		.573	

ELECTRICAL—IGNITION SYSTEM

Coil	Make		Delco-Remy
	Model		*1115081
	Amps	Engine stopped	4.5
Engine idling		2.5	
Distributor	Make		Delco-Remy
	Model		1110849
	Spark advance data (at distributor shaft)	Centr. advance start (rpm)	0° - .6° @ 300
		Centr. advance max. deg. @ rpm	11° - 13.5° @ 1750
		Vacuum advance start (in. Hg.)	6.5 - 8.5
		Vac. adv. (max. deg. @ in. Hg.)	10.5 @ 12.0
	Breaker gap (in.)		** .0125 - .0175
	Cam angle (deg.)		Usage Not Recommended By Buick
Breaker arm tension (oz.)		19 - 23	
Timing	C/S deg. @ rpm		5 BTC
	Mark location		Fan Drive Pulley Harmonic Balancer
	Cylinder numbering system (see page 2)	Front to Rear	
		Left Bank, 2-4-6-8 Right Bank, 1-3-5-7	
Firing order (see page 2)		1-2-7-8-4-5-6-3	
Spark plug	Make and model		A.C. 44-5
	Thread (mm)		14
	Tightening torque (lb. ft.)		25
	Gap		.030 - .035
Cable	Conductor type		Stranded Copper
	Insulation type		Neoprene
	Spark plug protector		Neoprene Boot & Sheet Metal Cover

ELECTRICAL—SUPPRESSION

Description	Distributor	10,000 ohm Resistance Rotor
	Coil	.33 Micro-Farad Condenser
	Generator	.33 Micro-Farad Condenser
	Voltage Regulator	.50 Micro-Farad Condenser

*To be used in series with resistance unit 1927809.

**Dwell Meter for setting point opening is not recommended.

AMA Consolidated Specification Questionnaire

MAKE OF CAR BUICK **MODEL YEAR** 1955

MODEL	Series 40	Series 60	Series 50	Series 70
--------------	-----------	-----------	-----------	-----------

ELECTRICAL—INSTRUMENTS AND SWITCHES

Speed-ometer	Make	A.C.		
	Trip odometer (yes, no)	**No	Yes	
	Charge indicator—type	Ammeter		
	Temperature indicator—type	Bourdon Tube		
	Oil pressure indicator—type	Pressure Expansion		
	Fuel indicator—type	Electric		
Ignition switch	Identify positions in order and circuits controlled	Center - Ignition and Accessories On 1st Position Counterclockwise-Ignition & Accessories Off & Locked 1st Position Clockwise - Ignition and Accessories Off-Not Locked		
	Provision for illumination	None		
	Location	Right of Steering Column		
	Theft protection type	Inaccessible Due to Location		
Main lighting switch	Identify positions and lights controlled	1st Position Out - Park and Tail Lights 2nd Position Out - Head Lights and Tail Lights Fully Counterclockwise - Instrument and Map Lights Off 1st Position Clockwise - Map Lights on 2nd Position Clockwise - Map Lights and Instrument Lights On 3rd Position Clockwise - Instrument Lights On*		
	Locations and lamps controlled	Dome Lamp ***** Trunk Lamp Glove Compartment Parking Brake **Mercury Switch In Lamp Mechanically Operated By Door ***On Parking Brake Release Bracket		
Other switches	Locations and devices controlled	Directional Signal Left Side of Steering Column Back-Up Lights ***Base of Steering Column*** St. Col. between Dash & Inst. Panel		
	Heat. & Defroster	Instrument Panel Near Heater & Defroster Controls		
	Make	Trico		
Windshield wiper	Type	Vacuum		
	Vacuum booster provision	Yes		
	Washer provision	***Yes		
Horn	Type	Vibrator		
	Number used	2		
	Amp draw (each)	Left Horn 9.5 - Right Horn 10.5		

*Further rotation clockwise dims instrument lights.

**Optional at Extra Cost Series 40.

***Optional at Extra Cost Series 40-60-50.

****Series 40-60-50 Dynaflo same as Series 70.

41, 46R, 61, 66R
46C, 66C
52-72
56R, 76R
56C, 76C

Manual
Dome Light
Rear of Left Rear Arm Rest
Left Center Pillar
Dome Light
Rear of Left Rear Arm Rest

Automatic
Front Pillars
Front Pillars
Front & Center Pillars
Front Pillars
Front Pillars

AMA Consolidated Specification Questionnaire

MAKE OF CAR BUICK **MODEL YEAR** 1955

MODEL	Series 40	Series 60	Series 50	Series 70
--------------	-----------	-----------	-----------	-----------

ELECTRICAL—LAMP BULBS

Give quantity used and trade number, e.g., Headlamp 2-4030.
Indicate accessories which are not standard equipment by an asterisk following the numbers.

Headlamp	2-4400			
Headlamp beam indicator	1-53			
Parking light	2-1034			
Tail light	2-1034			
Stop light	Use Same Bulb as Tail Light			
Direction indicator	Front	Use Same Bulb as Parking Light		
	Rear	Use Same Bulb as Tail Light		
	Tell-Tale	2-53		
License plate light	2-67			
Instrument light	4-57	1	7-57	
Ignition lock light	None			
Map light	1-89			
Dome light	1-1004			
Clock light	1-57*		1-57	
Radio dial light	1-57*			
Glove compartment light	1-57X			
Courtesy light	None			
Trunk compartment light	1-89*		1-89	
Other Back-up Light		2-1073*		2-1073
Brake Indicator	1-57*		1-89*	1-89
Dyn. Quadrant Light**		1-57*		1-57

ELECTRICAL—FUSE & CIRCUIT BREAKER DATA

*Accessory at Extra Cost.
**Included in Dynaflo Package.

Use trade number of fuse, e.g., SFE-10. Indicate circuit breaker by ampere capacity suffixed by letters "C.B.", e.g., 30 C.B. Where fuse or circuit breaker protects multiple circuits indicate first use by a letter and repeat the same letter for all units protected by the same fuse or circuit breaker, e.g., Parking light: SFE-10 (a), Direction indicator: same as (a).

Headlamp	25 @ 3 Min. C.B. (a)			
Headlamp beam indicator	Same as (a)			
Parking light	Same as (a)			
Tail light	Same as (a)			
Stop light	SFE-9 (b)			
Direction indicator	Same as (b)			
License plate light	Same as (a)			
Instrument light	Same as (a)			
Ignition light	None			
Map light	Same as (a)			
Dome light	SFE-20 (c)			
Clock	*AGA-2	AGA-2	AGA-2	
Clock light	*Same as (a)	Same as (a)	Same as (a)	
Radio	*7.5 Special			
Glove compartment light	AGA-2			
Courtesy light	None			
Trunk compartment light	*Same as (c)	Same as (c)	Same as (c)	
Other Brake Indicator		*SFE-9 (d)		SFE-9 (d)
Heater & Blower	*SFE-9			
Back-Up Lamps	*Same as (d)		Same as (d)	
Cigar Lighter	Special			
Antenna Motor	*AGC-15			
Electric Window & Seat Controls	-#40 C.B.			
Air Conditioner	*20-SFE Blower; 6-SFE Temp. Control			

AMA Consolidated Specification Questionnaire

MAKE OF CAR BUICK **MODEL YEAR** 1955

MODEL	Series 40	Series 60	Series 50	Series 70
--------------	-----------	-----------	-----------	-----------

DRIVE UNITS—CLUTCH (PEDAL OPERATED)

Make		Buick		None	
Type (dry or wet plate)		Dry Plate		None	
In combination with fluid coupling (yes, no)		No		None	
Semi-centrifugal (yes, no)		No		None	
Type pressure plate springs		Crown	Coil	None	
Total plate pressure (lb.)		1350	1680	None	
No. of clutch driven discs		One		None	
Clutch facing	Material		Woven	None	
	Inside diameter	6	6.5	None	
	Outside diameter	10	10.5	None	
	Total eff. area (sq. in.)	100.6	106.8	None	
	Thickness		.125 + .003		None
	Number required		Two		None
	Engagement cushioning method		Spring		None
	Release bearing	Type	Ball		None
		Method of lubrication	Sealed		None
	Torsional damping	Method (springs, other)	Spring		None
Frict. mat.		Woven Material		None	

DRIVE UNITS—TRANSMISSIONS

Conventional (std. or opt.)	Standard	None
Conventional with overdrive (std. or opt.)	None	
Automatic (std. or opt.)	Optional	Standard

DRIVE UNITS—CONVENTIONAL TRANSMISSION

Number of forward speeds		Three		None
Transmission ratios	In first	2.67	2.3933	None
	In second	1.66	1.5259	None
	In third	1.00	1.00	None
	In fourth	None		None
	In reverse	3.02	2.534	None
Constant mesh gears in 2nd (yes, no)		Yes		None
Spur gear used in (indicate speeds)		None		None
Helical gears used in (indicate speeds)		All		None
Synchronous meshing in 2nd and 3rd gears (yes, no)		Yes		None

AMA Consolidated Specification Questionnaire

MAKE OF CAR BUICK **MODEL YEAR** 1955

MODEL	Series 40	Series 60	Series 50	Series 70
--------------	-----------	-----------	-----------	-----------

DRIVE UNITS—CONVENTIONAL TRANSMISSION (cont.)

Lubricant	Capacity (pt.)		1.75	2.50	None
	Type recommended		"Multi-Purpose" Gear Lubricant		
	SAE viscosity number	Summer	SAE 90		
		Winter	SAE 90		
		Extreme cold	SAE 90		

DRIVE UNITS—CONVENTIONAL TRANSMISSION WITH OVERDRIVE

For transmission data see conventional transmission section

Overdrive	Type (planetary or other)		None			
	If planetary, No. of pinions					
	Manual lockout (yes, no)					
	Downshift accelerator control (yes, no)					
	Minimum cut-in speed					
	Gear ratio					
	Lubri- cant	Capacity (O.D. only)				
		Separate filter (yes, no)				
		Type recommended				
		SAE viscosity number	Summer			
Winter						
	Ext. cold					

DRIVE UNITS—AUTOMATIC TRANSMISSION

Trade name	*Variable Pitch Dynaflo
Type (fluid coupling with gears, torque converter with gears, other)	Torque Converter With Gears
Manual selector positions, left to right (show symbols and define, e.g., N- Neutral)	P-Park N-Neutral D-Drive L-Low R-Reverse
List gear ratios in each drive position (range)	D- 1 x Converter Ratio L- 1.82 x Converter Ratio R - 1.82 x Converter Ratio
Shifting within drive position range by accelerator control and speed limiting governor (yes, no)	Yes Stator Blades Shift At Full Throttle Position
By governor—forced shift (yes, no)	No
Downshift of gears in high range possible up to (mph)	Manual Downshift Not Recommended Over 40 M.P.H.

*Optional At Extra Cost on Series 40, 60 & 50.

AMA Consolidated Specification Questionnaire

MAKE OF CAR BUICK **MODEL YEAR** 1955

MODEL	Series 40	Series 60	Series 50	Series 70
--------------	-----------	-----------	-----------	-----------

DRIVE UNITS—AUTOMATIC TRANSMISSION (cont.)

Torque convertor	Number of elements		4	
	Max. ratio at stall at engine rpm		2.1 @ 1300 2.5 @ 2300	
	Mechanical lockup	Provided (yes, no)	No	
		Speed range	None	
		Releases at (speed range, mph)	None	
	Type of cooling (forced air, oil cooler and type, other)		Water Cooled	
Anti-creep device (yes, no)		No		
Lubricant	Capacity—refill (pt.)		20	
	Type recommended		**	
	Grade	Summer	Type "A"	
		Winter	Type "A"	
Extreme cold		Type "A"		

DRIVE UNITS—PROPELLER SHAFT

Number used		One	
Type (exposed, torque tube)		Torque Tube	
Outer diameter x length* x wall thickness	Conventional trans.	2.62 x 60.9 x .065	2.62 x 64.9 x .065
	Overdrive trans.	None	
	Automatic trans.	2.62 x 60.9 x .065	2.62 x 64.9 x .065
Intermediate bearing	Type (plain, anti-friction)	None	
	Lubri. (fitting, prepack)	None	
Universal joints	Make	Saginaw or Spicer	
	Number used	One	
	Type (ball and trunion, cross, other)	Cross	
	Bearing	Type (plain, anti-friction)	Steel Bushing
Lubric. (fitting, prepack)		Lubricated By Transmission	
Drive taken through (torque tube or arms, spring)		Torque Tube	
Torque taken through (torque tube or arms, springs)		Torque Tube	

*Centerline to centerline of joints or centerline of rear attachment point.

**Automatic transmission fluid type A, - must be identified by AQ-ATF number embossed in can or special Buick oil for Dynaflo Drive.

AMA Consolidated Specification Questionnaire

MAKE OF CAR BUICK **MODEL YEAR** 1955

MODEL	Series 40	Series 60	Series 50	Series 70
--------------	-----------	-----------	-----------	-----------

DRIVE UNITS—REAR AXLE

Type (semi-floating, other)		Semi-Floating		
Gear type (hypoid, other)		Hypoid		
Gear ratio and No. of teeth	Conventional trans.	3.9(43-11)		None
	Overdrive trans.	None		
	Automatic trans.	3.6(43-12)	3.4 (41-12)	
Pinion adjustment (shim, other)		Shim		
Pinion bearing adj. (shim, other)		None		
Lubricant	Capacity (pt.)	4.5		
	Type recommended	***Hypoid Lubricant - GM 4655M only, for complete fill		
	SAE viscosity number	Summer	90	
		Winter	90	
	Extreme cold	***80 GM 465LM		

DRIVE UNITS—WHEELS

Type (disc, other)		**Disc		
Rim (size and flange type)		15x5.50K	15x6.00L	
Attachment	Type (bolt or stud)	Bolt		
	Circle diameter	5.00"		
	Number and size	Five - 9/16 - 18		

DRIVE UNITS—TIRES

Size and ply rating	Standard	*7.10-15 4 Ply	*7.60-15 4 Ply	*8.00-15 4 Ply
	Optional	*7.60-15 4 Ply	None	
Rev/mile at 30 mph		750	735	723
Inflation press. (cold)	Front	24		
	Rear	24		

BRAKES—SERVICE

Type		Hydraulic - Internal Expanding		
Booster type		***Optional		
Effective area (sq. in.)		184.6	207.5	219.0
Percent brake effectiveness—rear		47		
Drum	Diameter	Front	12	
		Rear	12	
	Type and material	Cast Iron		

- *Tubeless tires standard equipment, except when wire wheels are specified.
- **Wire wheels available at extra cost on all series.
- ***Multi-Purpose may be used for make-up.
- ****Only when Dynaflo equipped on Series 40, 60 & 50.

AMA Consolidated Specification Questionnaire

MAKE OF CAR BUICK **MODEL YEAR** 1955

MODEL	Series 40	Series 60	Series 50	Series 70
--------------	-----------	-----------	-----------	-----------

BRAKES—SERVICE (cont.)

	Bonded or riveted			Riveted	
		Material		Moulded	Extruded
Brake lining	Primary	Size (length x width x thickness)	Front wheel	10.094 x 2.25 x .187	
			Rear wheel	10.094 x 2.50 x .250	
		Segments per shoe	One		
	Secondary	Size (length x width x thickness)	Front wheel	10.094 x 1.75 x .187	
			Rear wheel	10.094 x 2.25 x .187	
		Segments per shoe	One		
			Moulded	Extruded	
			12.969 x 2.25 x .187	12.969 x 2.50 x .250	
			12.969 x 1.75 x .187	12.969 x 2.25 x .187	
			One		
Wheel cylinder bore	Front		1.125		
	Rear		1.0		
Master cylinder bore			1.0		
Available pedal travel			7.5		
Line pressure at 100 lb. pedal load			600		
Shoe clearance adjustment			.015"		

BRAKES—PARKING

Type of control	Step On - Left Foot Operated	
Location of control	Left Side Cowl Panel	
Operates on	Rear Service Shoes	
If separate from service brakes	Type (internal or external)	None
	Drum diameter	None
	Lining size (length x width x thickness)	None

FRAME

Type and description	Double Drop, Channel X Center Cross Member, Box Type Front Cross Member.
----------------------	--

FRONT SUSPENSION

Type and description	Independent With Coil Springs
----------------------	-------------------------------

AMA Consolidated Specification Questionnaire

MAKE OF CAR BUICK **MODEL YEAR** 1955

MODEL	Series 40	Series 60	Series 50	Series 70
--------------	-----------	-----------	-----------	-----------

STEERING (cont.)

Kingpin	Inclination at camber (deg.)		0° at 7/8° Camber
	Diameter		.861 - .862
	Bearings (type)	Upper	Bushing
		Lower	Bushing
Thrust		Ball	
Wheel alignment (range and preferred)	Caster (deg.)		1/2° Positive to 3/4° Negative
	Camber (deg.)		7/8° Positive to 5/8° Negative
	Toe-in (outside tread-inches)		0 to 1/16
Steering knuckle type			Reverse Elliott
Wheel spindle	Diameter	Inner bearing	1.3735 - 1.3740
		Outer bearing	.8426 - .8431
	Thread size		13/16 - 16, LH & RH
	Bearing type		Ball

REAR SUSPENSION

Type		Coil Springs			
Drive and torq. taken through (see page 14)		Torque Tube			
Spring	Type		Coil		
	Material		High Carbon Silicon Manganese Steel 9260		
	Size (length x width x No. leaves or coil I.D.)		19.375 x .560 x 5.5	19.50 x .580 x 5.5	
	Spring rate (lb. per in.)		100	115	
	Rate at wheel (lb. per in.)		100	115	
	Normal load (lb. at rated length)		960 @ 9.562	1070 @ 9.562	
	Mounting insulation type		Rubberized Fabric		
	if leaf	No. of leaves		None	
		Covers (yes, no)		No	
		Lubricated (yes, no)		No	
		Inserts	Type and size		None
			Material		None
Shackle (comp. or tens.)		None			
Shock absorbers	Manufacturer		Delco		
	Type (direct or lever)		Lever		
	Piston diameter		1-1/2"		
Stabilizer	Type (link, linkless, frameless)		None		
	Material		None		
Track bar type			Tubular Steel Bar Mounted in Rubber		

AMA Consolidated Specification Questionnaire

MAKE OF CAR BUICK MODEL YEAR 1955

BODY—GENERAL DEFINITIONS

NOTE: Included in the dimension definitions listed on this and the following pages are those which have been proposed for adoption by the SAE. These are indicated by a number following the type of dimension, e.g., L 3. Additional dimensions have been added by the AMA Specifications Body Sub-Committee for inclusion in the Questionnaire. These are shown by an additional letter, e.g., HA. The dimensions are developed from the following basic points:

1. Front and rear seat "A" points are taken 5" forward of vertical tangent to seat back 15" from center of body.
2. Front seat is in the rear position.
3. Loaded position—5 passengers, front 300 lb., rear 450 lb., includes spare wheel, tire and tools, and full complement of gas, oil, water, etc. and tires to recommended pressure, etc.
4. C. L. (centerline).
5. D. L. O. (daylight opening, exposed glass dimension).
6. Ramp breakover angle (page 20-A) is the supplement of the included ramp angle (180° minus the included ramp angle) over which a car can pass without hanging up.

MODEL	Series 40	Series 60	Series 50	Series 70
-------	-----------	-----------	-----------	-----------

BODY—TRUNK OPENING DIMENSIONS

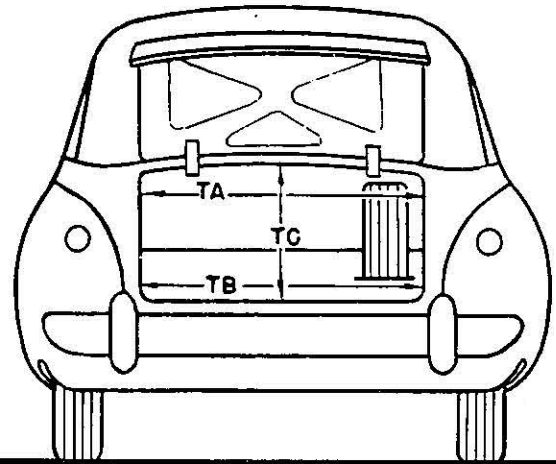
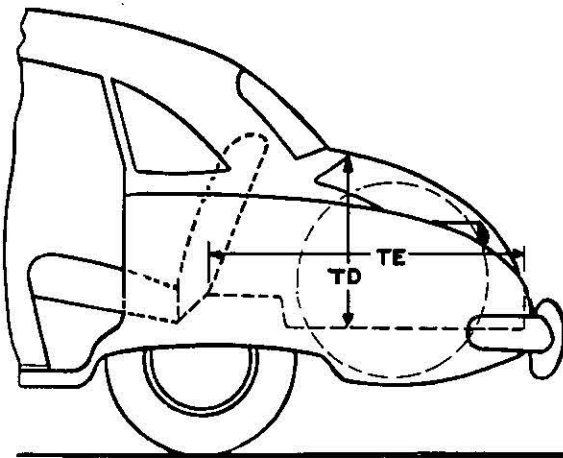

TA—Width across the top	55.6	58.7	
TB—Width across the bottom	53.0	54.6	
TC—Diagonal dimension at CL from top of opening to bottom	31.8	34.3	
TD—Vertical height of opening (floor to top, inside edge of opening)	23.4	25.2	
TE—Max. horizontal depth (forward from vertical projection of inside edge of opening)	46.0	49.0	
Position of spare tire stowage	Right Side - Longitudinal, Vertical		
Method of holding lid open	Counterbalance Spring at Trunk Lid Hinges		

AMA Consolidated Specification Questionnaire

MAKE OF CAR BUICK MODEL YEAR 1955

MODEL	Series 40	Series 60	Series 50	Series 70
--------------	-----------	-----------	-----------	-----------

BODY—HEIGHT DIMENSIONS—INTERIOR

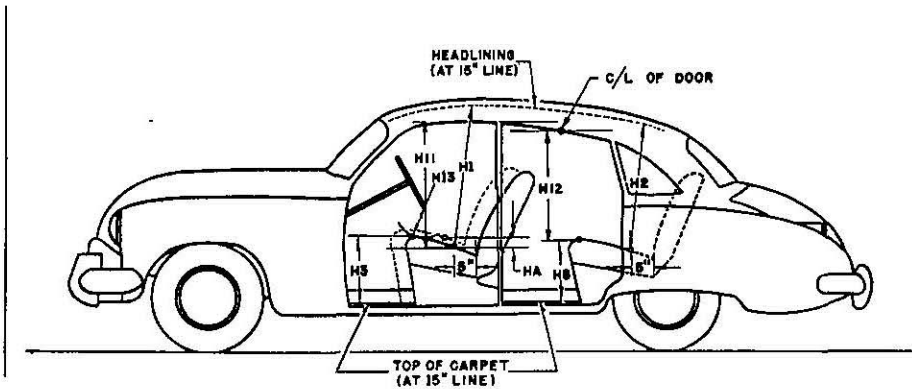

H1. Front headroom—from "A" pt. to headlining at 8° back of vertical on 15" line. (For "A" pt. see note 1, page 19)	35.6	36.6	35.9
H2. Rear headroom—from "A" pt. to headlining at 8° back of vertical on 15" line.	34.0	35.2	35.1
H3. Front seat height to floor carpet on 15" line (front edge of cushion).	12.6	13.2	13.9
H8. Rear seat height to floor carpet on 15" line (front edge of cushion).	12.4	12.1	12.7
H11. Entrance—front—cushion "A" point to bottom windcord vertical.	29.7	30.8	30.2
H12. Entrance—rear—top of cushion to bottom windcord vertical at C/L of rear door.	27.5	29.0	28.5
H13. Steering wheel clearance to seat cushion taken on arc.	5.2	5.1	4.4
HA. Front seat vertical rise at "A" pt. (inches.)	1.1	0.9	

AMA Consolidated Specification Questionnaire

MAKE OF CAR BUICK MODEL YEAR 1955

MODEL	Series 40	Series 60	Series 50	Series 70
--------------	-----------	-----------	-----------	-----------

BODY—HEIGHT DIMENSIONS—EXTERIOR

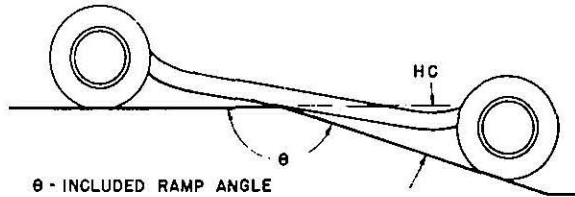
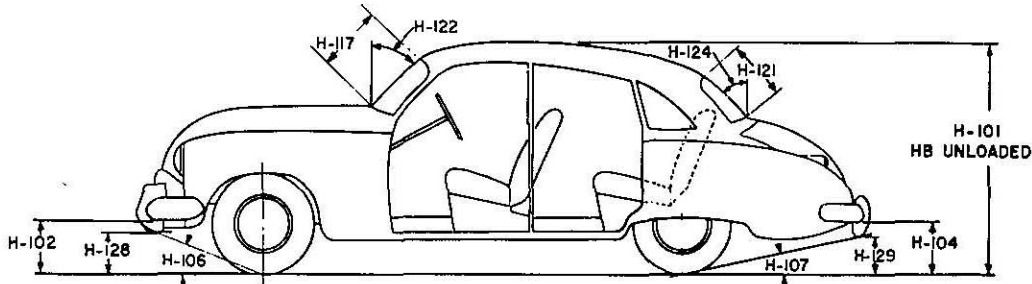

θ - INCLUDED RAMP ANGLE
H C - RAMP BREAKOVER ANGLE
(SUPPLEMENT OF INCLUDED RAMP ANGLE)

H101. Overall height.	**60.4	60.6	62.5	62.7
HB. Overall height—unloaded.	**62.0	62.2	64.1	64.3
H102. Front bumper bottom to ground at normal section.	**9.9	10.2	10.1	10.4
H104. Rear bumper bottom to ground at normal section.	**11.1	11.3	11.1	11.3
H106. Angle of approach—from the tire rolling radius to lowest point on front bumper or guard.	**24.4°	25.0°	25.0°	25.7°
H107. Angle of departure—from the tire rolling radius to lowest point on rear bumper or guard.	**12.2°	12.6°	11.1°	11.5°
HC. Ramp breakover angle.*	**13.0°	13.5°	12.9°	13.3°
H117. Windshield DLO-slant height.		17.5		18.6
H121. Backlight DLO*—Max., slant height.		16.3		16.2
H122. Windshield slope angle to vertical line on car axis.		44°		47°
H124. Backlight slope angle to vertical line on car axis.		46°		48°
H128. Ground to bottom of front bumper guard.	**18.4	18.6	18.6	18.8
H129. Ground to bottom of rear bumper guard.	**10.5	10.7	10.5	10.7
HD. Min. road clearance (location and dimension).	**6.3****		6.6***	6.8***
HE. Min. road clearance at rear axle.	**7.6	7.8		8.0

*See Notes, page 19. **When 7.60-15 Tires Are Specified, Dimensions are Same As Series 60.
Bell Housing, Frame Mid-Section, Exhaust System. *Frame Mid-Section.

AMA Consolidated Specification Questionnaire

MAKE OF CAR BUICK **MODEL YEAR** 1955

MODEL	Series 40	Series 60	Series 50	Series 70
--------------	-----------	-----------	-----------	-----------

BODY—LENGTH DIMENSIONS

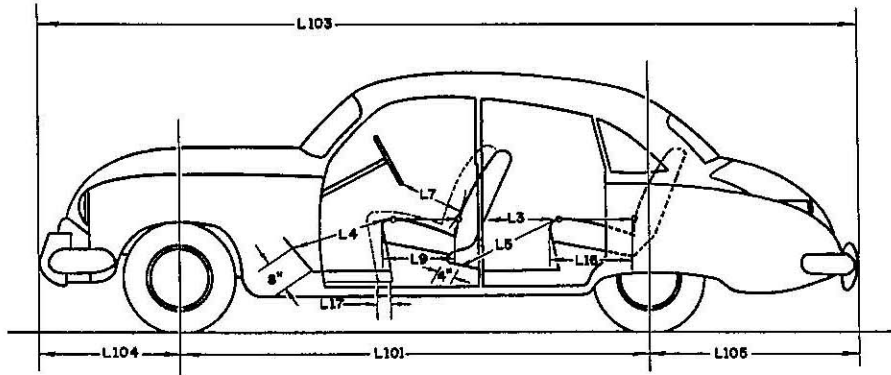

Interior	L3. Rear compartment back of front seat back to rear seat back.	32.4	34.8	35.0
	L4. Leg room—front—diagonal—ball of foot to top of seat to front seat back—15" line.	42.3	43.2	43.6
	L5. Leg room—rear—diagonal—from ball of foot to top of rear seat cushion and to seat back.	41.8	41.4	45.1
	L7. Steering wheel clearance to seat back taken on arc.	13.4	13.5	
	L9. Front seat depth (front edge to vert. tan. to seat back on 15" line).	18.6	17.5	17.9
	L16. Depth of rear seat (front edge to seat back).	18.9	17.7	17.8
	L17. Total adjustment of front seat at floor.	4.4	4.0	
Exterior	L101. Wheel base.	122	127	
	L103. Overall length (bumper to bumper inc. guards).	206.7	216.0	
	L104. Overhang—front including bumper guards.	35.4	35.4	
	L105. Overhang—rear including bumper guards.	49.3	53.6	

AMA Consolidated Specification Questionnaire

MAKE OF CAR BUICK **MODEL YEAR** 1955

MODEL	Series 40	Series 60	Series 50	Series 70
--------------	-----------	-----------	-----------	-----------

BODY—WIDTH DIMENSIONS

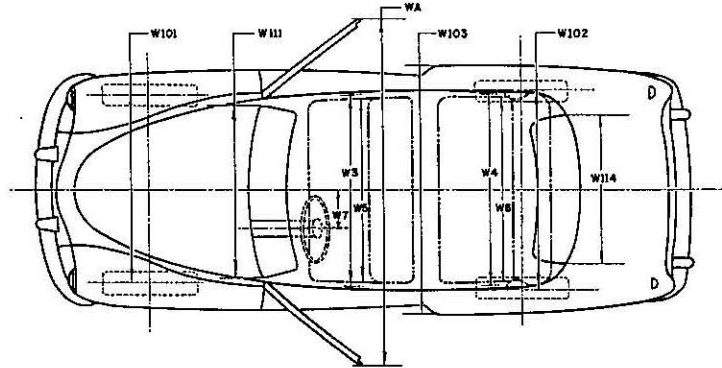

Interior	W3. Front shoulder room, at garnish moulding height or nearest interference 5" forward of seat back.	58.2	59.4	
	W4. Rear shoulder room, at garnish moulding height or nearest interference 5" forward of seat back.	56.7	58.7	
	W5. Front hip room, at top of seat 5" forward of vert. tan. to seat back.	62.5	64.9	64.7
	W6. Rear hip room, at top of seat 5" forward of vert. tan. to seat back.	62.4	65.7	
	W7. Steering wheel center to center of body.	15.1	16.2	
	W101. Front tread at ground.	59.0		
	W102. Rear tread at ground.	59.0	62.2	
Exterior	W103. Max. overall width of car including bumpers or mouldings.	76.2	80.0	
	WA. Max. overall width of car with doors open.	145.8	147.8	
	W111. Windshield DLO, max. width.	61.0	61.0	
	W114. Back window DLO, max. width.	60.0	59.8	

AMA Consolidated Specification Questionnaire

Page 23
Rev. 8-53
Rev. 12-8-54

MAKE OF CAR BUICK MODEL YEAR 1955

MODEL	Series 40	Series 60	Series 50	Series 70
--------------	-----------	-----------	-----------	-----------

BODY—MISCELLANEOUS INFORMATION

Doors hinged (front, rear)	Front			Front
	Rear			Front
Type of finish (lacquer, enamel)				Lacquer
Hood opening (front, side; semi-full, full, half)				Front - Full
Hood counterbalanced (yes, no)				Yes
Hood release control (internal, external)				External
Vent window control method (crank, friction, pivot)				Crank
Windshield (one piece, two piece; curved, flat)				One Piece - Curved
Rear window type (one piece, two piece, three piece; curved, flat)				One Piece - *Curved
Windshield glass area		1149.2		1206.0
Backlight glass area		1061.0		1069.1
Total glass area	3765.5		3739.8	4170.8

BODY—TYPES AND STYLE NAMES

Body type, number of passengers, and style names (use letter code shown below followed by passenger capacity and style name e.g., N-6 Ranchwagon)

L-6	L-6	L-6	L-6
J-6	J-6	J-6	J-6
G-6	G-6	H-6	H-6
D-6	P-6		
P-6			

Body type code

- A—Coupe—2 door flatback
- B—Coupe—2 door notchback
- C—Sedan—2 door flatback
- D—Sedan—2 door notchback
- E—Sedan—4 door flatback (4 windows)
- F—Sedan—4 door flatback (6 windows)
- G—Sedan—4 door notchback (4 windows)
- H—Sedan—4 door notchback (6 windows)
- J—Hardtop—2 door
- K—Hardtop—4 door

- L—Convertible—2 door
- M—Convertible—4 door
- N—Station wagon—2 door
- P—Station wagon—4 door
- Q—Combined passenger and utility—2 door
- R—Combined passenger and utility—4 door
- S—Sedan delivery
- T—Limousine

*Except Models 46C, 49, 66C, 69, 56C and 76C.

INDEX

SUBJECT	PAGE	SUBJECT	PAGE
Battery.....	8	Kingpin.....	18
Belts, drive.....	7	Lamp bulbs.....	11
Body		Linings—clutch, brake.....	12, 16
General Body Information.....	19, 23	Lubrication.....	5, 6, 13, 14, 15
Height dimensions.....	20	Muffler.....	6
Length dimensions.....	21	Overdrive.....	13
Overall dimensions.....	1	Piston pins.....	3
Trunk opening dimensions.....	19	Pistons.....	2
Width dimensions.....	22	Propeller shaft.....	14
Types.....	23	Radiator, radiator hoses.....	7
Brakes		Rear axle.....	1, 15
Parking.....	16	Rims.....	15
Service.....	15, 16	Rings.....	3
Camber.....	18	Shock absorbers	
Camshaft.....	4	Front.....	17
Capacities		Rear.....	18
Cooling system.....	7	Spark plugs.....	9
Fuel tank.....	6	Springs	
Lubricants		Front.....	17
Crankcase.....	6	Rear.....	18
Overdrive.....	13	Valve.....	5
Transmissions.....	13, 14	Stabilizer	
Rear axle.....	15	Front.....	17
Carburetor.....	6	Rear.....	18
Caster.....	18	Starting motor.....	8
Choke, automatic.....	6	Steering.....	1, 17, 18
Circuit breakers.....	11	Suppression.....	9
Clutch (pedal operated).....	12	Suspension:	
Coil, ignition.....	9	Front.....	16, 17
Connecting rods.....	3	Rear.....	18
Cooling system.....	7	Switches.....	10
Crankshaft.....	3, 4	Tailpipe.....	6
Cylinders, cylinder head.....	2	Timing, engine.....	4, 5, 9
Distributor.....	9	Tires.....	1, 15
Electrical System.....	8, 9, 10, 11	Toe-in.....	18
Engine		Torque converter.....	14
Bore and stroke, displacement.....	1, 2	Torque, maximum.....	1, 2
Compression ratio.....	1, 2	Transmission	
Firing order, cylinder numbering.....	2, 9	Automatic.....	13, 14
General information.....	1, 2	Conventional.....	12, 13
Lubrication.....	5, 6	Conventional with overdrive.....	13
Type.....	1, 2	Ratios.....	12
Exhaust system.....	6	Types.....	1, 12, 13
Fan.....	7	Tread.....	1, 22
Frame.....	16	Turning diameter.....	1, 17
Fuel.....	6	Universal joints.....	14
Fuel pump.....	6	Valves, intake and exhaust.....	4, 5
Fuel system.....	6	Voltage regulator.....	8
Fuses.....	11	Water pump.....	7
Generator.....	8	Weight, shipping.....	1
Horns.....	10	Wheel alignment.....	18
Horsepower		Wheelbase.....	1, 21
Maximum brake.....	1, 2	Wheels.....	15
Taxable.....	2	Wheel spindle.....	18
Ignition system.....	9	Windshield wiper.....	10
Instruments.....	10		