

AMA Specifications – Passenger Car

The information contained herein is prepared, distributed by, and is solely the responsibility of the automobile manufacturing company to whose products it relates. Questions concerning these specifications should be directed to the manufacturer whose address is shown below. This uniform specification form was developed by the automobile manufacturing companies under the auspices of the Automobile Manufacturers Association.

MANUFACTURER <p style="text-align: center;">FORD MOTOR COMPANY</p>	CAR NAME <p style="text-align: center;">COMET</p>	
MAILING ADDRESS P. O. BOX 2053 DEARBORN, MICHIGAN	MODEL YEAR <p style="text-align: center;">1965</p>	ISSUED: 9-1-64 REVISED (*)

NOTES:

1. The Specifications herein are those in effect at date of compilation and are subject to change without notice by the manufacturer.
2. UNLESS OTHERWISE INDICATED:
 - a. Specifications apply to standard models without optional equipment. Significant deviations are noted.
 - b. Nominal design dimensions are used throughout these specifications.

TABLE OF CONTENTS

General Specifications 1	Drive Units 15	Rear Suspension 21	Body & Car - General 22
Engine - Mechanical 2	Brakes 18	Body Dimensions 22	Weights 33
Electrical 10	Front Suspension & Steering 19	Station Wagon 31	Index 37

BODY—TYPES AND STYLE NAMES—

Body type, number of passenger & style names; use manufacturer's code for series & body style.

<u>Body Model</u>	<u>Passenger</u>	<u>Model</u>	<u>Bucket Seat Model</u>
<u>Comet 202 Series</u>			
2-Door Sedan	6	62A	
4-Door Sedan	6	54A	
4-Door Station Wagon	6	71A	
<u>Comet 404 Series</u>			
2-Door Sedan	6-5	62B	62C (a)
4-Door Sedan	6		54B
4-Door Station Wagon	6		71B
4-Door Station Wagon (Villager)	6		71C
<u>Comet Caliente Series</u>			
4-Door Sedan	6	54D	
2-Door Hardtop	6-5	63D	63C (b)
2-Door Convertible	6-5	76D	76B (b)
<u>Comet Cyclone Series</u>			
2-Door Hardtop	5		63E (c)

- (a) Bucket seat option without console.
- (b) Bucket seat option with console.
- (c) Bucket seat with console - standard.

AMA Specifications — Passenger Car

MAKE OF CAR COMET MODEL YEAR 1965 DATE ISSUED 9-1-64 REVISED(*)

GENERAL SPECIFICATIONS

(All dimensions in Inches unless otherwise indicated)

MODEL	Additional Information Page No.:	54	62	63	76	71
Wheelbase (L101)	23			114		109.5
Tread	Front (W101)	22		55.0 - 55.6 (a)		
	Rear (W102)	22		56.0		
Maximum Overall Dimensions	Length (L103)	23		195.3		191.8
	Width (W103)	22		72.9		71.6
	Height (H101)	24	55.2	53.5	54.1	55.2
Transmission— (Specify trade name - opt., not available)	Manual	15		3-Speed - Standard 4-Speed - Optional (a)		
	Overdrive	16		Not Available		
	Automatic	16		Multi-Drive Merc-O-Matic - Optional		
Axle ratio	Manual	17		See Page 3-17		
	Overdrive	17		Not Available		
	Automatic	17		See Page 3-17		
Tire size	18		6.95 x 14			
Engine	Type, no. cyl., valve arr.	2	In Line, 6, OHV		90°V8, O.H.V.	
	Fuel system (Carb., other)	8	Carburetor			
	Bore and stroke	2	3.684x 3.13		4.005x 2.87	
	Piston displ., cu.in.	2	200		289-2V	289-4V
	Std. compression ratio	2	9.2:1		9.3:1	10.0:1
	Max. bhp at engine rpm	2	120 @ 4400		200 @ 4400	225 @ 4800
	Max. torque at rpm	2	190 @ 2400		282 @ 2400	305 @ 3200

(a) Models with V-8 Cyl. Engines

AMA Specifications—Passenger Car

MAKE OF CAR	COMET	MODEL YEAR	1965	DATE ISSUED	9-1-64	REVISED (*)	
				ALL MODELS			
MODEL			200		289-2V		289-4V

ENGINE—GENERAL

Type, no. cyls., valve arr.	In line 6, OHV		90°V8 O.H.V.
Bore and stroke (nominal)	3.684x 3.13		4.005x 2.87
Piston displacement, c.u. in.	200		289
Bore spacing (C/L to C/L)	4.08		4.38
No. system (front to rear)	L. Bank	5-6-7-8	
	R. Bank	1-2-3-4	
Firing order	1-5-3-6-2-4		1-5-4-2-6-3-7-8
Compras. ratio (nominal)	9.2:1 Nom		9.3:1-2-V 10.9-4V
Cylinder Head Material	Cast Iron		
Cylinder Block Material	Cast Iron		
Cylinder Sleeve-Wet, dry, none	None		
Number of mounting points	Front	Two	
	Rear	One	
Engine installation angle	4°-17'		
Taxable horsepower <small>Formula: $\frac{\text{Dia.}^2 \times \text{No. Cyl.}}{2.5}$</small>	32.5		51.2
Published max. bhp* @ eng. RPM	120 @ 4400	200 @ 4400	225 @ 4800
Published max. torque* (lb. ft. @ RPM)	190 @ 2400	282 @ 2400	305 @ 3200
Recommended fuel regular - premium	Regular		Regular Premium
Idle speed (spec. neutral or drive)	Manual	500-550 (Neutral)	
	Automatic	500-525 (Drive)	
		575-600 (Neutral)	475-500 (Drive)

ENGINE—PISTONS

Material	Aluminum Alloy		
Description and finish	Autothermic, Slipper Type, Tin Plated, and Cam Ground		
Weight (piston only) oz.	16.93		21.27
Clearance (limits)	Top land	.011-.014	
	Skirt	Top	.0023-.0029
		Bottom	.0008-.0014
Ring groove depth	No. 1 ring	.193-.200	
	No. 2 ring	.193-.200	
	No. 3 ring	.193-.200	
	No. 4 ring	.184-.191	

*Max. bhp (brake horsepower) and max. torque corrected to 60° F and 29.92 in. Hg atmospheric pressure.

AMA Specifications – Passenger Car

MAKE OF CAR COMET MODEL YEAR 1965 DATE ISSUED 9-1-64 REVISED(•) _____

POWER TEAMS

(Indicate whether standard or optional)

MODEL AVAILABILITY	ENGINE					TRANSMISSION	AXLE RATIO (Std. first)
	Displ. cu. in.	Carburetor	Compr. Ratio	BHP @ RPM	Torque @ RPM		
54-62-63	200	1V	9.2	120	190	Manual 3-Speed Automatic	3.20 - 3.50
				4400	2400		2.83 - 3.20
71-76	200	1V	9.2	120	190	Manual 3-Speed Automatic	3.20 - 3.50
				4400	2400		3.20
54-62-63-76	289	2V	9.3	200	282	Manual 3-Speed Manual 4-Speed Automatic	2.80 - 3.50
				4400	2400		2.80 - 3.50
							2.80 - 3.00
71	289	2V	9.3	200	282	Manual 3-Speed Manual 4-Speed Automatic	3.25 - 3.50
				4400	2400		3.25 - 3.50
							3.00
54-62-63-76	289	4V	10.9	225	305	Manual 3-Speed Manual 4-Speed Automatic	3.00 - 3.50
				4800	3200		3.00 - 3.50
							3.00
71	289	4V	10.9	225	305	Manual 3-Speed Manual 4-Speed Automatic	3.25 - 3.50
				4800	3200		3.25 - 3.50
							3.00

AMA Specifications – Passenger Car

MAKE OF CAR	COMET	MODEL YEAR	1965	DATE ISSUED	9-1-64	REVISED (a)
		ALL MODELS				
MODEL	200 CID	289-2V	289-4V			

ENGINE—RINGS

Function (top to bottom)	No. 1, oil or comp.			Compression
	No. 2, oil or comp.			Compression
	No. 3, oil or comp.			Oil
	No. 4, oil or comp.			---
Compression	Description - material, type, coating, etc.	#1 Cast Iron Alloy, Straight Face, Chrome Plated. #2 Cast Iron Alloy, Straight Face, Scraper Groove, Phosphate Coated		
	Width	.078	#1&2 .0774-.0781	
	Gap	.010-.020	.010-.020	
Oil	Description - material, type, coating, etc.	Multi-piece: Two rails and one spacer expander Rails - steel, chrome plated, oxide coated Spacer expander -blued steel		
	Width	.1875		
	Gap	.015-.055		
Expanders	Integral with oil ring assembly			

ENGINE—PISTON PINS

Material	Alloy steel heat treated - SAE 5015		
Length	3.030	3.020	
Diameter	.9120-.9123	.9119-.9124	
Type	Locked in rod, in piston, floating, etc.	Pressed fit in rod	
	Bushing	In rod or piston	none
		Material	---
Clearance	In piston	.0003-.0005	
	In rod	Press fit	
Direction & amount offset in piston	Right .0625		

ENGINE—CONNECTING RODS

Material	Forged Steel SAE-1041		
Weight (oz.)	18.65	19.97	
Length (center to center)	4.71-4.72	5.154-5.156	
Bearing	Material & Type	Unplated copper-lead alloy on steel back Replaceable inserts (a)	
	Overall length	.800-.810	.716-.726
	Clearance (limits)	.0008-.0023	.0009-.0029
	End play	.0035-.0105	.010-.020

(a) 289 C.I.D. Engine Copper-Lead Alloy.

AMA Specifications—Passenger Car

MAKE OF CAR	COMET	MODEL YEAR	1965
		DATE ISSUED	9-1-64
		REVISED (*)	ALL MODELS
MODEL	200 CID		289 CID

ENGINE—CRANKSHAFT

Material		Precision molded, alloy cast iron		
Vibration damper type		Rubber floated		
End thrust taken by bearing (No.)		3		
Crankshaft end play		.004 - .008		
Main bearing	Material & type		Copper-lead alloy on steel back, replaceable inserts	
	Clearance		.0008 - .0026	
	Journal dia. and bearing overall length	No. 1	2.248 x 1.015	2.248 x .885
		No. 2	2.248 x 1.015	2.248 x .885
		No. 3	2.248 x 1.015	2.248 x 1.132
		No. 4	2.248 x 1.015	2.248 x .885
		No. 5	2.248 x 1.270	2.248 x .885
		No. 6	2.248 x 1.015	
No. 7		2.248 x 1.015		
Dir. & amt. cyl. offset		None	Right bank leads .84	
Crankpin journal diameter		2.123		

ENGINE—CAMSHAFT

Location		In block	
Material		Special alloy iron, precision molded, induction hardened, phosphate coated	
Bearings	Material	Steel backed babbitt	
	Number	4	5
Gear or chain		Chain	
Crankshaft gear or sprocket material		Sintered iron or steel	
Camshaft gear or sprocket material		Cast iron	
Type of Drive	Timing chain	No. of links	50
		Width	.875 max.
		Pitch	.375

ENGINE—VALVE SYSTEM

Hydraulic lifters (Std, opt, NA)		Standard	
Valve rotator, type (intake, exhaust)		Ford free turn (intake and exhaust)	None
Rocker ratio		1.50:1	1.60:1
Operating tappet clearance (indicate hot or cold)	Intake	Zero	
	Exhaust	Zero	
Timing marks on flywheel, damper, other		Timing pointer on cover, marks on crankshaft damper	

(Continued)

AMA Specifications—Passenger Car

MAKE OF CAR COMET MODEL YEAR 1965 DATE ISSUED 9-1-64 REVISED(*)
 MODEL 200 CID / ALL MODELS 289 CID

ENGINE—VALVE SYSTEM (cont.)

Timing	Intake	Opens (°BTC)	6	20	
		Closes (°ABC)	54	66	
		Duration - deg.	240	266	
	Exhaust	Opens (°BBC)	39	56	
		Closes (°ATC)	21	20	
		Duration - deg.	240	256	
Valve opening overlap		27°	40°		
Intake	Material		Aluminized steel - SAE 1047		
	Overall length		4.26	4.86	
	Actual overall head dia.		1.527	1.78	
	Angle of seat & face		45°		
	Seat insert material		None		
	Stem diameter		.310	.3420	
	Stem to guide clearance		.0008 - .0025	.0010 - .0027	
	Lift (@ zero lash)		.348	.368	
	Outer spring press. and length	Valve closed (lb. @ in.)	54 @ 1.59	71 - 79 @ 1.78	
		Valve open (lb. @ in.)	150 @ 1.22	161 - 177 @ 1.39	
	Inner spring press. and length	Valve closed (lb. @ in.)	--		
		Valve open (lb. @ in.)	--		
	Exhaust	Material		Cast austenitic steel, aluminized	
		Overall length		4.26	4.86
Actual overall head dia.		1.266	1.450		
Angle of seat & face		45°			
Seat insert material		None			
Stem diameter		.309	.341		
Stem to guide clearance		.0018 - .0035	.0020 - .0037		
Lift (@ zero lash)		.348	.380		
Outer spring press. and length		Valve closed (lb. @ in.)	54 @ 1.59	71 - 79 @ 1.78	
		Valve open (lb. @ in.)	150 @ 1.22	161 - 177 @ 1.39	
Inner spring press. and length		Valve closed (lb. @ in.)	--		
		Valve open (lb. @ in.)	--		

ENGINE—LUBRICATION SYSTEM

Type of lubrication (splash, pressure, nozzle)	Main bearings	Pressure
	Connecting rods	Pressure
	Piston pins	Oil Mist
	Camshaft bearings	Pressure
	Tappets	Pressure
	Timing gear or chain	Splash
	Cylinder walls	Pressure Stream

(Continued)

AMA Specifications – Passenger Car

MAKE OF CAR COMET MODEL YEAR 1965 DATE ISSUED 9-1-64 REVISED (*)

MODEL 200 CID ALL MODELS 289 CID

ENGINE—LUBRICATION SYSTEM (cont.)

Oil pump type	Gerotor	Rotor
Normal oil pressure (lb. @ engine rpm)	45 - 55 @ 2000	50 - 60 @ 2000
Oil pressure sending unit (elect. or mech.)	Electric	
Type oil intake (floating, stationary)	Stationary shrouded screen in sump	
Oil filter system (full flow, partial, other)	Full flow	
Filter replacement (element, complete)	Complete	
Capacity of crankcase, less filter-refill (qt.)	3.5 4.5 with filter	4 5 with filter
Oil grade recommended (SAE viscosity and temperature range)	90° F and above - SAE 30 or 10W-30 20° F to 90° F - SAE 20 or 20W or 10W-30 -10° F to 20° F - SAE 5W-20 or 10W or 10W-30 -10° F and below - SAE 5W-20	
Engine Service Requirement (MM, MS, etc.)	MS	

ENGINE—EXHAUST SYSTEM

Type (single, single with cross-over, dual, other)	Single	Single Y
Muffler No. & type (reverse flow, straight thru, separate resonator)	One, reverse flow (a)	
Exhaust pipe dia. (O.D.) wall thickness	Branch	2.00 .075
	Main	2.00 .075
Tail pipe diameter (O.D. & wall thickness)	1.50 .060	2.00 .062

ENGINE—CRANKCASE VENTILATION SYSTEM

Type (ventilates to atmos., induction system, other)	Standard	Road Draft Tube
	Optional	Induction System (b)(c)
Control unit	Make and model	
	Location	
	Energy source (manifold vacuum, carburetor air stream, other)	
Complete system	Control method (variable orifice, fixed orifice, other)	
	Discharges (to intake manifold, carb. air intake, air cleaner intake, other)	To atmosphere
	Air inlet (breather cap, carburetor air cleaner, other)	Breather cap
	Flame arrestor (screen, check valve, other)	Screen

- (a) One, reverse flow muffler and resonator used on 289 4V premium fuel models.
- (b) Variable orifice valve with air inlet through breather cap is standard in New York and optional in all other States except California.
- (c) Variable orifice valve with inlet from air cleaner through breather cap is standard in California.

AMA Specifications— Passenger Car

MAKE OF CAR COMET MODEL YEAR 1965 DATE ISSUED 9-1-64 REVISED ^(*)
ALL MODELS

MODEL 200 CID 289 CID

ENGINE—FUEL SYSTEM

(See Supplement to Page 8 for Details of Fuel Injection, Supercharger, etc. if used)

Induction type: Carburetor, fuel injection, supercharger.		Carburetor
Fuel tank	Capacity (gals.)	20
	Filler location	Rear; Side on Station Wagon Models
Fuel pump	Type (elec. or mech.)	Mechanical
	Locations	Left Side of Engine
	Pressure range	4 - 5 psi 4.5 - 5.5 psi
Vacuum booster (std., optional, none)		None
Fuel filter	Type	#1 Accreted Paper (Disposable) #2 Wire Cloth, Plastic (Perm.)
	Locations	#1 Integral with Fuel Pump #2 In Fuel Tank
Carburetor	Choke type	Automatic
	Intake manifold heat control (exhaust or water)	Exhaust Heated Manifold, Water Heated Carb. Spacer Exhaust Heated Manifold
	Air chr. type	Standard: Dry, Replaceable Element (a) Optional: None

CARBURETOR SUPPLEMENTARY INFORMATION

Model Usage	Engine Displ.	Transmission	Carburetors		No. Used and Type	Barrel Size
			Make	Model		
<u>Emission</u>						
11	200	Manual	Ford - GPD	C50F-9510-E	One-1V Downdraft	1.437
11	200	Automatic	Ford - GPD	C50F-9510-F		
<u>Non-Emission</u>						
11	200	Manual	Ford - GPD	C50F-9510-N	One-1V Downdraft	1.437
11	200	Automatic	Ford - GPD	C50F-9510-R		
<u>Emission</u>						
11	289	Manual	Ford - GPD	C5ZF-9510-A	One-2V	1.437
11	289	Automatic	Ford - GPD	C5ZF-9510-B	One-2V	1.437
11	289	Manual	Ford - GPD	C5ZF-9510-C	One-4V	1.437
11	289	Automatic	Ford - GPD	C5ZF-9510-D	One-4V	1.437
<u>Non-Emission</u>						
11	289	Manual	Ford - GPD	C5ZF-9510-G	One-2V	1.437
11	289	Automatic	Ford - GPD	C5ZF-9510-H	One-2V	
11	289	Manual	Ford - GPD	C5ZF-9510-J	One-4V	1.08 Primary
11	289	Automatic	Ford - GPD	C5ZF-9510-K	One-4V	1.19 Secondary

a) Thermostatically controlled carb. air temperature with 289 CID engine.

AMA Specifications - Passenger Car

MAKE OF CAR COMET MODEL YEAR 1965 DATE ISSUED 9-1-64 REVISED (*)
 ALL MODELS
 MODEL: 200 CID 289 CID

ENGINE-COOLING SYSTEM

Type system (pressure, pressure vented, atmospheric, other)		Pressure		
Radiator cap relief valve pressure		12 - 15 psi		
Circulation thermostat	Type (choke, bypass)	Choke, poppet valve		
	Starts to open at (°F)	185 - 192	192 - 199	
Water pump	Type (centrifugal, other)	Centrifugal		
	GPM @ 1000 pump rpm	9	18	
	Number of pumps	One		
	Drive (V-belt, other)	V-Belt		
	Bearing type	Double row, sealed ball		
By-pass recirculation type (internal, external)		Internal	External	
Radiator core type (cellular, tube and fin, other)		Downflow, cellular, tubular		
Cooling system capacity	With heater (qt.)	9.5	15	
	Without heater (qt.)	8.5	14	
	Opt. equipment-specify (qt.)	None		
Water jackets full length of cylinder (yes, no)		Yes	No	
Water all around cylinder (yes, no)		Yes		
Radiator hose	Lower	Number and type (molded, straight)	One, molded	
		Inside diameter	1.25 1.75	
	Upper	Number and type (molded, straight)	One, molded	
		Inside diameter	1.25 1.50	
	By-pass	Number and type (molded, straight)	None	One, molded
		Inside diameter	--	.615
Fan	Number of blades & Spacing		4, uneven 6, uneven (a)(b) 4, uneven 5, uneven (a)	
	Diameter		14-1/2 15 (a) (b) 17	
	Ratio-fan to crankshaft rev.		1.18:1 (c) 1.04:1 (b) 1.05:1 1.13:1 (a)	
	Fan cutout type		None Thermo - Modulated (a)	
	Bearing type		Double row, sealed ball	
* Drive belts (indicate belt used by letter)	Fan	A B C D	H J	
	Generator	A B C D	H J	
	Water Pump	A B C D	H J	
	Power Steering	C		I
	Air Conditioning	D		K
	Crankshaft	A B C D	H I J K	
Idler		K		

* Drive Belt Dimensions	A	B	C	D(Dual)	H	I	J(Dual)	K
Angle of V	36°				36°			
Nominal length (SAE)	33.5	33.25	44.5	47.5	49.5	39.5	49.25	56.5
Width	15/32				15/32	1/2	15/32	1/2

- (a) Standard with air conditioning
- (b) Standard with power steering

AMA Specifications – Passenger Car

MAKE OF CAR COMET MODEL YEAR 1965 DATE ISSUED 9-1-64 REVISED(*)
 ALL MODELS
 MODEL 200 CID 289 CID

ELECTRICAL—SUPPLY SYSTEM

Battery	Make and Model	Autolite C5AF-10655-A C5AF-10655-B (a)		
	Voltage Rtg. & Total Plates	12 volts	54 plates 66 plates (a)	
	SAE Designation & Amp Hr. Rtg	45 amp	55 amp (a)	
	Location	Engine compartment, right side		
	Terminal grounded	Negative		
Alternator Generator	Make	Ford		
	Model	C5DF-10300-A 38 AMP		
	Type	3 Phase		
	Ratio—Gen. to Cr/s rev.	2.3:1 on 6 cyl. 2.5:1 8 cyl.		
Alt.	Gen. cut-in (hot)—engine rpm	370 @ 12.8 volts		
Regulator	Make	Ford		
	Model	C5AF-10316-A		
	Type	2 coil		
	Cutout relay	Closing voltage @ generator rpm	Not applicable	
		Reverse current to open	Not applicable	
	Regu- lated	Voltage	14.1 - 14.7 at 75°F	
		Current	5 Amps.	
	Voltage test con- ditions	Temperature	75°F	
Load		None		
Other		None		

ELECTRICAL—STARTING SYSTEM

Starting motor	Make	Ford			
	Model	C4DF-11001-B	C4OF-11001-B	C4OF-11001-A	
	Rotation (drive end view)	Clockwise			
	Engine cranking speed	240 RPM @ 70°F	180 RPM @ 80°F		
	Test conditions	70°F	80°F		
	Lock test	Amps	54.0	67.0	
		Volts	4.2	6.0	
		Torque (lb. ft.)	14.0	15.5	
	No load test	Amps	50	70	
		Volts	12		
RPM (min.)		9500			
Motor control	Switch (solenoid, manual)	Solenoid			
	Starting procedure				

(a) HD option.

(Continued)

AMA Specifications – Passenger Car

MAKE OF CAR COMET MODEL YEAR 1965 DATE ISSUED 9-1-64 REVISED (*)

MODEL _____

ELECTRICAL—STARTING SYSTEM (cont.)

Motor Drive	Engagement type		Positive - Electro-mechanical	
	Pinion meshes (front, rear)		Front	
	Number of teeth	Pinion	9	
		Flywheel	132	160 on V-8
Flywheel tooth face width		.365		

ELECTRICAL—IGNITION SYSTEM 200 CID Six cylinder

Coil	Make		Ford			
	Model		FAC - 12029-C			
	Amps	Engine stopped	4.5			
Engine idling		2.5				
Distributor	Make		Ford			
	Model		C5DF-12127-E	C5AF-12127-F (w/auto. trans.)		
	Cent'fgal adv. in crankshaft degrees @ engine rpm (nominal)	Start (rpm)				
		Intermediate points deg. @ rpm	None			
		Max deg. @ rpm	(With automatic trans.)			
	Vacuum adv. in crankshaft degrees @ in. Hg. (nominal)	Start (in Hg)	0° @ .2"		25.5° @ 6.8" (PT) 0-1° @ .3" (WOT)	
		Intermediate points, deg @ in Hg	PT	WOT	PT	WOT
			29° @ 6.8"	0° @ .44"	25.8° @ 8.0"	8° @ 1.3"
	Max. deg. in. Hg.	27° @ 7.0"	15° @ 1.3"	24.5° @ 7.0"	15.5° @ 3.0"	
		29.5° @ 8.0"	22° @ 3.8"	27° @ 6.8"	19.5° @ 3.8"	
Breaker gap (in.)		.024 - .026				
Cam angle (deg.)		35° - 38°				
Breaker arm tension (oz.)		17 - 20				
Timing	Crankshaft deg. @ rpm.		6° (12° w/automatic transmission)			
	Mark location		Indicator scale on cover			
	Cylinder numbering system (see page 2)		Front to rear 1-2-3-4-5-6			
	Firing order (see page 2)		1-5-3-6-2-4			
Spark Plug	Make and model		Autolite BF-82			
	Thread (mm)		18			
	Tightening torque (lb. ft.)		15 - 20			
	Gap		.032 - .036			
Cable	Conductor type		Resistance core cable			
	Insulation type		Neoprene Sheath			
	Spark plug protector		Neoprene Boot			

ELECTRICAL—SUPPRESSION

Locations & type	Capacitor at the alternator and voltage regulator, wheel static collectors in front wheel. Resistance core ignition cables.
------------------	---

NOTE: All distributor initial settings must be made with the distributor vacuum line disconnected.

AMA SPECIFICATIONS - PASSENGER CAR

Page 11-A
9-1-64

1965 COMET

		289 CID 2V Manual Trans.	289 CID 2V Automatic Trans.	289 CID 4V
<u>Distributor</u>	Make	Ford	Ford	Ford
	Model	C5AF-12127-M	C5AF-12127-N	C5GF-12127-A
Centri. Adv. Start (RPM)		0-1° @ 1100	0-1°@750 14.5°@1320	0-1° @ 960
Intermediate Pts. Deg. @ RPM		14-16 @ 1800 24.5-27.5 @ 4000	22.5° @ 4000	12-14 @ 1500 17-20 @ 4000
Max. Deg @ RPM		27.5 @ 4000	24° @ 4000	20° @ 4000
Vacuum Adv. @ In. Hg.				
Start		0-1° @ 6"	0-1° @ 7"	0-1° @ 6"
Intermediate Hg.		10° @ 10" 18° @ 15"	13° @ 10" 20.5° @ 14"	10° @ 10" 18° @ 10"
Maximum		22° @ 17"	24° @ 4000	22° @ 17"
Breaker Gap (In.)			.014 - .016	
Cam Angle (Deg.)			26 - 28.5	
Breaker Arm Tension			17 - 20 oz.	
Timing: Crankshaft Deg.			6°	
Mark Location			Pointer on front cover	
Cylinder Numbering System		Front to rear	R-1-2-3-4 L-5-6-7-8	
Firing Order			1-5-4-2-6-3-7-8	
Spark Plug		Autolite	BF-42	
Thread (mm)			18	
Tightening Torque (lb.ft.)			15 - 20	
Gap			.032 - .036	
Cable	Conductor Type		Resistance core cable	
	Insulation Type		Neoprene sheath	
	Spark plug Protector		Neoprene boot	

AMA Specifications – Passenger Car

MAKE OF CAR	COMET	MODEL YEAR	1965	DATE ISSUED	9-1-64	REVISED (*)
		ALL MODELS				
MODEL	200 CID		289 CID			

ELECTRICAL—LAMP BULBS

Give quantity used and trade number, e.g., Headlamp 2-5400 S, dual headlight 2-4001, 2-4002.

Headlamps & arrangement	Two # 4001 (Inboard)	Two # 4002 (Outboard)	Horizontal
Headlamp beam indicator	One # 1895		
Parking	Two # 1157		
Tail	Two # 1157		
Stop	Two # 1157 Same as tail		
Direction signal	Front	Two # 1157 Same as parking	
	Rear	Two # 1157 Same as stop	
	Indicator	Two # 1895	
License Plate	One # 1155		
Oil pressure indicator	Same as inst.		
Charge indicator	" " "		
Instrument	Four # 1895		
Clock	One # 1895		
Radio	One # 1891		

Indicate also whether the following lamp assemblies are standard equipment, optional, or NA.

Ignition lock	NA
Back up	Optional Two # 1156
Dome	Standard One # 1003
Glove compartment	Optional One # 1895
Prkg. brake signal	NA
Luggage compartment	Optional One # 631
Underhood	NA
Courtesy	Standard & Optional One # 1155 for panel mount & 2 # 1155 for door mount
Map	NA
Tachometer	One # 1895 (A) (B)
Vacuum Gage	One # 1895 (A) (B)
Ash Tray	Optional One # 1145
Clock	One # 1895 (A) (B)

- (A) Standard on Cyclone series
- (B) Optional on all except Cyclone series

AMA Specifications – Passenger Car

MAKE OF CAR COMET MODEL YEAR 1965 DATE ISSUED 9-1-64 REVISED (a)

ALL MODELS

MODEL 200 CID 289 CID

ELECTRICAL—FUSE & CIRCUIT BREAKER DATA

Use trade number of fuse, e.g., SFE-10. Indicate circuit breaker by ampere capacity suffixed by letters "C.B.", e.g., 30 C.B. Where fuse or circuit breaker protects multiple circuits indicate first use by a letter and repeat the same letter for all units protected by the same fuse or circuit breaker, e.g., Parking lamp SFE-10 (a), Direction indicator same as (a).

Headlamp	18 CB (a)	
Headlamp beam indicator	Same as (a)	
Parking lamp	3 AG-15 (b) or AGC-15	
Tail lamp	Same as (b)	
Stop lamp	Same as (b)	
Direction indicator		
License plate lamp	Same as (b)	
Instrument lamp	1AG-2.5 (d) or AGA-2.5	Main Fuse 3AG-15 (b)
Ignition lamp	None	
Back up lamp	Same as (c)	
Dome lamp	Same as (b)	
Clock	None	
Clock lamp	None	
Radio	SFE-7.5	
Glove compartment lamp	Same as (b)	
Trans. selector lamp	Same as (d)	
Radio Lamp	Same as (d)	
Heater Blower	SFE-14	
Air Conditioning	3AG-15	
Power Tail Gate	30 CB	
Convertible Top	30 CB	
Cigar Lighter		
Windshield Wiper	5 CB	Optional 2-Speed 12 CB
Tachometer	Same as (d)	Cyclone Series
Vacuum Gage	Same as (d)	Cyclone Series

ELECTRICAL—LOCATION OF OUTSIDE LAMPS

		Lowest	22.9	
		Tail	Highest	22.9
Height above ground to center of bulb	Stop		22.9	
	Backup			
	License, rear			
	Directional	Front		16
		Rear		22.9
	Headlamp	Low		24.7
		High		31.3
	Distance from C/L of car to center of bulb	Tail	Inside	-
			Outside	28
		Stop		28
Backup				
License, rear			Centerline	
Directional		Front		30.2
		Rear		
Headlamp		Inside		29.6
	Outside*		30.0	

* If single headlamps are used enter here.

AMA Specifications – Passenger Car

MAKE OF CAR COMET MODEL YEAR 1965 DATE ISSUED 9-1-64 REVISED (•)
ALL MODELS

MODEL 200 CID 289 CID

DRIVE UNITS—CLUTCH (Manual Transmission)

Make & type		Long Manufacturing, Non-centrifugal, single disc, dry plate (a) Long Manufacturing, Semi-centrifugal, single disc, dry plate (b)	
Type pressure plate springs		Coil	
Effective plate pressure (lb.)		1305	1269
No. of clutch driven discs		One	
Clutch facing	Material	Woven asbestos	
	Outside & inside dia.	8.50 x 5.375	10.40 x 6.50
	Total eff. area (sq.in.)	68.1	103.7
	Thickness	.125	
	Engagement cushioning method	Torbend disc	
Release bearing	Type & method of lubrication	Ball thrust, prepack, sealed	
Torsional damping	Methods: springs, friction material	Springs	

DRIVE UNITS—TRANSMISSIONS

Manual (std. or opt.)	Standard
Manual with overdrive (std. or opt.)	Not available
Automatic (std. or opt.)	Optional

DRIVE UNITS—MANUAL TRANSMISSION

Number of forward speeds		Three	Three	Four	Alt. Ratios
Transmission ratios	In first	2.76	2.79:1	2.74:1	2.78:1
	In second	1.63	1.70:1	2.04:1	1.94:1
	In third	1.00:1	1.00:1	1.51:1	1.36:1
	In fourth	None	None	1.00:1	1.00
	In reverse	3.74	2.87:1	2.81:1	2.78:1
Synchronous meshing, specify gears		2nd-3rd	1st-2nd-3rd	1st-2nd-3rd-4th	
Shift lever location		Column		Floor	
Lubricant	Capacity (pt.)	2.5	3.5		
	Type recommended	Mild, Extreme Pressure M-568-D			
	SAE viscosity number	Summer	SAE 80		
		Winter	SAE 80		
Extreme cold		SAE 80			

- (a) Models with 200 CID 6 cylinder engine.
- (b) Models with 289 CID engines.

AMA Specifications – Passenger Car

MAKE OF CAR	COMET	MODEL YEAR	1965
		DATE ISSUED	9-1-64
		ALL MODELS	
MODEL	200 CID	289 CID	

DRIVE UNITS—PROPELLER SHAFT (cont.)

Inter-mediate bearing	Type (plain, anti-friction)	None
	Lubrication (fitting, prepack)	None
Universal joints	Make	Ford
	Number used	Two
	Type (ball and trunnion, cross, other)	Cross
	Bearing	Type (plain, anti-friction)
Lubric. (fitting, prepack)		Prepack
Drive taken through (torque tube or arms, springs)		Springs
Torque taken through (torque tube or arms, springs)		Springs

DRIVE UNITS—REAR AXLE

Description (see Instructions)	Conventional, semi-floating, overhund hypoid pinion (6 Cyl.) Conventional, semi-floating, straddle mounted hypoid pinion (8 Cyl.)			
Limited Slip differential, type	None			
Drive Pinion Offset	1.5			
No. of differential pinions	Two			
Gear ratios (Std. equip.)	Manual transmission	3.20:1	3.00:1 3.25:1 (a)	
	Overdrive transmission	Not Available		
	Automatic transmission	2.83:1 3.20:1 (a)	3.00:1 2.80:1 (c)	
Ring gear O.D. (std. ratio)	7.25	8.00	7.75 (b)	
Pinion adjustment (shim, other)	Shims			
Pinion bearing adj. (shim, other)	Collapsible spacer			
Wheel bearing type	Single row, double sealed ball bearing			
Lubricant	Capacity (pt.)	2.5	4.5	
	Type recommended	Hypoid extreme pressure		
	SAE viscosity number	Summer	SAE 90	
		Winter	SAE 90	
Extreme cold		SAE 80		

REAR AXLE RATIO TOOTH COMBINATIONS

(See page 3 for axle ratio usage)

Axle ratio		2.80	2.83	3.00	3.20	3.25
No. of teeth	Pinion	15	12	13	10	12
	Ring gear	42	34	39	32	39

- (a) Model 76 and 71.
- (b) Models with 2.80:1 axle.
- (c) 289 CID 2V - Models 54, 62, 63 and 76.

AMA Specifications – Passenger Car

MAKE OF CAR	COMET	MODEL YEAR	1965	DATE ISSUED	9-1-64	REVISED (*)
		ALL MODELS				
MODEL	200 CID		289 CID			

DRIVE UNITS—WHEELS

Type & material		Stamped steel disc	
Rim (size and flange type)	Std.	14 x 4.5J	14 x 5.0J
	Opt.	14 x 5.0J	None
Attachment	Type (bolt or stud)	Stud	
	Circle diameter	4.5	
	Number and size	Four 1/2-20	Five 1/2-20

DRIVE UNITS—TIRES

Standard (List option below)	Size & ply	6.95 x 14 2 ply (4 ply rating) (a)	
	Type - Nylon, etc.	Rayon tubeless	
Rev/mile at 50 mph.		(b)	(c)
Inflation press. (cold)	Front	24	
	Rear	24	28 Station Wagon
Optional tires - size and ply		N. A.	7.35 x 14 2 ply (4 ply rating)

BRAKES—SERVICE

Type (duo-servo, disc, balanced, etc.)		Duo-servo	
Self adjusting (std., opt., N.A.)		Standard	
Hydraulic system type (single, dual, etc.)		Single	
Power brake make & type (remote, integral, etc.)		Integral (c)	
Effective area (sq. in.)*		107.0	129.8 (d) 126.0
Gross lining area (sq. in.)**		128.8	154.6 (d) 152.8
Swept drum area (sq. in.)***		212.0	254.0 (d) 251.3
Percent brake effectiveness—front		61.4	57.9 (d) 60.6 59.0 (d)
Drum	Diameter	Front	9.0 10.0
		Rear	9.0 10.0
Type and material		Composite, pressed steel disc and cast iron drum (e)	
Wheel cylinder bore	Front	1.062 1.125	
	Rear	.844 .906 (d)	.906 .938 (d)
Master cylinder bore		1.0	
Available pedal travel		6.5	4.75 Power
Line pressure at 100 lb. pedal load		702 750	
Shoe clearance adjustment		.015	

(Continued)

* Excludes rivet holes, grooves, chamfers, etc.
 ** Includes rivet holes, grooves, chamfers, etc.

*** Total swept areas for four brakes:

Widest lining contact width for each brake x its drum circumference.

- (a) Model 76 with 289 CID and air conditioning uses 7.35 x 14.
- (b) 6.95 x 14 - 821.
- (c) 7.35 x 14 - 794.
- (d) Model 76 and 71.
- (e) Models with 289 CID engines: Front - Full cast drum.

AMA Specifications—Passenger Car

MAKE OF CAR	COMET	MODEL YEAR	1965
		DATE ISSUED	9-1-64
		REVISED(*)	
		ALL MODELS	
MODEL	200 CID	289 CID	

BRAKES—SERVICE (cont.)

Brake lining	Bonded or riveted		Riveted		
	Front Shoe	Material	Molded asbestos		
		Size (length x width x thickness)	Front wheel	7.65 x 2.25 x .214	8.35 x 2.25 x .244
			Rear wheel	7.65 x 1.50 x .214	
				7.65 x 2.25 x .214 (a)	8.35 x 1.75 x .244
	Segments per shoe		One		
	Rear Shoe	Material	Molded asbestos		
		Size (length x width x thickness)	Front wheel	10.00 x 2.25 x .269	10.75 x 2.25 x .269
			Rear wheel	10.00 x 1.50 x .269	
				10.00 x 2.25 x .269 (a)	10.75 x 1.75 x .269
Segments per shoe		One			

BRAKES—PARKING

Type of control	Hand operated with twist release	
Location of control	Left of steering column	
Operates on	Rear service brakes	
If separate from service brakes	Type (internal or external)	None
	Drum diameter	None
	Lining size (length x width x thickness)	None

FRAME or UNITIZED CONSTRUCTION

Type and description	Unitized construction with reinforced side rails, crossmembers, and rocker panels.
----------------------	--

SUSPENSION—GENERAL (See Supplemental page 19 for details on Air Suspension)*

Provision for car leveling	None	
Provision for brake dip control	Anti-dive front suspension	
Provision for acc. squat control	Asymmetrical type rear spring mounting	
Special provisions for car jacking	None	
Shock absorber front & rear	Type	Direct acting, rebound cut off
	Make	Ford and Gabriel
	Piston dia.	1.0
Other special features		

SUSPENSION—FRONT

Type and description	Independent S. L. A. suspension with ball joints and coil springs.
----------------------	--

* Air Suspension:
 Air spring type
 Compressor data
 type
 make
 drive ratio
 Normal operating pressures
 spring rates
 leveling data

(Continued)

(a) Model 76 and 71.

AMA Specifications – Passenger Cars

MAKE OF CAR COMET MODEL YEAR 1965 DATE ISSUED 9-1-64 REVISED (a)
ALL MODELS
 MODEL 200 CID 289 CID

SUSPENSION FRONT (cont.)

Spring	Type	Coil			
	Material	Steel SAE 5160			
	Size (coil design height & I.D.; bar length x dia.)	8.62, 3.87, 119 x .56			
	Spring rate (lb. per in.)	220/200	245/225 (a)	245/225	280/260 (a)
	Rate at wheel (lb. per in.)				
	Design load (lb. @ design height)	1250/1220	1475/1415 (b)	1475/1415	1635/1565 (b)
Stabilizer	Type (link, linkless, frameless)	Link			
	Material & bar diameter	SAE 1090 .62 Dia. .69 Dia. (c)			

STEERING

Manual (std., opt., NA)		Standard				
Power (std., opt., NA)		Optional				
Adjustable steering wheel (tilt, swing, other)	Type and description	None				
	(std., opt., NA)	NA				
Wheel diameter	Manual	16.0				
	Power	16.0				
Turning diameter	Outside front	Wall to wall (l. & r.)	43.3'	41.8' (c)	43.5'	42.2' (c)
		Curb to curb (l. & r.)	40.9'	39.4' (c)	41.2'	39.8' (c)
	Inside rear	Wall to wall (l. & r.)	24.5'	23.2' (c)	24.9'	23.6' (c)
		Curb to curb (l. & r.)	25.1'	23.8' (c)	25.5'	24.2' (c)
Outside wheel angle with inside wheel at 20°		18° 31'		18° 50'		

Manual	Gear	Type	Recirculating ball and nut				
		Make	Ford				
		Ratios	Gear	19.88:1			
			Overall	27:1			
	No. wheel turns		4.6				
Power	Type (coaxial, linkage, etc.)		Linkage				
	Make						
	Gear	Type	Recirculating ball and nut				
		Ratios	Gear	16:1			
			Overall	21.6:1			
	Pump driven by		Belt off crankshaft pulley				
	Number wheel turns		3.5				
Linkage	Type		Parallelogram with cross link and idler arm				
	Location (front or rear of wheels, other)		Rear				
	Drag link (trans. or longit.)		Transverse				
	Tie rods (one or two)		Two				

(a) Model 76. Model 71 220/200 - (Continued)
 (b) Model 76. Model 71 1280/1220 - 200 CID; 1405/1345 - 289 CID
 (c) Model 71.

AMA Specifications – Passenger Car

MAKE OF CAR COMET MODEL YEAR 1965 DATE ISSUED 9-1-64 REVISED (*)

MODEL 200 CID 289 CID

STEERING (cont.)

Steering Axis	Inclination at camber (deg.)		7°19' @ 45' camber
	Bearings (type)	Upper	Joint with sintered iron ball and Teflon coated fabric washer
		Lower	Joint with sintered iron ball
	Thrust		Steel spring and cap in all joints
Wheel alignment (range and preferred)	Caster (deg.)		0° to 1° 0° 30' Preferred
	Camber (deg.)		0° to 1° 0° 30' Preferred
	Toe-in (outside tread-inches)		5/16 Max. 1/4 Min. 9/32 Preferred
Steering spindle & joint type			Integral assembly with ball socket joints
Wheel spindle	Diameter	Inner bearing	1.75 I. D.
		Outer bearing	.75 I. D.
	Thread size		3/4 - 16 NF3
	Bearing type		Tapered roller

SUSPENSION—REAR

Type and description			Hotchkiss drive	
Drive and torq. taken through (see page 17)			Rear spring	
Spring	Type		Semi-elliptic	
	Material		Spring steel SAE 5160	
	Size (length x width, coil design height and I.D.; bar length & dia.)		55 x 2.5	
	Spring rate (lb. per in.)		72 82 (a) 112 (b)	
	Rate at wheel (lb. per in.)		77 89 (a) 119 (b)	
	Design load (lb. at design height)		710	
	Mounting insulation type		Silent bloc, rubber bushing	
	If leaf	No. of leaves		4
		Inserts	Type and size	Tip - 2.50 x 2.18 x .09 thick
			Material	Graphite impregnated polyethylene
Shackle (comp. or tens.)		Compression		
Stabilizer	Type (link, linkless, frameless)		None	
	Material		--	
Track bar type			None	

- (a) Model 76.
(b) Model 71.

AMA Specifications – Passenger Car

MAKE OF CAR COMET MODEL YEAR 1965 DATE ISSUED 9-1-64 REVISED (*)

CAR AND BODY DIMENSIONS—GENERAL

Dimensions herein are those adopted by the Society of Automotive Engineers. Brief descriptions of these dimensions are listed on pages 34-36. Complete definitions are listed in section E-1 of the SAE Aeronautical - Automotive Drawing Standards. The dimensions are developed from the following basic points:

1. Body dimensions are for all body styles.
2. All interior dimensions are taken with manikin 15.0 inches outboard of car centerline unless otherwise stated.
3. All interior dimensions are measured with the front seat in the lowest and rearmost position.
4. Unless otherwise specified, all exterior height dimensions are taken with a full design load which consists of 5 passengers, 300 lbs. front, 450 lbs. rear; includes spare wheel, tire and tools, and full complement of gas, oil, water and tires to recommended pressure, etc.
5. The SAE manikin with 90th percentile leg length will be used for recording purposes.
6. The H Point is the pivot center of the manikin's torso and thigh.
7. The D Point is the point of tangency of a horizontal line and the lowest point of the manikin.
8. The Torso Line is a line parallel to the small of manikin's back and extending through the H Point.

EXTERIOR WIDTH DIMENSIONS

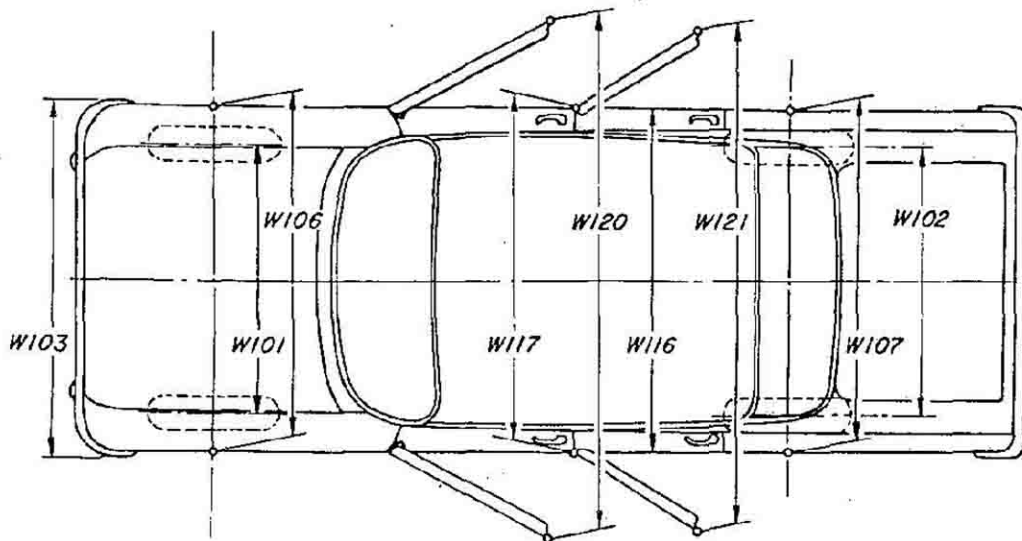

MODEL	Ref. No.	62	54	63	76	71
Tread - front	W101	55.0	55.6 (a)			
Tread - rear	W102	56.0				
Maximum overall car width	W103	72.9				71.6
Maximum overall body width	W116	69.7				
Maximum body width at #2 pillar	W117	69.4				
Front fender overall width	W106	69.5				
Rear fender overall width	W107	69.7				
Maximum overall car width - front doors open	W120	152.8	135.3	152.8		135.3
Maximum overall car width - rear doors open	W121	--	132.1	--		132.1

(a) Models with 8 cyl. engine.

AMA Specifications – Passenger Car

MAKE OF CAR COMET MODEL YEAR 1965 DATE ISSUED 9-1-64 REVISED(•)

EXTERIOR LENGTH DIMENSIONS

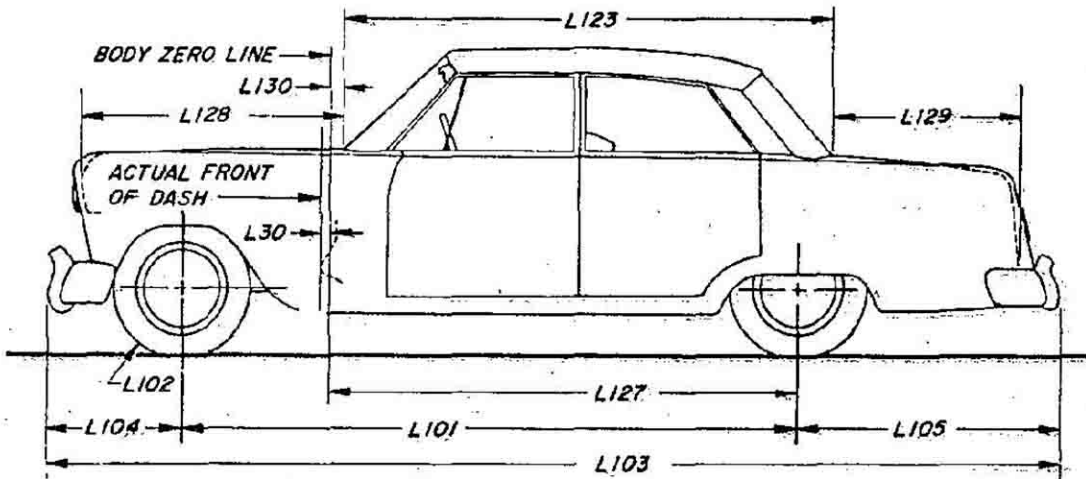

MODEL	Ref. No.	62	54	63	76	71
Body zero line to actual front of dash	L30	-1.0				
Wheelbase	L101	114.0				109.5
Overhang - front	L104	31.1				
Overhang - rear	L105	50.2				51.2
Overall length	L103	195.3				191.8
Hood length at car centerline	L128	54.7				
Body upper structure length at car centerline	L123	97.0		89.8	92.0	124.5
Deck length at car centerline	L129	40.2		47.4	45.6	
Body zero line to centerline of rear wheels	L127	99.7				95.2
Body zero line to windshield cowl point	L130	10.4				
Tire size	L102	6.95 x 14		7.35 x 14 (a)		

(a) Model 76 289 CID V-8 with air conditioning.

AMA Specifications— Passenger Car

MAKE OF CAR COMET MODEL YEAR 1965 DATE ISSUED 9-1-64 REVISED (*)

EXTERIOR HEIGHT DIMENSIONS

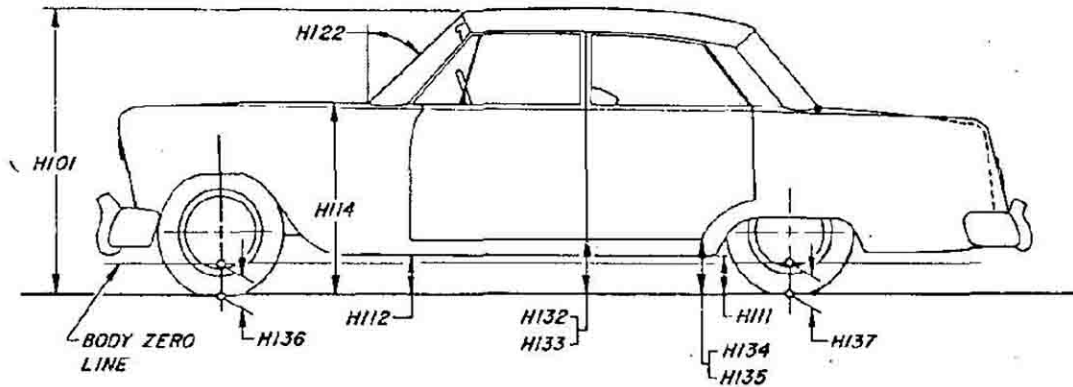

MODEL	Ref. No.	62	54	63	76	71
Overall height	H101	55.2		53.5	54.1	55.2
Hood at rear to ground	H114	37.7				
Rocker panel to ground - front	H112	8.6				
Rocker panel to ground - rear	H111	8.4				
Bottom of door to ground, open - front	H132	12.9	12.7	12.9	12.9	12.9
Bottom of door to ground, closed - front	H133	11.7				
Bottom of door to ground, open - rear	H134	--	12.1	--		12.1
Bottom of door to ground, closed - rear	H135		11.7	--		11.7
Windshield slope angle	H122	51.7°		52.9°		51.7°
Body zero to ground - front	H136	11.0				
Body zero to ground - rear	H137		11.0			

AMA Specifications—Passenger Car

MAKE OF CAR COMET MODEL YEAR 1965 DATE ISSUED 9-1-64 REVISED(•)

GROUND CLEARANCE DIMENSIONS

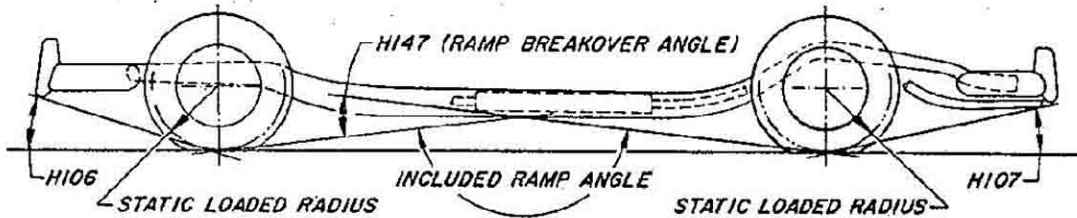
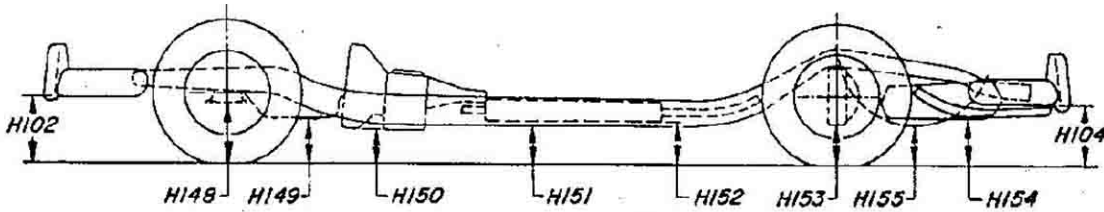

MODEL	Ref. No.	62	54	63	76	71
Front bumper to ground	H102	11.9				
Rear bumper to ground	H104	10.9				10.0
Angle of approach	H106	26.9°				
Angle of departure	H107	13.4°				11.8°
Ramp breakover angle	H147	13.1°			13.7°	12.8°
Front suspension to ground	H148	7.5				
Oil pan to ground	H149	7.9	6.7 (a)			
Flywheel housing to ground	H150	6.8	6.6 (a)		6.8	
Frame structure to ground	H151	8.1				
Exhaust system to ground	H152	7.1	5.9 (a)	6.3 (a)(b)		
Rear axle differential to ground	H153	7.6	6.7 (a)		6.7	
Fuel tank to ground	H154	10.5				11.1
Spare tire well to ground	H155	--				7.4
Minimum running ground clearance	H156	5.9				

(a) Models with 8 cyl. engine.
 (b) Model 76.

AMA Specifications—Passenger Car

MAKE OF CAR COMET MODEL YEAR 1965 DATE ISSUED 9-1-64 REVISED (•)

FRONT COMPARTMENT DIMENSIONS

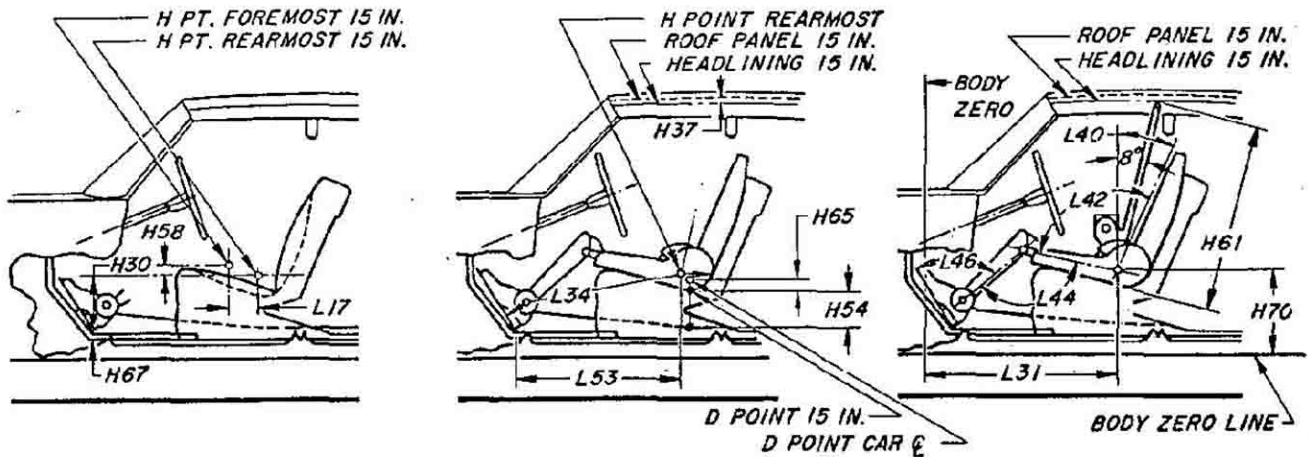

MODEL	Ref. No.	62	54	63	76	71
H Point to body zero line	L31	43.7				
H Point to body zero line - front	H70	8.9				
Effective head room	H61	38.4		36.8	38.1	38.3
Headlining to roof height	H37	.8			--	.8
Maximum effective leg room - accelerator	L34	41.8				
H Point to heel point	H30	9.3				
Depressed floor covering thickness	H67	.5				
Back angle	L40	23°				
Hip angle	L42	96°				
Knee angle	L44	128.5°				
Foot angle	L46	85.5°				
D Point differential, side to center	H65	.6				
D Point to tunnel	H54	2.3				
H Point to accelerator floor point	L53	34.1				
H Point travel	L17	5.0				
H Point rise	H58	.4				

AMA Specifications – Passenger Car

MAKE OF CAR COMET MODEL YEAR 1965 DATE ISSUED 9-1-64 REVISED(•)

REAR COMPARTMENT DIMENSIONS

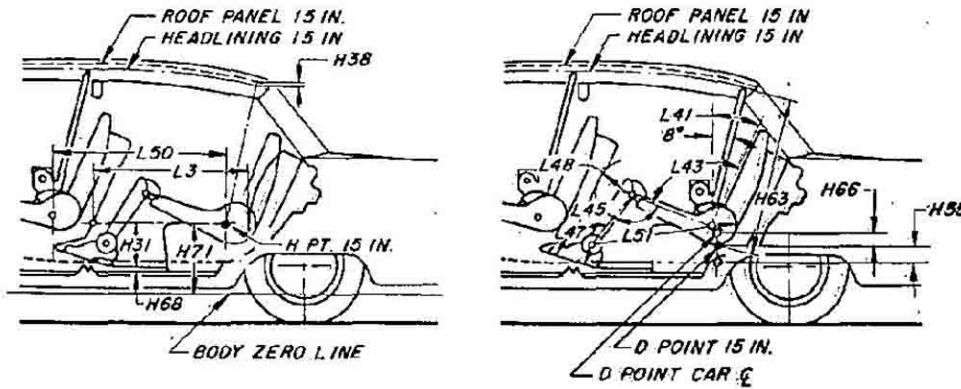

MODEL	Ref. No.	62	54	63	76	71
HiPoint couple distance	L50	32.7		27.3	29.8	32.4
HiPoint to body zero line - rear	H71	9.2		7.6	7.4	10.4
Effective head room	H63	36.9		35.9	37.4	36.8
Headlining to roof height	H38	.8		1.2	--	.8
Minimum effective leg room	L51	35.5		29.8	32.3	35.5
HiPoint to heel point	H31	11.4		9.9	9.6	12.7
Depressed floor covering thickness	H68	.5				
Minimum knee room	L48	3.8		-.6	2.3	2.9
Rear compartment room	L3	27.7		22.4	25.1	26.8
Back angle	L41	26.3°		20°	26°	26.5°
Hip angle	L43	89.5°		73.5°	79.5°	92°
Knee angle	L45	92.5°		78.8°	79°	98°
Foot angle	L47	120°		114°	115.5°	117°
D Point differential, side to center	H66	.7			--	--
D Point to tunnel	H55	2.4		.6		3.0

AMA Specifications – Passenger Car

MAKE OF CAR COMET MODEL YEAR 1965 DATE ISSUED 9-1-64 REVISED(•) _____

SEAT AND ENTRANCE DIMENSIONS

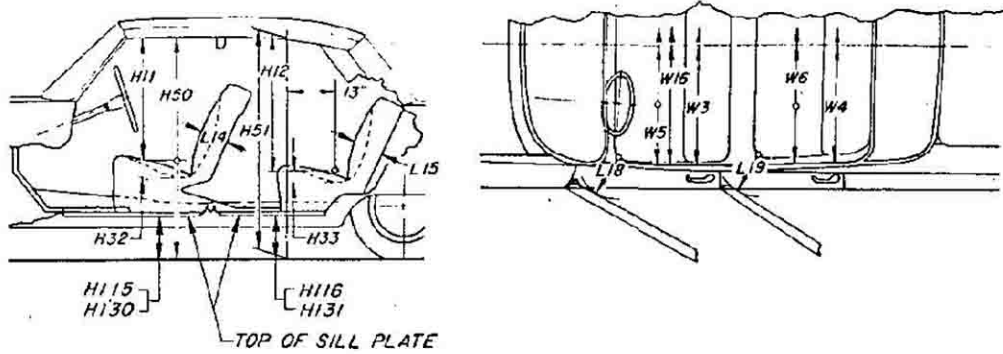

	Ref. No.	62	54	63	76	71
Shoulder room - front	W3	55.4				
Hip room - front	W5	57.1				
Seat width - front	W16	53.3				
Upper body opening to ground - front	H50	50.0		48.6		49.9
Entrance height - front	H11	30.1		28.7		30.0
Step height - front (design load)	H115	13.2				13.2
Step height - front (curb load)	H130	15.2				
Entrance foot clearance - front	L18	11.9				
Seat cushion deflection - front	H32	4.1				
Seat back thickness - front	L14	5.9				
Shoulder room - rear	W4	55.0		54.1	45.6	54.9
Hip room - rear	W6	56.6		56.5	45.0	56.5
Upper body opening to ground - rear	H51	--	49.6	--		49.7
Entrance height - rear	H12	--	29.4	--		28.3
Step height - rear (design load)	H116	--	13.2	--		13.2
Step height - rear (curb load)	H131	--	15.6	--		15.6
Entrance foot clearance - rear	L19	10.9	10.7	10.9	10.9	9.0
Seat cushion deflection - rear	H33	4.5		3.9	4.5	4.1
Seat back thickness - rear	L15	5.3		5.0	6.0	4.6

AMA Specifications - Passenger Car

Page 29

MAKE OF CAR COMET MODEL YEAR 1965 DATE ISSUED 9-1-64 REVISED()

VISION AND CONTROL DIMENSIONS

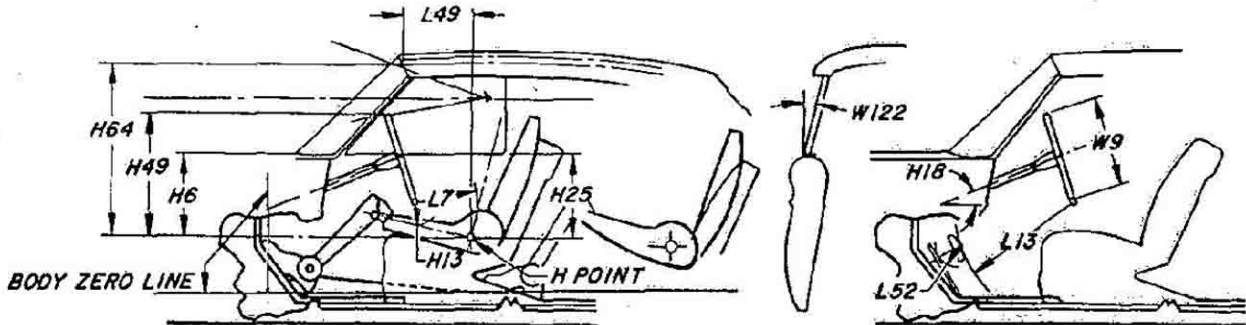

MODEL	Ref. No.	62	54	63	76	71
H Point to windshield bottom DLO	H6	19.2				
H Point to windshield upper DLO	H64	32.4		29.8		32.4
H Point to windshield upper DLO	L49	12.9		14.3		12.9
Belt height - front	H25	16.6				
Steering wheel center to centerline of car	W7	15.0				
Steering wheel maximum outside diameter	W9	16.0				
Steering column angle - horizontal	H18	25.3°				
H Point to top of steering wheel	H49	21.9				
Steering wheel torso clearance	L7	11.5				
Steering wheel thigh clearance	H13	4.0				
Brake pedal knee clearance	L13	25.3				
Brake pedal to accelerator	L52	3.3				
Tumble-home	W122	12.5°		12.5°		12.5°

NOTE: Dimensions for "Bucket Seat" models not available.

AMA Specifications – Passenger Car

MAKE OF CAR COMET MODEL YEAR 1965 DATE ISSUED 9-1-64 REVISED(•)

LUGGAGE COMPARTMENT

MODEL	Ref. No.	62	54	63	76
Usable luggage capacity (See instructions)		13.5		15.3	10.7
Liftover height	H195	29.2			
Position of spare tire storage		In Trunk - Horizontal behind right wheel house			
Method of holding lid open		Torsion bar			

THIRD SEAT DIMENSIONS

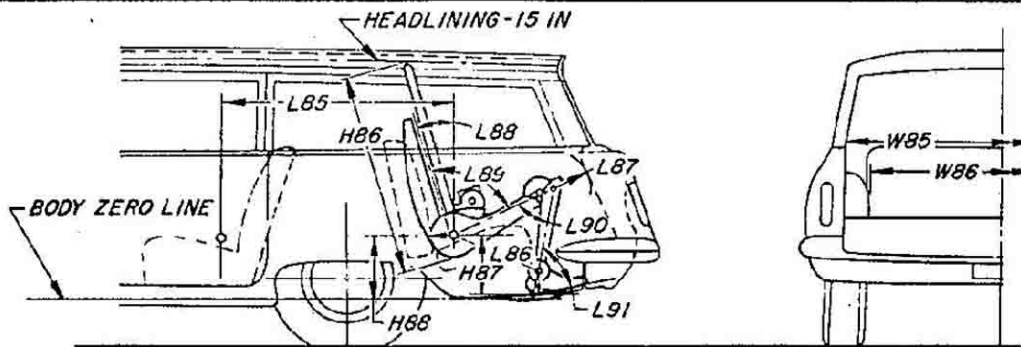

MODEL	Ref. No.	
Seat facing direction		
Shoulder room	W85	
Hip room	W86	
H Point couple distance	L85	
H Point to body zero line - third seat	H88	
Effective head room	H86	THREE SEAT MODEL NOT AVAILABLE
Effective leg room	L86	
H Point to heel point	H87	
Knee room	L87	
Back angle	L88	
Hip angle	L89	
Knee angle	L90	
Foot angle	L91	

AMA Specifications - Passenger Car

MAKE OF CAR	COMET	MODEL YEAR	1965	DATE ISSUED	9-1-64	REVISED	(*)
MODEL	62	54	63	76	71		

BODY - MISCELLANEOUS INFORMATION

Drs. hinged (front, rear)	Front doors						
	Rear doors						
Type of finish (lacquer, enamel, other)							Enamel
Hood counterbalanced (yes, no)							Yes
Hood release control (internal, external)							External
Vehicle (Serial) No. Location	The official serial No. is stamped on the left cowl-to-front spring pocket strut.						
Engine No. Location	Boss on front left side of cylinder block						
Theft protection - type	Door locks, ignition key start, theft retarder ignition switch						
Vent window control method (crank, friction pivot)	Front	Friction pivot					
	Rear	None					
Seat cushion type	Front	Formed wire					
	Rear	Formed wire					
	3rd seat	None					
Seat back type	Front	Formed wire					
	Rear	Formed wire					
	3rd seat	None					
Windshield glass type (i.e., single curved - laminated plate)	Compound curved, laminated sheet, one piece						
Backlight glass type (i.e., compound curved - tempered plate, three piece)	Compound curved, tempered plate and/or sheet, one piece vinyl chloride copolymer sheet - Model 76. Flat, tempered sheet, one piece - Model 71.						
Side glass type (i.e., curved - tempered plate)	Flat, tempered plate						
Side glass exposed surface area	1087.9	953.6	1231.3	1186.1	2417.4		
Windshield glass exposed surface area	1300.5	1300.5	1066.0	1066.0	1300.5		
Backlight glass exposed surface area	905.4	905.4	1071.6	870.0	607.5		
Total glass exposed surface area	3293.8	3159.5	3368.9	3124.1	4325.4		

BODY - CONVENIENCE EQUIPMENT (Indicate whether standard, optional or NA on each series)

Power windows	Side Windows						Not available
	Vent Windows						Not available
	Backlight or tailgate						Optional Standard on Model 71C
Power seats (specify type as well as availability)	Not available						
Reclining front seat back	Not available						
Front seat headrest	Not available						
Radios (specify type as well as availability)	Push Button, Optional						
Rear seat speaker	Optional						
Power Antenna	Not available						
Clock	Optional						
Air Conditioner (specify type and availability)	Recirculating, optional						

AMA Specifications—Passenger Car

MAKE OF CAR COMET MODEL YEAR 1965 DATE ISSUED 9-1-64 REVISED(*)

STATION WAGON—CARGO SPACE DIMENSIONS

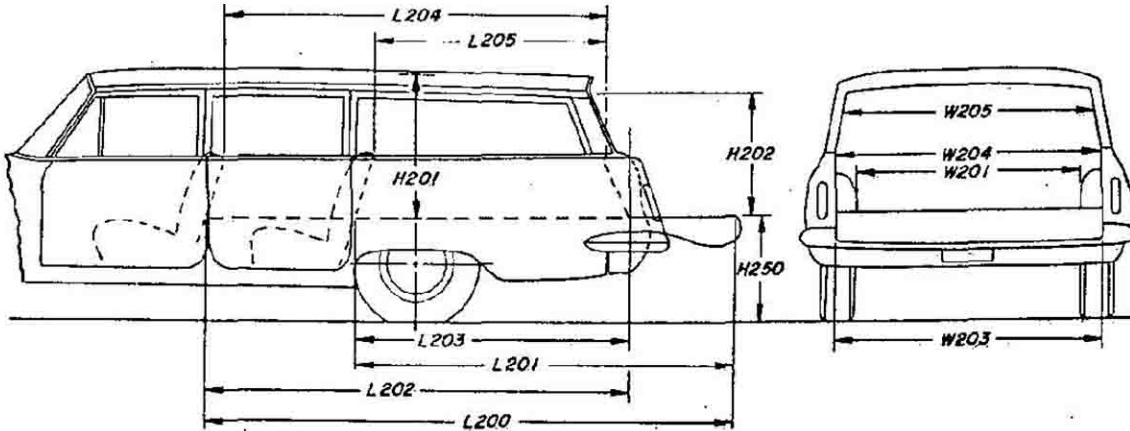

MODEL	Ref. No.	71
Floor length from back of front seat at floor level to end of lowered tail gate or floor	L200	104.8
Floor length from back of second seat at floor level to end of lowered tail gate or floor	L201	72.6
Floor length from back of front seat at floor level to inside of closed tail gate	L202	85.6
Floor length from back of second seat at floor level to inside of closed tail gate	L203	53.3
Minimum horizontal distance from top rear of front seat back to inside of tail gate at belt	L204	74.3
Minimum horizontal distance from top rear of second seat back to inside of tail gate at belt	L205	42.3
Maximum width of cargo space at floor - specify location	W200	56.7
Minimum distance between wheel houses at floor level	W201	42.0
Rear end opening width at floor	W203	45.5
Rear end opening width at belt	W204	45.5
Maximum width of rear opening above belt	W205	44.3
Maximum height - floor covering to headlining at centerline of rear axle	H201	33.0
Maximum height of rear opening - tail and lift gates open	H202	26.6
Platform height from ground to top of tail gate floor covering at rear most edge of tail gate - curb weight	H250	23.3
Rear end closure (e.g., one piece door, hinged left - sliding glass, drop tail gate)		Sliding glass, drop tail gate
Cargo volume index (cu. ft.) W4 x L204 x H201		77.9

172B

AMA Specifications - Passenger Car

MAKE OF CAR COMET MODEL YEAR 1965 DATE ISSUED 9-1-64 REVISED (*)

*Check into file
Bill Ossemmacher, Ford
5-17-65*

WEIGHTS

Model	CURB WEIGHT - POUNDS			% PASS. WEIGHT DISTRIBUTION				SHIPPING * WEIGHT
	Front	Rear	Total	Pass. in Front		Pass. in Rear		
				Front	Rear	Front	Rear	
Comet First Series (202)								
2-Door Sedan 62A	1433	1293	2725	2725				2584
4-Door Sedan 54A	1446	1318	2765	2765				2624
+ 4-Door Sta. Wgn. 71A	1402	1525	2925	2925				2784
Comet Second Series (404)								
2-Door Sedan 62B	1432	1304	2735	2735				2594
2-Door Sedan ① 62C	1447	1317	2765	2765		bucket seats - RPO model		2609
4-Door Sedan 54B	1448	1323	2770	2771				2629
+ 4-Door Sta. Wgn. 71B	1395	1534	2930	2929				2789
+ 4-Door Sta. Wgn. 71C	1396	1537	2930	2933				2789
Comet Third Series Caliente								
4-Door Sedan 54D	1468	1332	2800					2659
2-Door Hardtop - 63D	1482	1347	2825	2829				2684
2-Door Hardtop ② 63C	1497	1360	2855	2857		bucket seats - RPO model		2714
2-Door Convertible 76D	1542	1468	3010					2869
③ 2-Door Convertible 76B	1557	1481	3038	3038		bucket seats - RPO model		2899
Comet Cyclone Series (a)								
2-Door Hardtop 63E	1482	1347	3115	2829				2994
	+ 216	74	+ 290					
	1698	1421		3119				
(a) Includes 289-4V Engine and Bucket Seats with Console (otherwise same wt. as 63D)								
Accessories & Equipment Differential Weights				Remarks				
289 CID 2V Engine	218	71	289	Sedans, Hardtops, Station Wagons				
289 CID 2V Engine			281	Convertible				
289 CID 4V Engine			295	Sedans, Hardtops, Station Wagons				
289 CID 4V Engine			287	Convertible				
Automatic Transmission			20	3-Speed				
Manual Transmission			22	4-Speed, with 8 cyl. Engine				
Air Conditioning	95	3	98					
Power Steering			28					
Power Brakes			8					
Radio and Antenna			7					
Battery, Heavy Duty			11					
Luggage Rack			15	Model 71 only				
① 62C same as 62B except for bucket seats (ft. is 15# heavier; rear 13# heavier; total 28# heavier) ② 63C same as 63D except for bucket seats (ft. is 15# heavier; rear 13# heavier; total, 28# heavier) ③ 76B same as 76D except for bucket seats (ft. is 15# heavier; rear 13# heavier; total 28# heavier)								

* These are weights that are reported to states for licensing purposes.

DIMENSION DEFINITIONS

- W3 SHOULDER ROOM - FRONT. The minimum lateral dimension between the door garnish moldings or nearest interference. Measured at H Point station.
- W4 SHOULDER ROOM - REAR. Measured in the same manner as W3.
- W5 HIP ROOM - FRONT. The lateral dimension through H Point to trimmed surfaces.
- W6 HIP ROOM - REAR. Measured in the same manner as W5.
- W7 STEERING WHEEL CENTER TO CENTERLINE OF CAR. Measured horizontally from steering wheel center to centerline of car. The point at steering wheel center is located in the surface plane of wheel.
- W9 STEERING WHEEL MAXIMUM OUTSIDE DIAMETER. Define if other than round.
- W16 SEAT WIDTH - FRONT. The maximum trimmed width of front seat cushion.
- W85 SHOULDER ROOM - THIRD SEAT. Measured in the same manner as W3.
- W86 HIP ROOM - THIRD SEAT. Measured in the same manner as W5.
- W101 TREAD - FRONT. Measured at centerline of tires, with nominal camber, at ground.
- W102 TREAD - REAR. Measured at centerline of tires at ground.
- W103 MAXIMUM OVERALL CAR WIDTH. Include bumpers, moldings, or sheet metal protrusions.
- W106 FRONT FENDER OVERALL WIDTH. Measured at centerline of front wheels, excluding moldings.
- W107 REAR FENDER OVERALL WIDTH. Measured at centerline of rear wheels, excluding moldings.
- W116 MAXIMUM OVERALL BODY WIDTH. Measured across body, excluding hardware and applied moldings, but including fenders when integral with body.
- W117 MAXIMUM BODY WIDTH AT #2 PILLAR. Measured across body at #2 pillar, excluding hardware and applied moldings.
- W120 MAXIMUM OVERALL CAR WIDTH, FRONT DOORS OPEN. Measured with front doors in maximum hold-open position.
- W121 MAXIMUM OVERALL CAR WIDTH, REAR DOORS OPEN. Measured in same manner as W120.
- W122 TUMBLE-HOME. The angle from vertical to the front door glass outer surface or the chord of a curved door glass, measured at the front H Point station.
- L3 REAR COMPARTMENT ROOM. The horizontal dimension from the back of front seat to front of rear seat back at a height tangent to the top of rear seat cushion.
- L7 STEERING WHEEL TORSO CLEARANCE. The minimum distance from the back edge of steering wheel, in straight-ahead position, to the Torso Line.
- L13 BRAKE PEDAL KNEE CLEARANCE. The minimum dimension from the lower edge of the steering wheel to the brake pedal face centerline.
- L14 SEAT BACK THICKNESS - FRONT. The maximum thickness of the seat back, excluding bolsters.
- L15 SEAT BACK THICKNESS - REAR. Measured in the same manner as L14.
- L17 H POINT TRAVEL. The horizontal dimension between the H Point in the most forward and rearward seat positions.
- L18 ENTRANCE FOOT CLEARANCE - FRONT. The minimum horizontal dimension between seat and normal line of door or pillar at a height between the sill plate bead and 4.0 inches above the bead. Door should be in the maximum hold-open position.
- L19 ENTRANCE FOOT CLEARANCE - REAR. Measured in the same manner as L18 on four-door models. On two-door styles, the minimum dimension between rear corner of front seat, with front seat back tilted forward, and trimmed lock pillar, built-in quarter armrest panel, or rear seat cushion at a height between the sill plate bead and 4.0 inches above the bead.
- L30 BODY ZERO LINE TO ACTUAL FRONT OF DASH. If actual Front of Dash is to the rear of Body Zero Line, it is identified by a minus (-) sign.
- L31 H POINT TO BODY ZERO LINE - FRONT. Horizontal dimension.
- L34 MAXIMUM EFFECTIVE LEG ROOM - ACCELERATOR. Measured along a diagonal line from ankle pivot center to H Point plus a constant of 10.0 inches. Measured with the right foot on accelerator pedal.
- L40 BACK ANGLE - FRONT. The angle between a vertical line through the H Point and the Torso Line.
- L41 BACK ANGLE - REAR. Measured in the same manner as L40.
- L42 HIP ANGLE - FRONT. The angle between Torso Line and a line extending from knee pivot center to H Point.
- L43 HIP ANGLE - REAR. Measured in the same manner as L42.
- L44 KNEE ANGLE - FRONT. The angle between a line from H Point to knee pivot center and a line from the knee pivot center to the ankle pivot center.
- L45 KNEE ANGLE - REAR. Measured in the same manner as L44.
- L46 FOOT ANGLE - FRONT. The angle between a line extended from the knee pivot center through the ankle pivot center and a line tangent to the sole and heel of monikin bare foot.
- L47 FOOT ANGLE - REAR. Measured in the same manner as L46.
- L48 MINIMUM KNEE ROOM - REAR. The minimum dimension from the knee pivot center to the back of front seat back.
- L49 H POINT TO WINDSHIELD UPPER DLO. The horizontal dimension from H Point to the point of tangency of horizontal line of vision (described in dimension H64) with body upper structure.

DIMENSION DEFINITIONS (cont.)

- L50 H POINT COUPLE DISTANCE. The horizontal dimension from the front seat H Point to the rear seat H Point.
- L51 MINIMUM EFFECTIVE LEG ROOM – REAR. Measured along a diagonal line from ankle pivot center to H Point plus a constant of 10.0 inches. Measured with the foot positioned to nearest interference between seat structure and toe, instep or lower leg.
- L52 BRAKE PEDAL TO ACCELERATOR. The minimum dimension from center of brake pedal face to accelerator. Measured in the side view.
- L53 H POINT TO ACCELERATOR FLOOR POINT. The horizontal dimension from intersection of accelerator and depressed floor covering to the H Point.
- L85 H POINT COUPLE DISTANCE – THIRD SEAT. The horizontal dimension from the second seat H Point to the third seat H Point.
- L86 EFFECTIVE LEG ROOM – THIRD SEAT. Measured in the same manner as L51. With rear-facing third seat, foot is positioned in foot well or to nearest interference with rear end or rear closure.
- L87 KNEE ROOM – THIRD SEAT. Measured in the same manner as L48. With rear-facing third seat, dimension is measured to rear closure.
- L88 BACK ANGLE – THIRD SEAT. Measured in the same manner as L40.
- L89 HIP ANGLE – THIRD SEAT. Measured in the same manner as L42.
- L90 KNEE ANGLE – THIRD SEAT. Measured in the same manner as L44.
- L91 FOOT ANGLE – THIRD SEAT. Measured in the same manner as L46.
- L101 WHEELBASE.
- L102 TIRE SIZE.
- L103 OVERALL LENGTH. Include bumper guards if standard equipment.
- L104 OVERHANG – FRONT. Measured from C/L of front wheels to front of car, including bumper guards if standard equipment.
- L105 OVERHANG – REAR. Measured from C/L of rear wheels to rear of car, including bumper guards if standard equipment.
- L123 BODY UPPER STRUCTURE LENGTH AT CAR CENTERLINE. The horizontal dimension from the theoretical intersection of extended windshield glass plane and normal cowl surface to the theoretical intersection of extended back window glass plane and normal deck surface; or in the case of a Fastback roof or Station Wagon, to back glass lower reveal molding, or rubber when molding is not used.
- L127 BODY ZERO LINE TO CENTERLINE OF REAR WHEELS. A horizontal dimension.
- L128 HOOD LENGTH AT CAR CENTERLINE. The horizontal dimension from the foremost point on sheet metal hood surface, excluding series identification or ornamentation, to the theoretical intersection of extended windshield glass plane and normal cowl surface.
- L129 DECK LENGTH AT CAR CENTERLINE. The horizontal dimension from the rearmost point of the body sheet metal (visible above bumper), excluding series identification or ornamentation, to the theoretical intersection of extended back window glass plane and normal deck surface.
- L130 BODY ZERO LINE TO WINDSHIELD COWL POINT. The horizontal dimension from body zero line to the theoretical intersection of extended windshield glass plane and normal cowl surface.
- H6 H POINT TO WINDSHIELD BOTTOM DLO. Vertical dimension.
- H11 ENTRANCE HEIGHT – FRONT. The vertical dimension from H Point to upper trimmed body opening.
- H12 ENTRANCE HEIGHT – REAR. The vertical dimension from H Point to the upper trimmed body opening at a section 13.0 inches forward of the H Point.
- H13 STEERING WHEEL THIGH CLEARANCE. The minimum dimension from the bottom of steering wheel, in straight-ahead position, to centerline of thigh.
- H18 STEERING COLUMN ANGLE – HORIZONTAL. The angle the centerline of steering column makes with the horizontal.
- H25 BELT HEIGHT – FRONT. The vertical dimension from H Point to bottom of side window DLO.
- H30 H POINT TO HEEL POINT – FRONT. The vertical dimension from the H Point to the manikin accelerator heel point on the depressed floor covering.
- H31 H POINT TO HEEL POINT – REAR. The vertical dimension from the H Point to the manikin heel point on the depressed floor covering.
- H32 SEAT CUSHION DEFLECTION – FRONT. The vertical dimension from a point on the undepressed seat cushion to the depressed seat cushion. Measured at the H Point station.
- H33 SEAT CUSHION DEFLECTION – REAR. Measured in the same manner as H32.
- H37 HEADLINING TO ROOF HEIGHT – FRONT. The dimension from the intersection of the headlining and the extended effective head room line to the roof panel. Measured perpendicularly to the roof panel.
- H38 HEADLINING TO ROOF HEIGHT – REAR. Measured in the same manner as H37.
- H49 H POINT TO TOP OF STEERING WHEEL. The vertical dimension from the H Point to top of steering wheel, in straight-ahead position.
- H50 UPPER BODY OPENING TO GROUND – FRONT. The vertical dimension from a point on the trimmed body opening to the ground. Measured at the H Point station.
- H51 UPPER BODY OPENING TO GROUND – REAR. The vertical dimension from a point on the trimmed body opening to the ground. Measured 13.0 inches forward of the H Point.

DIMENSION DEFINITIONS (cont.)

- H54 D POINT TO TUNNEL - FRONT. The vertical dimension from the D Point, at car centerline, to top of tunnel.
- H55 D POINT TO TUNNEL - REAR. Measured same manner as H54.
- H58 H POINT RISE. The vertical dimension between the H Point in the most forward and rearward seat position.
- H61 EFFECTIVE HEAD ROOM - FRONT. The dimension from H Point to the headlining, plus a constant of 4.0 inches. Measured along a line 8° to rear of vertical.
- H63 EFFECTIVE HEAD ROOM - REAR. Measured same as H61.
- H64 H POINT TO WINDSHIELD UPPER DLO. Vertical dimension from H Point to highest horizontal line of vision through windshield at 15 inch section.
- H65 D POINT DIFFERENTIAL, SIDE TO CENTER - FRONT. Vertical dimension from side occupant to center occupant D Point.
- H66 D POINT DIFFERENTIAL, SIDE TO CENTER - REAR. Measured in the same manner as H65.
- H67 DEPRESSED FLOOR COVERING THICKNESS - FRONT. The vertical dimension from manikin accelerator heel point normally to underbody sheet metal immediately below heel point.
- H68 DEPRESSED FLOOR COVERING THICKNESS - REAR. Measured same as H67.
- H70 H POINT TO BODY ZERO LINE - FRONT. Vertical dimension.
- H71 H POINT TO BODY ZERO LINE - REAR. Vertical dimension.
- H86 EFFECTIVE HEAD ROOM - THIRD SEAT. Measured in the same manner as H61.
- H87 H POINT TO HEEL POINT - THIRD SEAT. Measured in the same manner as H31.
- H88 H POINT TO BODY ZERO LINE - THIRD SEAT. Vertical dimension.
- H101 OVERALL HEIGHT. Measured with full design load.
- H102 FRONT BUMPER TO GROUND. Minimum dimension.
- H104 REAR BUMPER TO GROUND. Minimum dimension.
- H106 ANGLE OF APPROACH. The angle between the ground and a line tangent to the front tire static loaded radius arc and the first point of interference, i.e. bumper, guard, gravel deflector, fender or other interfering component, excluding license plate.
- H107 ANGLE OF DEPARTURE. The angle between the ground and a line tangent to the rear tire static loaded radius arc and the first point of interference, i.e. bumper, guard, gravel deflector, tail pipe, fender or other interfering component, excluding license plate.
- H111 ROCKER PANEL TO GROUND - REAR. The vertical dimension from ground to bottom of rocker panel, excluding flanges. Measured at front of rear wheel opening.
- H112 ROCKER PANEL TO GROUND - FRONT. The vertical dimension from ground to bottom of rocker panel, excluding flanges. Measured at foremost point of rocker panel.
- H114 HOOD AT REAR TO GROUND. Measured from hood opening line on shroud, exclusive of moldings.
- H115 STEP HEIGHT - FRONT (DESIGN LOAD). The vertical dimension from top of sill plate bead, at C/L of front door sill plate, to ground.
- H116 STEP HEIGHT - REAR (DESIGN LOAD). Measured in same manner as dimension H115.
- H122 WINDSHIELD SLOPE ANGLE. The angle between a vertical line and the windshield surface at car centerline. On compound-curved windshields the chord of the arc is used and limited to that section of the windshield comprehended by an 18-inch chord.
- H130 STEP HEIGHT - FRONT (CURB LOAD). The vertical dimension from top of sill plate, at C/L of front door sill plate, to ground.
- H131 STEP HEIGHT - REAR (CURB LOAD). Measured same as H130.
- H132 BOTTOM OF DOOR TO GROUND, OPEN - FRONT. Measured from bottom outside corner of door with door in maximum hold-open position.
- H133 BOTTOM OF DOOR TO GROUND, CLOSED - FRONT. Same point on door as H132 dimension, with door closed.
- H134 BOTTOM OF DOOR TO GROUND, OPEN - REAR. Measured in same manner as H132.
- H135 BOTTOM OF DOOR TO GROUND, CLOSED - REAR. Measured in same manner as H133.
- H136 BODY ZERO TO GROUND - FRONT. A vertical dimension measured at front wheel centerline.
- H137 BODY ZERO TO GROUND - REAR. A vertical dimension measured at rear wheel centerline.
- H147 RAMP BREAKOVER ANGLE. Supplement of included ramp angle (180° minus included ramp angle) over which car can pass without interference; measured with car sitting on a level surface, using lines tangent to arcs of front and rear static loaded radii and intersecting at point on underside of car which defines the smallest angle.
- H148 FRONT SUSPENSION TO GROUND. Minimum clearance from lower control arm inner shaft or lowest point on the car centerline.
- H149 OIL PAN TO GROUND. Minimum clearance measured from sheet metal or drain plug.
- H150 FLYWHEEL/CONVERTER HOUSING AND TRANSMISSION ASSEMBLY TO GROUND. Minimum clearance.
- H151 FRAME STRUCTURE TO GROUND. Minimum clearance measured approximately midway between front and rear axles. In this measurement, cross bars and X-members shall be considered part of frame.
- H152 EXHAUST SYSTEM TO GROUND. Minimum clearance. Specify location.
- H153 REAR AXLE DIFFERENTIAL SYSTEM TO GROUND. Minimum clearance.
- H154 FUEL TANK TO GROUND. Minimum clearance measured from sheet metal or drain plug, but excluding supports or straps.
- H155 SPARE TIRE WELL TO GROUND. Minimum clearance.
- H156 MINIMUM RUNNING GROUND CLEARANCE. Location of measurement on the car is to be clearly recorded.
- H195 LIFTOVER HEIGHT. Vertical dimension from luggage compartment lower opening to ground.

INDEX

SUBJECT	PAGE NO.	SUBJECT	PAGE NO.
Angles of Approach, Departure	25	Lamp Height & Spacing	14
Automatic Transmission	1, 16	Legroom	26, 27, 30
Axis, Steering	21	Lengths - Overall	1, 23
Axle, Rear	1, 17	Lifters, Valve	5
Battery	10	Linings - Clutch, Brake	15, 19
Bearings, Engine	4, 5, 6	Lubrication	6, 7, 15, 16, 17
Belts - Fan, Generator, Water Pump	9	Luggage Capacity	30
Body - General Information, types	Title, 1, 22, 32	Motor, Starting	10
Exterior Dimensions	1, 22, 23, 24	Muffler	7
Interior Dimensions	26, 27, 28, 29, 30	Overdrive	16
Clearance Dimensions	25	Piston Pins & Rings	2, 4
Brakes - Parking, Service, Power	18, 19	Pistons	2
Camber	21	Power Brakes	18
Camshaft	5	Power Steering	20
Capacities		Power Teams	3
Cooling System	9	Propeller Shaft, Universal Joints	16, 17
Fuel Tank	8	Pumps - Oil, Fuel	7, 8
Lubricants		Water	9
Engine Crankcase	7	Radiator, Hoses	9
Transmission and Overdrive	15, 16	Ramp Break-over Angle	25
Rear Axle	17	Ratios - Axle	1, 3, 17
Carburetor	3, 8	Compression	1, 2, 3
Caster	21	Steering	20
Choke, Automatic	8	Transmission	15, 16
Circuit Breakers, Fuses	14	Rear Axle	1, 3, 17
Clearance, Ground	25	Regulator - Generator	10
Clutch - Pedal Operated	15	Rims	18
Coil, Ignition	11	Rings, Piston	4
Connecting Rods	4	Rods - Connecting	4
Cooling System	9	Shock Absorbers, Front & Rear	19
Crankcase Ventilation	7	Spark Plugs	11
Crankshaft	5	Speedometer	12
Cylinders and Cylinder Head	2	Springs - Front & Rear Suspension	20, 21
Dimension Definitions	34, 35, 36	Valve, Engine	6
Distributor - Ignition	11	Stabilizer (Sway Bar) - Front & Rear	20, 21
Electrical System	10, 11, 12, 13, 14	Starting Motor	10
Engine		Steering	20, 21
Bore, Stroke, Displacement, Type	1, 2	Suppression - Ignition, Radio	11
Compression Ratio	1, 2	Suspension - Front & Rear	19, 20, 21
Firing Order, Cylinder Numbering	2, 11	Switches	12
General Information, H.P. & Torque	1, 2	Tailpipe	7
Lubrication	6, 7	Thermostat, Cooling	9
Power Teams	3	Timing, Engine & Valve	5, 6, 11
Exhaust System	7	Tires	1, 18
Equipment Availability	32	Tie in	21
Fan, Cooling	9	Torque Converter	16
Filters - Engine Oil, Fuel System	7, 8	Torque - Engine, Rated	1, 2, 3
Frame	19	Transmission - Types	1, 3, 8, 15, 16
Front Suspension	19, 20	Automatic	1, 3, 8, 15, 16
Fuel, Fuel Pump, Fuel System	1, 2, 8	Manual & Overdrive	1, 3, 8, 15, 16
Fuel Injection	1, 8	Ratios	15, 16
Fuses, Circuit Breakers	14	Tread	1, 22
Generator and Regulator	10	Trunk Luggage Capacity	30
Glass	24, 32	Turning Diameter	20
Height (Lamps)	14	Unitized Construction	19
Headroom - Body	26, 27, 30	Universal Joints, Propeller Shaft	16, 17
Heights - Overall	1, 24	Valves - Intake & Exhaust	5, 6
Hood	23	Vibration Damper	5
Horns	12	Voltage Regulator	10
Horsepower - Brake, Taxable	1, 2, 3	Water Pump	9
Ignition System	11	Weights - Shipping, Curb	33
Inflation - Tires	18	Wheel Alignment	21
Instruments	7, 12	Wheelbase	1, 23
Kingpin (Steering Axis)	21	Wheels & Tires	18
Lamp Bulbs	13	Wheel Spindle	21
		Widths - Car & Body	1, 22
		Windshield	24, 32
		Windshield Wiper	12