

THAT "CRAZY" MANIFOLD

by ROGER HUNTINGTON

Technically known as Tuned Induction or Ram Tuning, Chrysler Products' new carburetor plumbing really works. Here's why . . .

Probably the last really important development in intake manifold design was brought out by Chrysler on the 1929 straight-8 models—the dual "180-degree" layout with dual downdraft carburetor. We've been cleaning up details since then. Or that is up until the 1960 Chrysler Corporation models. Today we have not one, but *two*, vital new manifold developments to study, evaluate, and put to work: The "inertia ram" principle on that crazy curved manifold for the new Dodge-Plymouth-Valiant slant six, and the "resonant ram" principle on the new Sonoramic V8 setups. Either or both developments could revolutionize U.S. manifold development within three years.

Admittedly there have been reams of copy put out on these developments in the last few months. But I don't think we get down to the *meat* of the subject—down to the why and the wherefore, and how we might apply some of the principles learned to making our own equipment perform better. An afternoon spent with Chrysler manifold engineers brings out new factors and angles that haven't even been hinted at in all those reams of earlier copy. Let's have a look. . . .

RAMMING WITH INERTIA

Chrysler's new inclined overhead valve six for the Dodge Dart, Plymouth and Valiant lines has altogether unusual high-end performance when judged by all the usual performance factors like compression ratio, valve timing, port and valve size, piston speed, etc. Specifically, the true horsepower output *per cubic inch* is excellent—and the hp curve has an unusually flat peak between 4000 and 5000 rpm, so hp doesn't nosedive just beyond the peak as it does on most engines. The engine *shouldn't* perform this way. But it does . . . and there's got to be a reason. And this reason just about has to involve

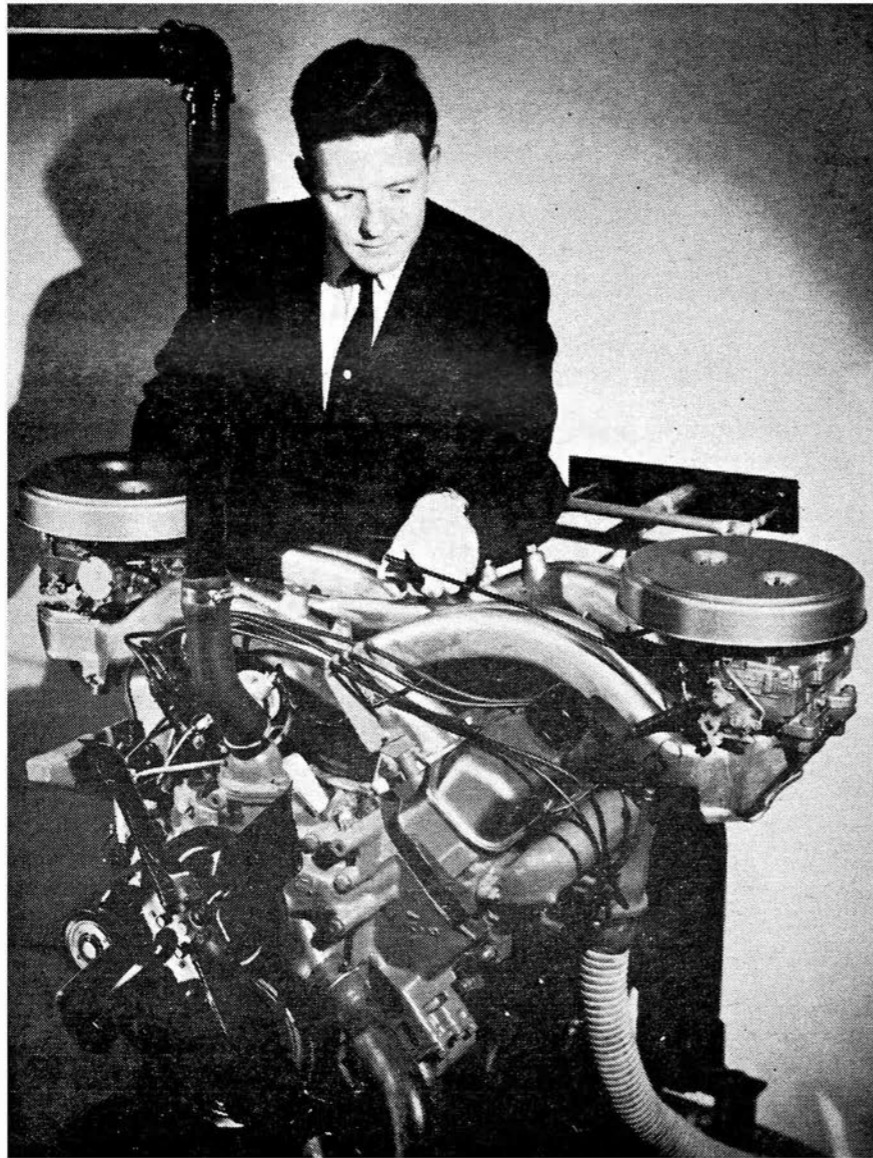

Plymouth Chief Engr. Jack Charipar with SonoRamic Induction system on test stand. Inertia of intake charge is boosted through long ducting, aiding engine performance.

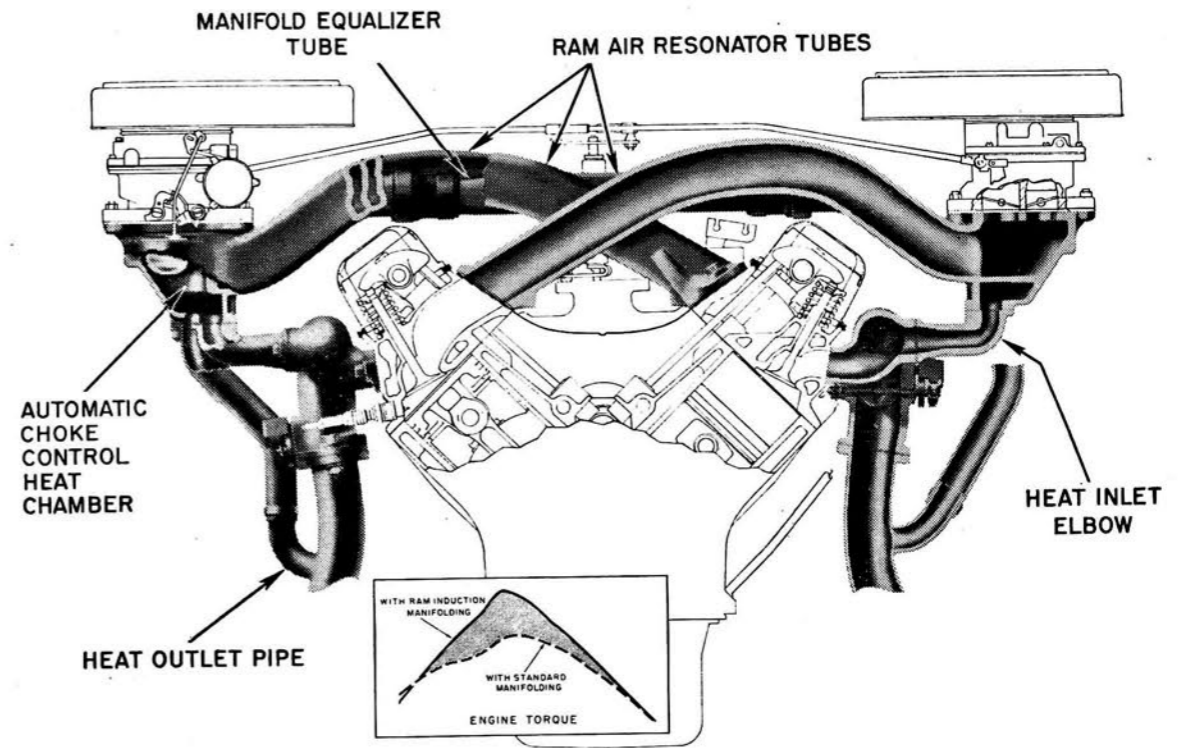

This cross-section gives general layout of 1960 Sonoramic V8 resonant induction system; passage length is 29-30 inches, tunes at 2800 rpm, with 10% torque gain. Note relative improvement in engine torque (inset box).

breathing, since the relatively low compression ratio and high piston speed would both tend to give a sharper power peak at lower rpm, and less peak horsepower.

Then the key is in that crazy manifold.

Look at it this way: When the piston moves down on the suction stroke it draws a column of fuel-air mixture from the chamber below the carburetor, through the manifold, port and valve, and into the cylinder. The mixture will reach a quite high velocity—maybe between 200 and 300 feet per second—during this transfer. When the piston comes to a stop at the end of the suction stroke the *momentum or inertia* of this fast-traveling mass of mixture *will continue to pack it into the cylinder*. This is why we leave the intake valve open long after the piston reaches bottom center, to let this inertia-propelled mixture in.

Okay. So doesn't it make a lot of sense to try to *increase* the inertia of the column of fuel-air mixture? You'll recall from your high school physics that inertia depends on the mass or weight of a body and its velocity. Thus we can increase inertia by increasing either the mass of the fuel-air column or its velocity, or both. Actually these are conflicting requirements. To increase the mixture velocity at any rpm we would need to use *smaller* manifold passages and ports—while to get more mass we would need to make them *larger*. Also we must remember that smaller passages and higher velocity increase the *skin friction* effect holding back the air flow—so we might

end up with little net gain in breathing.

Chrysler engineers did the only logical thing and made the manifold passages *longer*. This got them the extra mass for the inertia ram effect, while permitting reasonably large-area passages to control skin friction. That's the whole secret in a nutshell.

Of course there was more to it than that. Most important, any manifold for an in-line 6-cylinder engine that has a relatively long individual passage for each cylinder is going to take up a lot of space on one side of the engine. It would have to be in the familiar "banana bunch" shape, and would need to extend some 12 or 15 inches out from the head ports. With a conventional vertical engine installation there just isn't room—at least not without considerable chopping and cobbling in the fender well area. It was not until Chrysler went to a front end layout with the engine tilted 30 degrees to the right that the inertia ram-type manifold became fully practical. Admittedly they didn't go to the tilted engine primarily to make room for the new manifold; it was done mostly to reduce height and to shorten the engine by allowing the water pump to be inset alongside the block. Chrysler engineers had been experimenting with various types of ram manifolds for at least five years before the '60 models came out—and the tilted engine just gave them the first good opportunity to use one in production. Performance enthusiasts can be thankful they took the plunge.

Furthermore the benefits are not all in brute horsepower. We all know that the distribution of fuel-air mixture between the cylinders of any inline engine with a normal "rake" or log-type manifold tends to be quite uneven. Liquid fuel tends to collect at certain points in the main log, flooding some cylinders and starving others. And this, in turn, means that the carburetor must be jetted rich enough to keep the leanest cylinder from burning valves or misfiring. Overall result is a loss in power and increase in fuel consumption.

The new Chrysler inertia ram manifold is made to order for improving mixture distribution. By splitting the mixture flow to each cylinder right below the carburetor—at the exhaust hot-spot—we can get pretty even mixture ratios to each cylinder. This has been proved by tests using exhaust gas analyzers in each individual exhaust port; they show the new ram layout to be definitely superior to earlier log designs. Admittedly it's not easy to show a substantial margin in miles per gallon out on the highway. This is because the very high vacuum in the manifold at cruising speeds (around 20 inches of mercury) lowers the boiling point of the gasoline, and thus improves vaporization and mixture distribution. The difference between good and bad manifold designs is less noticeable here. But when you open that throttle wide *everything* has to be right—and that's where the new inertia ram manifold with split passages shines.

(Continued on following page)

THAT "CRAZY" MANIFOLD

continued

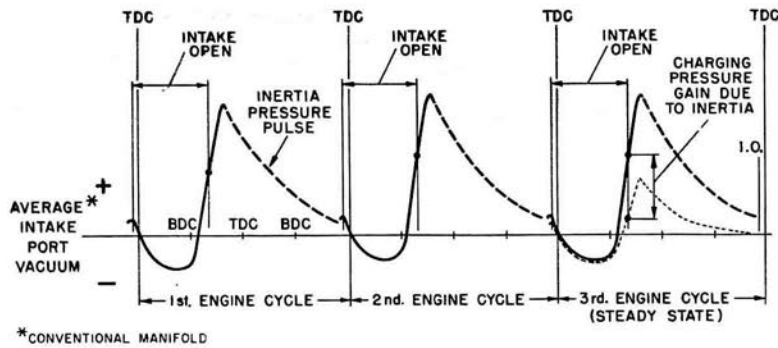

*CONVENTIONAL MANIFOLD

INTAKE PORT PRESSURE
RAM INDUCTION MANIFOLD
—INERTIA EFFECT ONLY—

So the next question: If a *little* extra passage length is good for ram, wouldn't a *lot more* length be better? Why not passages 20 or 30 inches long? Here again we have to compromise. More length means more skin friction, which acts to *restrict* the breathing. Also we couldn't keep long passages warm, so fuel vaporized at the hot-spot under the carb would tend to condense and settle out before it got to the port. And, of course, there's the space problem. So we have to compromise on passage length.

Perhaps we can get some idea of the potential of the inertia ram manifold by looking at the new Valiant power pack (called Hyper-Pak). This uses a big Carter model AFB four-barrel carb (7.09 square inch venturi area) feeding into a large-volume plenum chamber below it, and then into relatively long ducts to the head ports. These passages are somewhat longer than on the stock manifold, and the rough "S" shape of the end runners helps keep all six passages more nearly the *same* length—which is necessary to get any kind of *resonant*, or acoustic, tuning effect. There is said to be a slight resonant effect at around 6000 rpm. Also the longer passage length gives more inertia ram, which is indicated by a very flat peak on the power curve with this manifold. There is little power drop for 400 rpm on each side of the peak. The seemingly large chamber below the carb is necessary to get good throttle response without an exhaust hot-spot. This was quite a problem during development of the manifold; it was eventually found that a low 1/4-inch "dam" cast on the floor of the chamber, just in front of the port passage openings, helped mixture distribution at the top end with no appreciable loss in breathing.

In passing, a word about availability of the Valiant pack: Production limita-

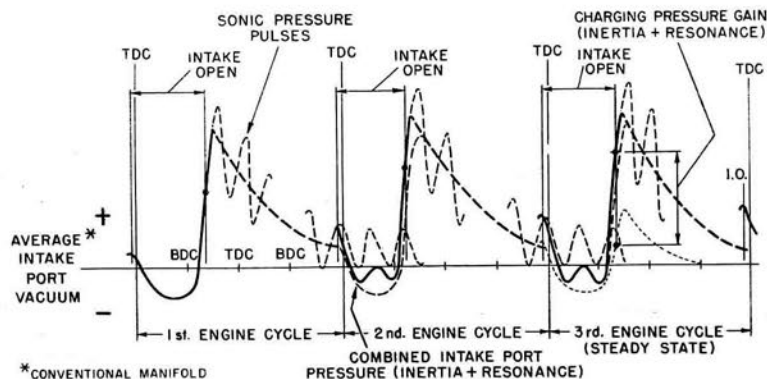
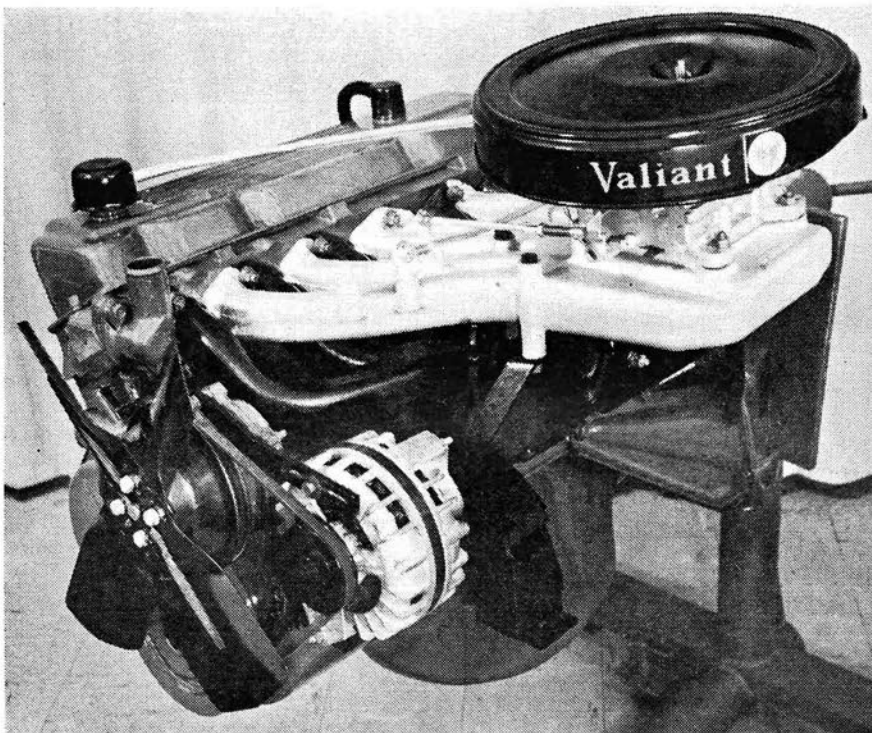

*CONVENTIONAL MANIFOLD

INTAKE PORT PRESSURE
RAM INDUCTION MANIFOLD
INERTIA + SONIC RESONANCE

TOP—The effect of long manifold giving inertia ram at the port when piston stops at end of suction stroke. Finer dash line at right represents conventional manifold.

CENTER—Valiant Hyper-Pak 6 showing inertia-ram manifold; large plenum chamber below carb is necessary to get good throttle response without exhaust hot spot. Carter AFB has 7.09 sq. in. venturi area.

BOTTOM—Effect of inertia ram plus resonant ram on intake port pressure; mixture piling up against shut valve reverberates in passage, gives positive pressure pulse when valve opens (if length is right).

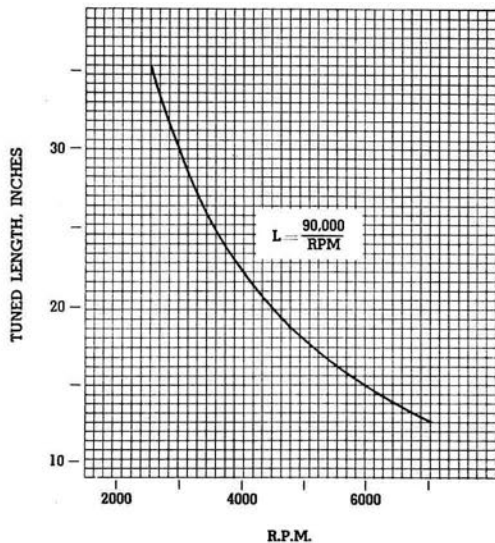

Approximate optimum length for a resonant-tuned induction passage at a specified RPM—measured from valve's head to first major pressure disturbance (venturi, plenum chamber, etc.).

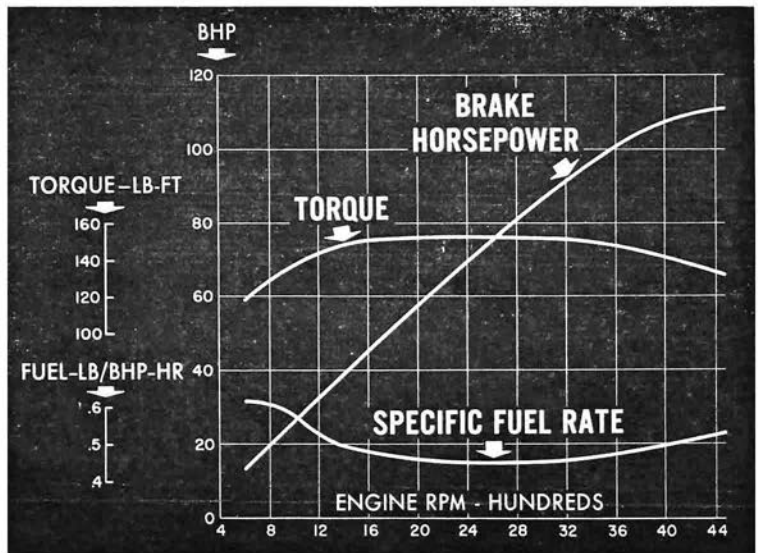

Chart above shows the gross performance curves for lively 170 cubic inch Valiant slant six powerplant running stripped and without accessories; this engine is de-rated for advertising purposes in order that it might remain in the "economy car" class. It does quite well in this category.

tions have made it necessary to distribute the equipment through Mopar as a dealer-installed option, rather than stocking the stuff on the production line. This, in turn, made it impractical to use the 10.5 to 1 high-dome pistons because these have to be selectively fitted. So the kit will consist, essentially, of the manifold and Carter AFB carb, hot cam, tubular pushrods, high-tension valve springs and dampers, dual exhaust manifolds, Y headpipe, reverse-flow low-restriction muffler, tailpipe, parts for offsetting the starter for exhaust clearance, heavy-duty clutch disc, and the necessary linkages, etc. Chrysler rates the package 148 hp at 5200 rpm, and it should just about hit this as installed in the car. This should make it a real threat in the C/Stock class at the drag strip. The Daytona engines averaged 185 hp at 5800 with hand assembly and high compression. Incidentally, the maximum usable rpm on the kit will be 6500-6600 rpm—compared with 7000 on the Daytona engines—because of the single valve springs.

So there's the evidence on inertia ram. A run-of-the-mill engine design that breathes much better than it has any right to; a simple power pack with only 8.5 to 1 compression ratio that develops nearly 1 hp per cubic inch; a high-compression pack that does better than 1 per cubic inch; and all this with very acceptable gas mileage, flexibility and throttle response.

Which leads us to the next step . . .

RESONANT RAM

From the principle of long individual intake manifold passages it's just one more step to a full "tuned" induction system. Here we can utilize the inertia ram of a long fuel/air mixture column plus the

supercharging effect of natural acoustic pressure waves that bounce back and forth in the mixture. Thousands of words have been written on this subject since Chrysler brought out the new Sonoramic installations—so you shouldn't mind my adding two cents' worth!

First of all, let me emphasize that there is anything but universal agreement even on the theory of resonant intake tuning—much less on how to apply theory to a practical manifold design. I was quite surprised about this. For instance, I found Chrysler engineers following an entirely different reasoning than most of the European racing people—and yet they were all coming up with just about the same practical results and length/rpm relationships! Let me explain:

Air—or any gas for that matter—is elastic. Just like a force impact on a coil spring will cause it to spring back and vibrate, so a pressure impulse in the air will cause the air mass to vibrate, or resonate. These pressure impulses can be positive pressure, like when you clap your hands together, or a suction impulse, like when a piston goes down on the intake stroke. These pressure pulses spread through the air mass in all directions in the form of alternate compression and suction waves, traveling at a constant speed of about 1100 feet per second. Thus when the piston sweeps down on the intake stroke the suction wave travels up the induction passage toward the carburetor. When it reaches the open air a positive pressure wave will jump in to fill the vacuum—and, in turn, travel back down the induction passage toward the cylinder, at a speed of 1100 ft./sec. If the induction passage length is just right—for the particular engine rpm, that is—

we will obviously have the pressure wave arriving at the cylinder at the time the intake valve is closing. This will give a slight supercharging effect and an increase in power.

Simple enough. But this isn't the way Chrysler has it figured out. They picture the incoming fuel/air mixture (a relatively heavy mass due to the long induction passage) as piling up against the intake valve head as it closes. This produces a pressure wave that is reflected back and forth through the induction passage three or four times before the valve opens on the next intake stroke. The mixture literally resonates in the induction passage—and they figure to get their boost by having a pressure wave arrive at the valve just at the instant of opening. They don't mention reinforcing the primary piston suction wave at all.

Well, fortunately, Mother Nature is cooperative (for once!)—and they're all right. It so happens that, with normal valve timing, an induction passage length that "tunes" the primary piston suction wave at a given rpm is also just about right for getting the resonant pressure wave (caused by mixture piling up against the rapidly-closing intake valve) back to the valve head at the time it opens for the next intake stroke! Clear as mud, eh?? The important thing is that, even though the slide rule boys don't all agree in principle, they're all getting similar results with similar passage lengths. Thus we can be safe in following their lead—and we can expect similar results, too.

Actually Chrysler engineers have been experimenting with tuned induction systems since 1946! Their early experiments
(Continued on page 98)

GET THE ENGINES THAT
HELP YOU FINISH
WAY OUT FRONT!

- CAST IRON LINERS
- 5.85 C. I. DISPLACEMENT
- BOLTED HEAD
- CAN BE MIRRORED

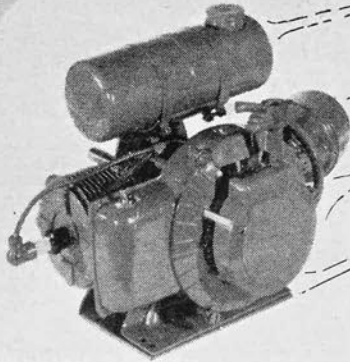

For FREE
Catalog K-1
Write to
Tecumseh
Products Co.
Grafton, Wis.



HOME OFFICE: TECUMSEH, MICHIGAN
ENGINE PLANTS: GRAFTON and NEW HOLSTEIN, WISCONSIN

Delivers the
power and performance
you paid for!



BENDIX* ELECTRIC FUEL PUMP

*Reg. U. S. Pat. Off.

- Maximum fuel delivery instantly!
- More horsepower!
- No vapor lock!
- No fuel flow pulsation!
- Faster starts in cold weather!
- Buy from your dealer—install it yourself!

Bendix-Elmira

Eclipse Machine Division • Elmira, New York



200 MPH

IN THE 1/4 MILE ...

OR 90 MPH IN THE STOCKER CLASS

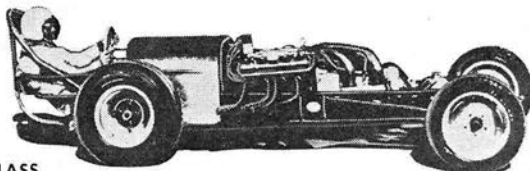

PERMA-CRAFT now offers to all drag race participants a metal photo etched timing plate with a picture of *your* car along with your time, E.T., name of strip, date, etc. You supply the photo of *your* car and timing information and PERMA-CRAFT will *RUSH* to you by return mail a beautiful personalized timing tag for your dash or wallet.

Prompt delivery guaranteed.
Send for your's today! Post paid.....

\$150

PERMA-CRAFT

AMPORT INTERNATIONAL INC.

3319 W. MAGNOLIA BLVD., DEPT. HR
BURBANK, CALIFORNIA

THAT "CRAZY" MANIFOLD

continued from page 47

(you motorcycle fans take note) were with single-cylinder engines, using single-throat carbs. In the late '40's they took out several patents on the designs (though it's doubtful how effective these would be in stopping another company from using something similar to SonoRamic). After the big dome-head Firepower V8 was introduced in 1951 Chrysler Engineering got on quite a performance kick. It ended up with an all-out 331 cubic inch Firepower that developed 447 hp at 5600 rpm on alky—and a team of de-stroked 272 cubic inch Indianapolis engines in 1953 that were said to put out over 350 hp at 6500. All these engines used tuned intake stacks on their Hilborn fuel injectors. Optimum lengths were determined by running the engines on a dynamometer at the desired rpm, then using telescopic tubes on the intakes that could be adjusted in length to get the highest torque reading. Very simple. This was one of the first really effective uses of the principle in the U.S. automotive picture.

The cost problem made it a long, rough road between the Indy dyno tests and the production line. One reason is that the required passage length is *inversely* proportional to the tuned rpm—in other words, the passage length gets longer as the rpm comes down. Space is no problem when you're tuning for 5000 or 6000 rpm; but on a passenger car we're mostly concerned with acceleration in the passing range out on the highway—or engine speeds in the 2000-3500 rpm range. Chrysler chose an effective passage length of 29-30 inches, to tune at 2800 rpm. They solved the space problem by running the passages for one bank of cylinders across the head of the opposite bank, with a four-barrel carburetor feeding into a plenum chamber at the ends of the passages. Chrysler people admit they're 'way out on a limb on costs with this setup—but they felt the performance boost in the *usable* rpm range would be a good enough sales gimmick to make it pay off. The torque improvement at 2800 rpm (over the conventional dual-quad setup) is about 10%, and you can really *feel* it on the road.

Incidentally, it is not generally appreciated among the brotherhood that the power pack Chrysler 300-F models (400 hp) have shortened induction passage lengths that tune at 4400 rpm. To get this effect with the standard manifold castings they have chopped back the partitions between adjacent passages next to the ports to get an effective divided length of about 18 inches. This is a little crude; but they get a definite boost, the tuned manifolds out-pulling conventional dual quads above 4400-4500 rpm.

WHAT DOES IT MEAN TO YOU?

I think the recent manifold developments at Chrysler mean two important things to the amateur speed mechanic: (1) The value of a long individual manifold for each cylinder in assisting breathing at high rpm, and (2) confirmation of a simple formula for calculating optimum tuned passage length for a given rpm. In fact, I think Chrysler research proves that the two effects actually *reinforce* each other—that is, the relatively long passage length necessary to get resonant ram effect in the usable rpm range gives added *inertia ram*, which in turn adds to the resonant tuning effect when the intake valve is closed. This is how Chrysler engineers explain it. With long passages, but not all the same length, you get primarily inertia ram. If they're all the same length (or approximately) you will get inertia ram *plus* resonant ram at some certain RPM, depending on the passage length.

Which brings us to the arithmetic! You will find that all the various formulas for optimum tuned induction pipe length reduce essentially to one very simple relationship:

$$L = \frac{K}{\text{RPM}}$$

where L is the passage length in inches, K is a constant, and RPM is the desired crank speed. If you take an average of all the formulas (and they are all quite similar) you come up with a value for K of somewhere around 90,000. In other words just divide 90,000 by the desired RPM and you've got your intake passage length in inches. For 5500 rpm, for instance, it would be $90,000/5500 = 16.4$ inches. This is the distance *from the valve head*, through the port, through the manifold passage, and up to the *first major pressure disturbance in the air flow path*. This would be the plenum chamber below the carb on the Chrysler setups. With a single carb feeding a single cylinder through a pipe it would be the carb venturi. With log manifolds it would be where the passages connect with the log. With Hilborn injectors there are no major pressure disturbances, and the tuned length would run from the valve to the open air. Get the idea?

And that's about all there is to it. Looking ahead I see strange pictures. I see our conventional short-passage manifolds being suddenly looked upon with a suspicious eye. I see young fellows cobbling up weird plumbing nightmares to mount all kinds of carburetor installations (since you have to have your tuned length below the venturi). I see a new interest in tuned induction systems of all kinds. I think this could be one of the most fascinating fields for experiment and development to hit the hot rod game in a long time.

HOT from Hoffco

2 NEW MODELS

Designed to **OUTPERFORM EVERYTHING** in Their Classes

Hoffco CYCLONE KART

6 Engines available

CLINTON A-490
or E-65-E

WEST BEND 580
Deluxe or 700

POWER PRODUCTS
AH-58 or AH-82

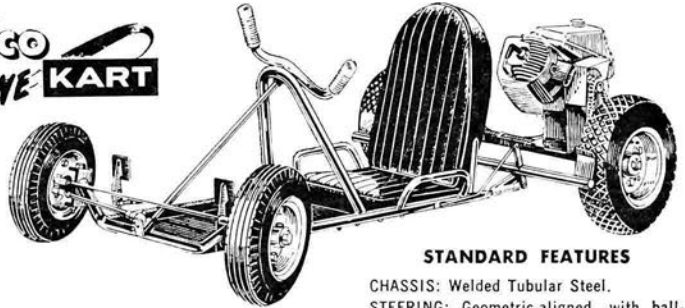

STANDARD FEATURES

CHASSIS: Welded Tubular Steel.
STEERING: Geometric-aligned, with ball-joint rod-ends. Steering wheel ¾" diameter, with hand grips.
WHEELS: Front 10", rear 12" diameter. Heim ball bearings front and rear. Steel hubs with 3-stud interchangeable demountable rims.
SPROCKET DRIVE: Single 84-tooth #35 chain.
CLUTCH: Comet Automatic Centrifugal.
BRAKES: Dual Paddle.
AXLES: ¾" dead axle-rear, ¾" front spindles.

BIG VALUE FOR THE MONEY

The new Hoffco CYCLONE is designed for the man who likes to start with a modest expenditure and add extras as he chooses. It's an expertly engineered, strongly built standard model and you'll go a long way to beat the value at its price. Take your choice of 6 engines. You'll like the CYCLONE—it's a real HOFFCO KART.

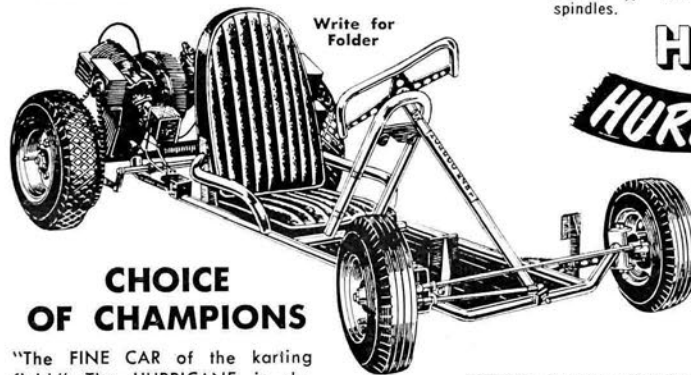

Write for
Folder

Hoffco HURRICANE KART

with
LIVE
AXLE

CHOICE OF CHAMPIONS

"The FINE CAR of the karting field." The HURRICANE is designed for experienced drivers who are looking for advanced engineering and construction as well as improvement in handling, performance and endurance. Pick your engine from the list above. Full kit of racing equipment available. If you want the finest engineered racing machinery in the field—it's yours in the Hoffco HURRICANE. Dealers—Distributors. Write or Wire us.



HOFFCO, INC.
414 N. 8th ST.
RICHMOND, INDIANA

STANDARD FEATURES

CHASSIS: Seamless steel tubing; stress welded.
STEERING: Geometric aligned, aircraft rod ends; bearing-supported. Housed steering column equipped with Oilite bearings. Competition wheel.
WHEELS: Front 10", rear 12" diameter. Interchangeable. Timken Duo-Face sealed bearings front and rear. Hoffco-loy (magnesium) hubs, with 3-stud demountable rims.
SPROCKET DRIVES: Dual sprockets 3/8-P #35. Choice of 60-T, 72-T, 84-T.
CLUTCHES: Comet automatic centrifugal; 12-tooth.
AXLES: ¾" housed live axle; ¾" front spindles.
BRAKES: Dual 4" internal expanding. Positive bar linkage.
UPHOLSTERY: Deluxe. Padded seat & back; floor mat.
FINISH: POWDER BLUE enamel; trim in chrome.

packaged thrust

Transmit full Torque to rear wheels with the new B & M Hydro Stick Transmission. Not beefed up. A completely remanufactured product. Write for complete details.

B&M

AUTOMOTIVE

14530-C Sherman Way, Van Nuys, California • State 5-5895

