

## AMA Specifications – Passenger Car

The information contained herein is prepared, distributed by, and is solely the responsibility of the automobile manufacturing company to whose products it relates. Questions concerning these specifications should be directed to the manufacturer whose address is shown below. This uniform specification form was developed by the automobile manufacturing companies under the auspices of the Automobile Manufacturers Association.

MANUFACTURER <b>CHRYSLER -PLYMOUTH DIVISION CHRYSLER CORPORATION</b>	CAR NAME <b>PLYMOUTH VALIANT PLYMOUTH</b>
MAILING ADDRESS <b>DETROIT 31, MICHIGAN</b>	MODEL YEAR <b>1963</b>
	ISSUED: <b>8-1-62</b> REVISED (•) <b>1-16-63</b>

**NOTES:**

1. The Specifications herein are those in effect at date of compilation and are subject to change without notice by the manufacturer.
2. UNLESS OTHERWISE INDICATED:
  - a. Specifications apply to standard models without optional equipment. Significant deviations are noted.
  - b. Nominal design dimensions are used throughout these specifications.

### TABLE OF CONTENTS

General Specifications . . . . . 1	Drive Units . . . . . 15	Rear Suspension . . . . . 21	Body & Car - General . . . . . 22
Engine - Mechanical . . . . . 2	Brakes . . . . . 18	Body Dimensions . . . . . 22	Weights . . . . . 33
Electrical . . . . . 10	Front Suspension & Steering . . 19	Station Wagon . . . . . 31	Index . . . . . 37

<b>BODY—TYPES AND STYLE NAMES—</b>		Body type, number of passenger & style names; use manufacturer's code for series & body style.						
		VALIANT						
		V-100	V-200	Signet 200				
2-Door Sedan		TV1-L-21	TV1-H-21	--				
2-Door Hardtop		--	--	TV1-P-23				
Convertible Coupe		--	TV1-H-27	TV1-P-27				
4-Door Sedan		TV1-L-41	TV1-H-41	--				
4-Door Sta. Wag., 6-Pass.		TV1-L-45	TV1-H-45	--				
		PLYMOUTH SIX			PLYMOUTH V-8			
		Savoy	Belvedere	Fury	Savoy	Belvedere	Fury	Sport Fury
2-Door Sedan		TP1-L-21	TP1-M-21	---	TP2-L-21	TP2-M-21	--	--
2-Door Hardtop		--	TP1-M-23	TP1-H-23	--	TP2-M-23	TP2-H-23	TP2-P-23
Convertible Coupe		--	--	--	--	--	TP2-H-27	TP2-P-27
4-Door Sedan		TP1-L-41	TP1-M-41	TP1-H-41	TP2-L-41	TP2-M-41	TP2-H-41	--
4-Door Hardtop		--	--	--	--	--	TP2-H-43	--
4-Door Sta. Wag., 6-Passenger		TP1-L-45	--	--	TP2-L-45	TP2-M-45	TP2-H-45	--
4-Door Sta. Wag., 9-Passenger		TP1-L-45	--	--	TP2-L-45	TP2-M-45	TP2-H-45	--

# AMA Specifications – Passenger Car

MAKE OF CAR VALIANT-PLYMOUTH MODEL YEAR 1963 DATE ISSUED 8-1-62 REVISED(●) 1-16-63

## GENERAL SPECIFICATIONS

(All dimensions in inches unless otherwise indicated)

MODEL	Additional Information Page No.:	TV1			TPI		TP2			
		Sd. & HT	Conv.	Sta. Wag.	Sd. & HT	Sta. Wag.	Sd & HT	Conv.	Sta. Wag.	
Wheelbase (L101)	23	106.0			116.0					
Tread	Front (W101)	22	55.9			59.5				
	Rear (W102)	22	55.6			57.5				
Maximum Overall Dimensions	Length (L103)	23	186.2		186.8	205.0	210.1	205.0		210.1
	Width (W103)	22	69.8		68.8	75.6	75.1	75.6		75.1 ●
	Height (H101)	24	53.4	54.0	53.1	54.1	54.0	53.9	54.3	54.0
Transmission— (Specify trade name – opt., not available)	Manual	15	Std.							
	Overdrive	16	NA							
	Automatic	16	Opt.: TorqueFlite							
Axle ratio (a)	Manual	17	2.93			3.31	3.23			
	Overdrive	17	--							
	Automatic	17	3.23			2.93	3.23	2.76		
Tire size	18	6.50 x 13				7.00 x 14				
Engine	Type, no. cyl., valve arr.	2	6, in-line, OHV, inclined 30°				90°V-8, OHV			
	Fuel system (Carb., other)	8	Carb., 1-bbl				Carb., 2-bbl			
	Bore and stroke	2	3.400 x 3.125			3.400 x 4.125		3.91 x 3.31		
	Piston displ., cu.in.	2	170			225		318		
	Std. compression ratio	2	8.2				9.0			
	Max. bhp at engine rpm	2	101 @ 4400			145 @ 4000		230 @ 4400		
	Max. torque at rpm	2	155 @ 2400			215 @ 2400		340 @ 2400		

(a) See Pages 3 and 17 for additional rear axle ratio information.

# AMA Specifications—Passenger Car

**MAKE OF CAR** VALIANT-PLYMOUTH **MODEL YEAR** 1963 **DATE ISSUED** 8-1-62 **REVISED** (6)

<b>MODEL</b>	TV1		TP1	TP2		
	Std. 170 cu. in.	Power Pak 225 cu. in.	Std. 225 cu. in.	Std. 318 cu. in.	Commando 361 cu. in.	Golden Command 383 cu. in.

## ENGINE—GENERAL

Type, no. cyls., valve arr.	6, in-line, OHV, inclined 30°			90°V-8, in-line, OHV		
Bore and stroke (nominal)	3.400 x 3.125	3.400 x 4.125	3.91 x 3.31	4.12 x 3.38	4.25 x 3.38	
Piston displacement, cu. in.	170	225	318	361	383	
Bore spacing (C/L to C/L)	1-2, 3-4, 5-6: 3.98; 2-3, 4-5: 4.0			4.46	4.80	
No. system (front to rear)	L. Bank	--			1-3-5-7	
	R. Bank	--			2-4-6-8	
Firing order	1-5-3-6-2-4			1-8-4-3-6-5-7-2		
Compras. ratio (nominal)	8.2			9.0	10.0	
Cylinder Head Material	Cast iron					
Cylinder Block Material	Cast iron	Cast iron(a)	Cast iron			
Cylinder Sleeve—Wet, dry, none	None	None (b)	None			
Number of mounting points	Front	Two				
	Rear	One				
Engine installation angle	1.25° left, 3° up			1.1° right, 2.6° up		
Taxable horsepower <small>Dia.<sup>2</sup> x No. Cyl. 2.5</small>	27.7			48.9	54.3	57.8
Published max. bhp* @ eng. RPM	101 @ 4400	145 @ 4000		230 @ 4400	265 @ 4400	330 @ 4600
Published max. torque* (lb. ft. @ RPM)	155 @ 2400	215 @ 2400		340 @ 2400	380 @ 2400	425 @ 2800
Recommended fuel regular - premium	Regular					Premium
Idle speed (spec. neutral or drive)	Manual	550 in neutral (d)			500 in neutral	
	Automatic	550 in neutral (d)			500 in neutral	

## ENGINE—PISTONS

Material	Aluminum Alloy					
Description and finish	Slipper-type, steel strut, elliptically-turned, tin-plated			(c)	Slipper-type, steel strut, elliptically-turned, tin-plated	
Weight (piston only) oz.	16.4			20.9	25.3	27.1
Clearance (limits)	Top land		.025 - .030	.029 - .034	.032 - .038	
	Skirt	Top Bottom	.0005 - .0015 specified, .00075 - .00125 desired			
Ring groove depth	No. 1 ring		.179	.205	.215	.220
	No. 2 ring		.179	.205	.215	.220
	No. 3 ring		.181	.198	.204	.208
	No. 4 ring		None			

\* Max. bhp (brake horsepower) and max. torque corrected as defined by SAE Engine Test Code.

- (a) Die-cast aluminum block optional.
- (b) With aluminum block, a dry sleeve is used.
- (c) Horizontal slot, steel band, elliptically-turned, tin-plated.
- (d) With alternator charging.

# AMA Specifications – Passenger Car

MAKE OF CAR VALIANT-PLYMOUTH MODEL YEAR 1963 DATE ISSUED 8-3-62 REVISED(•) 1-16-63

## POWER TEAMS

(Indicate whether standard or optional)

MODEL AVAILABILITY		ENGINE					TRANSMISSION		AXLE RATIO (Std. first)
		Displ. cu. in.	Carburetor	Compr. Ratio	BHP @ RPM	Torque @ RPM			
VALIANT	Std.	170	1-bbl	8.2	101 @ 4400	155 @ 2400	Man.	Early Cars	3.23, 3.55, ●
								Later Cars	2.93, 3.23, 3.55, ●
	Opt.	225						Automatic	3.23, 3.55
								Manual	3.23, 3.55, ●
PLYM. 6	Std. All Except Sta. Wag.	225	1-bbl	8.2	145 @ 4000	215 @ 2400		Manual	3.31, 3.55
								Automatic	2.93, 3.31, 3.55
	Std. Sta. Wag.							Manual	3.23, 3.55
								Automatic	3.23, 3.55
PLYMOUTH V-8	Std. All Models	318	2-bbl	9.0	230 @ 4400	340 @ 2400	Man.	Early Cars	3.23, 3.55
								Later Cars	2.93, 3.23, 3.55
								Automatic	2.76, 3.23
	Opt. All Models	361					Man.	3-Speed	3.23
								4-Speed	3.55, 3.23
								Automatic	3.23, 2.76
	383	4-bbl	10.0	330 @ 4600	425 @ 2800	Man.	3-Speed	3.23	
							4-Speed	3.55, 3.23	
							Automatic	3.23, 2.76	

# AMA Specifications – Passenger Car

MAKE OF CAR VALIANT-PLYMOUTH MODEL YEAR 1963 DATE ISSUED 8-1-62 REVISED (\*)

	See page 2 for engine usage			
MODEL	170 cu.in.	225 cu.in.	318 cu.in.	361 cu.in. 383 cu.in.

## ENGINE—RINGS

Function (top to bottom)	No. 1, oil or comp.	Compression		
	No. 2, oil or comp.	Compression		
	No. 3, oil or comp.	Oil		
	No. 4, oil or comp.	None		
Compression	Description - material, type, coating, etc.	Cast iron, low taper and twist, tin-plated	#1: Cast iron, taper twist, tin-plated (a)	Cast iron, standard taper and twist, tin-plated
	Width	.078		
	Gap	.010 - .020		.013 - .025
Oil	Description - material, type, coating, etc.	Cast iron, single piece	(b)	Cast iron, single piece
	Width	.186		
	Gap	.010 - .020		.013 - .025
Expanders	Oil ring only: low tension, hump type			(c)

## ENGINE—PISTON PINS

Material		High manganese steel		
Length		2.965	2.995	3.565
Diameter		.9008	.9842	1.094
Type	Locked in rod, in piston, floating, etc.	Press-fit in rod		Floating
	Bushing	In rod or piston	None	
		Material	Rod	
Clearance		.00025 - .00075	.0000 - .0005	.00035 - .00085
Direction & amount offset in piston		Right .06		Right .09

## ENGINE—CONNECTING RODS

Material		Drop-forged steel		
Weight (oz.)		25.7	27.3	25.6
Length (center to center)		5.71	6.70	6.12
Bearing	Material & Type	Lead-base babbitt on steel, removable, precision		Bi-metal grid
	Overall length	.985		.843
	Clearance (limits)	.0005 - .0015		
	End play	.006 - .012		.009 - .017(2-rods)

- (a) #2: Cast iron, reverse twist, taper-face, lubrite-coated.
- (b) 3-piece; two chrome-plated rails with stainless steel expander-spacer.
- (c) Oil ring only: standard tension, hump type.
- (d) .007 - .0014 interference.

# AMA Specifications—Passenger Car

MAKE OF CAR VALIANT-PLYMOUTH MODEL YEAR 1963 DATE ISSUED 8-1-62 REVISED <sup>(a)</sup>  
 See Page 2 for engine usage

<b>MODEL</b>	170 cu in. 225 cu in.	318 cu in.	361 cu in. 383 cu in.
--------------	--------------------------	------------	--------------------------

## ENGINE—CRANKSHAFT

Material		Drop-forged steel			
Vibration damper type		Non-adhesion, rubber, dynamic			
End thrust taken by bearing (No.)		Three			
Crankshaft end play		.002 - .007			
Main bearing	Material & type	Lead-base babbitt on steel, removable, precision; #3 only - tin-base babbitt on steel.			
	Clearance	.0002 - .0022 specified; .0005 - .0015 desired			
	Journal dia. and bearing overall length	No. 1	2.750 x 1.034	2.500 x .872	2.625 x .944
		No. 2	2.750 x 1.034	2.500 x .872	2.625 x .944
		No. 3	2.750 x 1.254	2.500 x 1.151	2.625 x 1.221
		No. 4	2.750 x 1.034	2.500 x .872	2.625 x .944
		No. 5	--	2.500 x 1.562	2.625 x .944
		No. 6	--		
No. 7		--			
Dir. & amt. cyl. offset		None			
Crankpin journal diameter		2.187	2.125	2.375	

## ENGINE—CAMSHAFT

Location		Right side	Center of "V", above crankshaft		
Material		Hardenable cast iron; oil pump cam and distributor drive gear cast integrally			
Bearings	Material	Lead-base babbitt on steel			
	Number	Four	Five		
Type of Drive	Gear or chain		Chain		
	Crankshaft gear or sprocket material		Malleable cast iron, or Sintered iron (Super-Oilite)		
	Camshaft gear or sprocket material		Cast iron		
	Timing chain	No. of links	50	68	50
		Width	.88	1.02	.88
Pitch		.50	.38	.50	

## ENGINE—VALVE SYSTEM

Hydraulic lifters (Std, opt, NA)		NA		Std.
Valve rotator, type (intake, exhaust)		Low-friction lock on exhaust		
Rocker ratio		1.5		
Operating tappet clearance (Indicate hot or cold)	Intake	.010 Hot	.013 Hot	Hydraulic
	Exhaust	.020 Hot	.021 Hot	Hydraulic
Timing marks on flywheel, damper, other		Stationary indicator on water pump housing	Stationary indicator on chain case cover	

(Continued)

# AMA Specifications—Passenger Car

MAKE OF CAR VALIANT-PLYMOUTH MODEL YEAR 1963 DATE ISSUED 8-1-62 REVISED (\*)

See Page 2 for engine usage

	170 cu in. 225 cu in.	318 cu in.	361 cu in.	383 cu in.
--	--------------------------	------------	------------	------------

## ENGINE—VALVE SYSTEM (cont.)

Timing	Intake	Opens ( <sup>o</sup> BTC)	8	19	13	24
		Closes ( <sup>o</sup> ABC)	44	45	59	64
		Duration - deg.	232	244	252	268
	Exhaust	Opens ( <sup>o</sup> BBC)	48	59	59	64
		Closes ( <sup>o</sup> ATC)	TDC	1	13	24
		Duration - deg.	228	240	252	268
Valve opening overlap		8	20	26	48	
Intake	Material		SAE 1041			
	Overall length		4.77	4.60	4.87	
	Actual overall head dia.		1.62	1.84	2.08	
	Angle of seat & face		47 <sup>o</sup> - 45 <sup>o</sup>		45 <sup>o</sup>	
	Seat insert material		None			
	Stem diameter		.37			
	Stem to guide clearance		.001 - .003			
	Lift (@ zero lash)		.371	.397	.392	.430
	Outer spring press. and length	Valve closed (lb. @ in.)	53 @ 1.69		100 @ 1.86	
		Valve open (lb. @ in.)	143.5 @ 1.31		195 @ 1.47	
	Inner spring press. and length	Valve closed (lb. @ in.)	None			Damper only
		Valve open (lb. @ in.)	None			
	Exhaust	Material		21-4N		
Overall length		4.80	4.54	4.89		
Actual overall head dia.		1.36	1.56	1.60		
Angle of seat & face		45 <sup>o</sup>				
Seat insert material		None				
Stem diameter		.37				
Stem to guide clearance		.002 - .004				
Lift (@ zero lash)		.364	.403	.390	.430	
Outer spring press. and length		Valve closed (lb. @ in.)	53 @ 1.69		100 @ 1.86	
		Valve open (lb. @ in.)	143.5 @ 1.31		195 @ 1.47	
Inner spring press. and length		Valve closed (lb. @ in.)	None			Damper only
		Valve open (lb. @ in.)	None			

## ENGINE—LUBRICATION SYSTEM

Type of lubrication (splash, pressure, nozzle)	Main bearings	Pressure			
	Connecting rods	Pressure			
	Piston pins	Metered jet spray			
	Camshaft bearings	Pressure			
	Tappets	Splash	Pressure		
	Timing gear or chain	Jet			
	Cylinder walls	Metered jet spray			

(Continued)

# AMA Specifications – Passenger Car

<b>MAKE OF CAR</b> VALIANT-PLYMOUTH	<b>MODEL YEAR</b> 1963	<b>DATE ISSUED</b> 8-1-62	<b>REVISED (*)</b> 1-16-63
	TVI	TP1	TP2
<b>MODEL</b>	Std Power Pak	Std	Std Commando Options

## ENGINE—LUBRICATION SYSTEM (cont.)

Oil pump type	Rotary
Normal oil pressure (lb. @ engine rpm)	45 to 65 @ 2000
Oil pressure sending unit (elect. or mech.)	Electrical
Type oil intake (floating, stationary)	Stationary
Oil filter system (full flow, partial, other)	Full flow
Filter replacement (element, complete)	Complete
Capacity of crankcase, less filter-refill (qt.)	4
Oil grade recommended (SAE viscosity and temperature range)	Above +32F . . . . . SAE 30, SAE 10W-30, or SAE 20W-40 As Low as +10F . . . . . SAE 20W or SAE 10W-30 As Low as -10F . . . . . SAE 10W, SAE 10W-30, or SAE 5W-20 Below -10F . . . . . SAE 5W-20
Engine Service Requirement (MM, MS, etc.)	MS

## ENGINE—EXHAUST SYSTEM

Type (single, single with cross-over, dual, other)	Single	Single, with cross-over
Muffler No. & type (reverse flow, straight thru, separate resonator)	One, reverse flow (b) ●	
Exhaust pipe dia. (O.D. & wall thickness)	--	1.75 x .075 ●
	Branch	1.88 x .083 ●
	Main	2.00 x .075 ●
	1.75 x .060	2.25 x .083 ●
Tail pipe diameter (O.D. & wall thickness)	1.50 x .048	1.88 x .048 ●

## ENGINE—CRANKCASE VENTILATION SYSTEM

Type (ventilates to atmos., induction system, other)	Standard	Induction system
	Optional	--
Control unit	Make and model	AC or Chicago Screw (a)
	Location	Cylinder head cover outlet
	Energy source (manifold vacuum, carburetor air stream, other)	Manifold vacuum
	Control method (variable orifice, fixed orifice, other)	Variable orifice
Complete system	Discharges (to Intake manifold, carb. air intake, air cleaner intake, other)	Intake manifold, at or through base of carburetor
	Air inlet (breather cap, carburetor air cleaner, other)	Breather cap
	Flame arrester (screen, check valve, other)	Check valve

(a) Part numbers: for 170 cu in. engine, Chicago Screw - 2406211, AC - 2205957  
 for all other engines, Chicago Screw - 2406212, AC - 2264344

(b) Golden Commando has dual exhausts.



# AMA Specifications— Passenger Car

MAKE OF CAR	VALIANT-PLYMOUTH	MODEL YEAR	1963	DATE ISSUED	8-1-62	REVISED (*)	
		TV1	TP1	TP2			
MODEL		170 cu in.	225 cu in.	225 cu in.	318 cu in.	361 cu in.	383 cu in.

## ENGINE—FUEL SYSTEM

(See Supplement to Page 8 for Details of Fuel Injection, Supercharger, etc. if used)

Induction type: Carburetor, fuel injection, supercharger.		Carburetor					
Fuel Tank	Capacity (gals.)	18		All except Sta. Wag. - 20; Sta. Wag. - 21.5			
	Filler location	Left rear fender		Behind rear license plate (a)			
Fuel Pump	Type (elec. or mech.)	Mechanical					
	Locations	Right center			Right front		
	Pressure range	4 - 5.5 psi		6 - 7.5 psi	4 - 5.5 psi		
Vacuum booster (std., optional, none)		None					
Fuel Filter	Type	Fuel tank - Plastic; Fuel line - Paper					
	Locations	Fuel tank and in line between fuel pump and carburetor					
Carburetor	Choke type	Automatic, separate					
	Intake manifold heat control (exhaust or water)	Exhaust					
	Air clnr. type	Standard	Paper element				
	Optional	--					

(a) Station Wagons: Top of left rear fender.

### CARBURETOR SUPPLEMENTARY INFORMATION

Model Usage	Engine Displ.	Transmission	Carburetors		No. Used and Type	Barrel Size	
			Make	Model			
VALIANT	Std 170	Manual	Ball and Ball	BBS-3462 S	1, 1-bbl	1-9/16	
			Holley	R-2533 A			
		Automatic	Ball and Ball	BBS-3463 S			
			Holley	R-2534 A			
	Opt 225	Manual	Ball and Ball	BBS-3464 S		1, 1-bbl	1-11/16
			Holley	R-2535 A			
Automatic	Ball and Ball	BBS-3465 S					
	Holley	R-2536 A					
PLYMOUTH SIX	Std 225	Manual	Ball and Ball	BBS-3466 S	1, 1-bbl		1-11/16
			Holley	R-2537 A			
		Automatic	Ball and Ball	BBS-3468 S			
			Holley	R-2538 A			
			Stromberg	WA-3-219			
PLYMOUTH V-8	Std 318	Manual	Ball and Ball	BBD-3472 S	1, 2-bbl	1-7/16	
			Stromberg	WW-3-222			
		Automatic	Ball and Ball	BBD-3473 S			
			Stromberg	WW-3-223			
	Opt 361	All	Ball and Ball	BBD-3475 S		1, 4-bbl	1-9/16
	Opt 383	All	Carter	AFB-3437 S			P: 1-7/16 S: 1-9/16

# AMA Specifications – Passenger Car

<b>MAKE OF CAR</b>	VALIANT-PLYMOUTH	<b>MODEL YEAR</b>	1963	<b>DATE ISSUED</b>	8-1-62	<b>REVISED(*)</b>	
<b>MODEL</b>	TV1	TPI	TP2				
	Std.	Power Pak	Std.	Std.	Commando	Golden Commando	

## ENGINE—COOLING SYSTEM

Type system (pressure, pressure vented, atmospheric, other)		Pressure-vent						
Radiator cap relief valve pressure		14; 16 with AC						
Circulation thermostat	Type (choke, bypass)	Choke, pellet						
	Starts to open at (°F)	177 to 182						
Water pump	Type (centrifugal, other)	Centrifugal						
	GPM @ 1000 pump rpm							
	Number of pumps	One						
	Drive (V-belt, other)	V-belt						
Bearing type		Ball, permanently sealed						
By-pass recirculation type (internal, external)		External			Internal			
Radiator core type (cellular, tube and fin, other)		Tube and spacer			Tube and spacer (a)			
Cooling system capacity	With heater (qt.)	12	13	21	17			
	Without heater (qt.)	11	12	20	16			
	Opt. equipment-specify (qt.)	None						
Water jackets full length of cylinder (yes, no)		No			Yes		No	
Water all around cylinder (yes, no)		Yes						
Radiator hose	Lower	Number and type (molded, straight)	One, molded					
		Inside diameter	1.50			Radiator end . . . 1.50 Water pump end . 1.75		
	Upper	Number and type (molded, straight)	One, molded					
		Inside diameter	1.50					
	By-pass	Number and type (molded, straight)	One, straight		One, molded	None		
		Inside diameter	0.68		0.80	--		
Fan	Number of blades & Spacing	Four, 76° - 104° (b)		(c)	Four, 76° - 104° (d)			
	Diameter	16; 17 w/AC		17,18 w/AC	18			
	Ratio-fan to crankshaft rev.	1.07:1, w/AC 1.10:1		1.07:1	.95 : 1	.95 : 1, w/AC 1.35 : 1		
	Fan cutout type	None						
	Bearing type	See water pump						
*Drive belts (Indicate belt used by letter)	Fan	See Page 9A						
	Generator	" " "						
	Water Pump	" " "						
	Power Steering	" " "						
	Air Conditioning	" " "						

- (a) With automatic transmission, a fin and tube radiator is used optionally.
- (b) With air conditioning: six, 54° - 50° - 76°.
- (c) Four, 76° - 104°.
- (d) With air conditioning: seven, 60° - 45° - 59° - 47° - 54° - 50° - 45°.

# AMA Specifications – Passenger Car

MAKE OF CAR VALIANT-PLYMOUTH MODEL YEAR 1963 DATE ISSUED 8-1-62 REVISED (a)

## SUPPLEMENTARY INFORMATION

MODEL \_\_\_\_\_ DRIVE BELTS \_\_\_\_\_

### LEGEND - PULLEY LOCATIONS:

- |                          |                                 |
|--------------------------|---------------------------------|
| CS - Crankshaft Drive    | AC - Air Conditioner Compressor |
| FWP - Fan and Water Pump | PS - Power Steering Pump        |
| A - Alternator           | I - Idler                       |

### APPLICATIONS

	VALIANT				PLYMOUTH SIX			PLYMOUTH V-8					
	170 cu in.		225 cu in.		225 cu in.			318 cu in.		361 cu in.		383 cu in.	
	w/wo PS	AC w/wo PS	w/wo PS	AC w/wo PS	Std.	With PS	AC w/wo PS	w/wo PS	AC w/wo PS	w/wo PS	AC w/wo PS	w/wo PS	AC w/wo PS
CS-FWP-A	A	A	E	E	E	E	E	F	F	H		H	
CS-PS	B	C	B	C		B	C	G	G	I	I	I	I
CS-I-AC-FWP		D		D									
CS-I-AC							D		D				
CS-I-FWP												J	J
CS-AC-A												2K	2K

### DIMENSIONS

	A	B	C	D	E	F	G	H	I	J	K
Angle of "V"	36°										
Nominal Length, SAE	55.00	36.50	38.38	53.00	57.38	48.50	38.75	46.25	41.00	34.25	66.35
Width	.38			.50	.38		.50	.38	.50	.38	.47

MAKE OF CAR	VALIANT-PLYMOUTH				MODEL YEAR	1963	DATE ISSUED	8-1-62	REVISED (•)	1-16-63
MODEL	TV1		TP1		TP2					
	170 cu.in.	225 cu.in.	225 cu.in.	318 cu.in.	361 cu.in.	383 cu.in.				

**ELECTRICAL—SUPPLY SYSTEM**

Battery	Make and Model		Various			
	Voltage Rtg. & Total Plates		12, 42	12, 54		12, 66
	SAE Designation & Amp Hr. Rtg		9HCO, 38	9HC3, 48		9HC3A, 59
	Location		Left front fender shield			
	Terminal grounded		Negative			
Alternator Generator	Make		Chrysler			
	Model		2098835	2098830	2098840 (a)	
	Type		Three phase, full wave rectifier			
	Ratio—Gen. to Cr/s rev.		2.45 to 1	2.18 to 1	2.32 to 1.(b)	
	Gen. cut-in (hot)—engine rpm		Not applicable			
Regulator	Make		Chrysler			
	Model		2098300			
	Type		Voltage only			
	Cutout relay	Closing voltage @ generator rpm	--			
		Reverse current to open	--			
	Regulated	Voltage	13.7 to 14.3 @ 70 F.			
		Current	--			
	Voltage test conditions	Temperature	75 F			
		Load	15-amp			
		Other	Run 15 min. at 1250 engine rpm with 15-amp load			

**ELECTRICAL—STARTING SYSTEM**

Starting motor	Make		Chrysler			
	Model		2098500	1889200 (c)		
	Rotation (drive end view)		Clockwise			
	Engine cranking speed					
	Test conditions					
	Lock test	Amps	340-420	400-450		
		Volts	4			
		Torque (lb. ft.)	NA			
	No load test	Amps, Max.	90			
		Volts	11			
RPM (min.)		2950	1925 - 2400			
Motor control	Switch (solenoid, manual)		Solenoid			
	Starting procedure		With transmission in neutral, depress accelerator pedal one-third, turn ignition key beyond "ignition on" position			

(Continued)

- (a) With 361 cu.in. engine, alternator no. 2098830 is used.
- (b) With air conditioning - 2.44 to 1
- (c) 2095150 with automatic transmission.

# AMA Specifications – Passenger Car

MAKE OF CAR	VALIANT-PLYMOUTH	MODEL YEAR	1963	DATE ISSUED	8-1-62	REVISED (a)	
MODEL	TV1		TV1, TP1	TP2			
	170 cu in.		225	318 cu in.		361	383
	Man.	Auto.	cu in.	Man.	Auto.	cu in.	cu in.

## ELECTRICAL—STARTING SYSTEM (cont.)

Motor Drive	Engagement type		Solenoid, with reduction gear			
	Pinion meshes (front, rear)		Front			
	Number of teeth	Pinion	10		10 (a)	
		Flywheel	122	130	130 (a)	
Flywheel tooth face width						

## ELECTRICAL—IGNITION SYSTEM

Coil	Make		Autolite or Essex, with Chrysler-ballast resistor						
	Model		200567 or 62-160-2						
	Amps	Engine stopped	3.0						
Engine idling		1.9							
Distributor	Make		Chrysler				Autolite		
	Model		2098665	2098675	2098670	2098680	2098685	2095836	IBS-4006 G
	Cent'fgal adv. in crankshaft degrees @ engine rpm (nominal)	Start (rpm)	See Page 11 A						
		Intermediate points deg. @ rpm	--						
		Max deg. @ rpm	--						
	Vacuum adv. in crankshaft degrees @ in. Hg. (nominal)	Start (in Hg)	See Page 11 A						
		Intermediate points, deg @ in Hg	--						
		Max. deg. in. Hg.	--						
	Breaker gap (in.)		.017 to .023			.014 to .019			
	Cam angle (deg.)		40 to 45			28 to 33		(b)	
Breaker arm tension (oz.)		17 to 20			17 to 21.5				
Timing	Crankshaft deg. @ rpm.		2.5 BTC @ 500		(c)	10 BTC @ 500			
	Mark location		Water pump housing			Chain case cover			
	Cylinder numbering system (see page 2)		Front to rear			Left: 1 - 3 - 5 - 7 Right: 2 - 4 - 6 - 8			
	Firing order (see page 2)		1 - 5 - 3 - 6 - 2 - 4			1 - 8 - 4 - 3 - 6 - 5 - 7 - 2			
Spark Plug	Make and model		Champion N-14Y		Champion J-12Y		Champion J-9Y		
	Thread (mm)		14-mm						
	Tightening torque (lb. ft.)		30 to 32						
	Gap		.035						
Cable	Conductor type		Resistor						
	Insulation type		Synthetic rubber with neoprene jacket						
	Spark plug protector		Hypalon			Silicone			

## ELECTRICAL—SUPPRESSION

Locations & type	Resistance-type leads to coil and spark plugs
------------------	---

- (a) With manual transmission; pinion 9, gear 172.
- (b) Dual: each set 27 to 32, both sets 34 to 40.
- (c) 5 BTC @ 500.

MAKE OF CAR VALIANT-PLYMOUTH MODEL YEAR 1963 DATE ISSUED 8-1-62 REVISED (\*)

## SUPPLEMENTARY INFORMATION

MODEL

DISTRIBUTOR

### CENTRIFUGAL ADVANCE - Crankshaft degrees at engine rpm

	IBS - 4006G	2095836	2098665	2098670
Start	0 @ 550 - 850	0 @ 500 - 900	0 @ 750 - 1050	0 @ 780 - 1120
Intermediate	0 - 6 @ 850 14 - 18 @ 1550	0 - 4 @ 900 5 - 9 @ 1400	0 - 5 @ 1050 16 - 20 @ 2020	0 - 4 @ 1120 12 - 16 @ 2160
Maximum	22 - 26 @ 4100	21 - 25 @ 4300	25 - 29 @ 4400	21 - 25 @ 5000

	2098675	2098680	2098685
Start	0 @ 650 - 950	0 @ 650 - 950	0 @ 660 - 1140
Intermediate	0 - 16 @ 950 14 - 18 @ 1220	0 - 4 @ 950 11 - 15 @ 1700	0 - 4 @ 1140 7 - 11 @ 2000
Maximum	25 - 29 @ 4400	17 - 21 @ 4000	15 - 19 @ 5200

### VACUUM ADVANCE - Crankshaft degrees at inches of mercury

	IBS - 4006G	2095836	2098665	2098670
Start	0 @ 7.5 - 9.2	0 @ 4.5 - 8	0 @ 5 - 7.1	0 @ 4.9 - 7.1
Intermediate	9 - 15 @ 12	12 - 18 @ 12	6 - 12 @ 8.5	6 - 10 @ 10.5
Maximum	19 - 25 @ 16	23 - 29 @ 16.5	12 - 17 @ 10	21 - 25 @ 13

	2098675	2098680	2098685
Start	0 @ 5 - 7.1	0 @ 8 - 10	0 @ 8 - 10
Intermediate	6 - 12 @ 8.5	10 - 16 @ 13	10 - 16 @ 13
Maximum	12 - 17 @ 10	17 - 23 @ 15.5	17 - 23 @ 15.5

# AMA Specifications – Passenger Car

<b>MAKE OF CAR</b> <u>VALIANT-PLYMOUTH</u>	<b>MODEL YEAR</b> <u>1963</u>	<b>DATE ISSUED</b> <u>8-8-62</u>	<b>REVISED</b> <u>(*)</u>
<b>MODEL</b>	<u>TV1</u>	<u>TP1, TP2</u>	

## ELECTRICAL—INSTRUMENTS AND SWITCHES

<b>Speed-ometer</b>	<b>Make</b>	Stewart-Warner	King Seely
	<b>Trip odometer (yes, no)</b>	No	
<b>Charge Indicator—type</b>		Ammeter	
<b>Temperature Indicator—type</b>		Electric, Thermal	
<b>Oil pressure Indicator—type</b>		Light	
<b>Fuel indicator—type</b>		Electric, Thermal	
<b>Other</b>		None	
<b>Ignition switch</b>	<b>Identify positions in order and circuits controlled</b>	Center position . . . . . Off 1st position clockwise . . . . . Ignition and accessory circuit only 2nd position clockwise . . . . . Starter and ignition circuit only 1st position counterclockwise . . . . . Accessory circuit only	
	<b>Provision for illumination</b>	Stray	None
	<b>Location</b>	Right of steering column	
<b>Main lighting switch</b>	<b>Identify positions and lamps controlled</b>	Full in . . . . . Off 1st position out . . . . . Instruments, tail, parking, and license plate lamps Full out . . . . . Instruments, tail, head, and license plate lamps	
	<b>Locations and lamps controlled</b>	INSTRUMENT LAMPS: Variable rheostat, concentric with head lamp switch. OIL PRESSURE SWITCH: Engine. DOME LAMP: Integral with head lamp switch. AUTOMATIC DOOR SWITCH: Both front doors. STOP LAMP SWITCH: Brake pedal. DIRECTIONAL SIGNAL SWITCH: Lever on steering column below steering wheel.	
<b>Other light switches</b>	<b>Locations and devices controlled</b>	Windshield wiper - One-speed, left of steering column. (Variable-speed, optional.) Defroster control - Push button, right of steering column. Air Vent - Push button, right of steering column.	
	<b>Other switches</b>	Heater control: Two-speed by push buttons, right of steering column.	Heater Control: Rotary, 3-speed right of steering column.
<b>Windshield wiper</b>	<b>Make</b>	General Industries or Autolite (motor only)	
	<b>Type</b>	Electric	
	<b>Vacuum booster provision</b>	None	
	<b>Washer provision</b>	Yes, Opt.	
<b>Horn</b>	<b>Type</b>	Sea Shell	
	<b>Number used</b>	Two	
	<b>Amp draw (each)</b>	Spartan Automotive: 6 - 8 amp; Autolite: 8 - 10 amp	

# AMA Specifications – Passenger Car

MAKE OF CAR VALIANT-PLYMOUTH MODEL YEAR 1963 DATE ISSUED 8-1-62 REVISED <sup>(e)</sup>

<b>MODEL</b>	TV1	TP1, TP2
--------------	-----	----------

## ELECTRICAL—LAMP BULBS

Give quantity used and trade number, e.g., Headlamp 2-5400 S, dual headlight 2-4001, 2-4002.  
Indicate accessories which are not standard equipment by an asterisk following the numbers.

Headlamps & arrangement	2-6012	Hi-beam 2-4001, Lo-beam 2-4002
Headlamp beam indicator		1 - 57
Parking		2 - 1034 (A)
Tail		2 - 1034 (B)
Stop		Same as (B)
Direction signal	Front	Same as (A)
	Rear	Same as (B)
	Indicator	1 - 57
License plate	1 - 67	2 - 67
Instrument	3 - 57	5 - 57 (C)
Ignition lock		NA
Back up		2 - 1073*
Dome		1 - 1004
Clock	NA	Same as (C)
Radio	1 - 53X *	1 - 1892 or 1893 *
Glove compartment	1 - 1891 * (a)	1 - 1891 *
Trunk		1 - 1003 * (a)
Underhood	1 - 1003 * (a)	1 - 1003 *
Trans. Push Buttons	1 - 53X *	Same as (C)
Parking Brake Indicator		1 - 57 *
Map and Courtesy		1 - 90 * (b)
Heater Push Buttons	NA	Same as (C)
Oil Pressure Indicator		1 - 57

(a) Dealer installed only.

(b) Standard on convertible coupe, dealer installed only on other models.



# AMA Specifications – Passenger Car

MAKE OF CAR VALIANT-PLYMOUTH MODEL YEAR 1963 DATE ISSUED 8-14-62 REVISED (a)

	TV1		TP1		TP2	
	Exc. Sta. Wag.	Sta. Wag.	Exc. Sta. Wag.	Sta. Wag.	Exc. Sta. Wag.	Sta. Wag.

MODEL \_\_\_\_\_

## ELECTRICAL—FUSE & CIRCUIT BREAKER DATA

Use trade number of fuse, e.g., SFE-10. Indicate circuit breaker by ampere capacity suffixed by letters "C.B.", e.g., 30 C.B. Where fuse or circuit breaker protects multiple circuits indicate first use by a letter and repeat the same letter for all units protected by the same fuse or circuit breaker, e.g., Parking lamp SFE-10 (a), Direction indicator same as (a).

Headlamp	15 CB (A)
Headlamp beam indicator	Same as (A)
Parking lamp	AGC 15 (B)
Tail lamp	Same as (B)
Stop lamp	Same as (B)
Direction indicator	Same as (B)
License plate lamp	Same as (B)
Instrument lamp	AGC 2 (C)
Ignition lamp	None
Back up lamp	Same as windshield wiper
Dome lamp	Same as (B)
Clock	Same as (C)
Clock lamp	Same as (C)
Radio	AGC 7.5
Glove compartment lamp	AGC 20 (D)
Trunk	Same as (B)
Under Hood	Same as (B)
Parking Brake Indicator	Same as (B)
Cigar Lighter	Same as (D)
Heater	AGC 20 (E)
Air Conditioner	Same as (E)
Oil Pressure Indicator	Same as (C)
Windshield Wiper	Single-speed, 5 CB, Variable-speed, 6 CB

## ELECTRICAL—LOCATION OF OUTSIDE LAMPS

		Lowest	21.3	19.2	22.9	24.6	22.6	24.6	
		Highest	--						
Height above ground to center of bulb	Stop		21.3	19.2	22.9	24.6	22.6	24.6	
	Backup		21.4	19.6	20.5	13.2	20.2	13.2	
	License, rear		17.6	15.0	25.5	13.6	25.2	13.6	
	Directional	Front		13.2	13.8	25.6	26.2	25.5	26.1
		Rear		21.3	19.2	22.9	24.6	22.6	24.6
	Headlamp	Inside		--		24.2	24.8	24.1	24.7
		Outside*		23.8	24.4	24.2	24.8	24.1	24.7
	Distance from C/L of car to center of bulb	Tail	Inside	--					
Outside			23.5	30.0	32.2	30.3	32.2	30.3	
Stop			23.5	30.0	32.2	30.3	32.2	30.3	
Backup			9.8	26.6	7.9				
License, rear			On centerline		4.7	9.1	4.7	9.1	
Directional		Front		25.5		32.9			
		Rear		23.5	30.0	32.2	30.3	32.2	30.3
Headlamp		Inside		--		18.2			
	Outside*		28.0		25.1				

\* If single headlamps are used enter here.

# AMA Specifications – Passenger Car

MAKE OF CAR	VALIANT-PLYMOUTH		MODEL YEAR	1963	DATE ISSUED	8-8-62	REVISED (e)	
MODEL	TV1		TP1	TP2				
	170 cu in.	225 cu in.	225 cu in.	318 cu in.	361 cu in. 2-bbl	383 cu in. 4-bbl		

## DRIVE UNITS—CLUTCH (Manual Transmission)

Make & type	Borg and Beck or Auburn, dry plate		Borg and Beck, dry plate, semi-centrifugal		
Type pressure plate springs	Coil				
Effective plate pressure (lb.)	1158 (a)	1445 (b)	1640	2350	
No. of clutch driven discs	One				
Clutch facing	Material Woven asbestos				
	Outside & inside dia.	9.12x6.12	9.25 x 6.0	10.0x6.75	10.5 x 6.5
	Total eff. area (sq.in.)	71.9	77.8	85.5	106.8
	Thickness	B & B .125, Auburn .114			.125
	Engagement cushioning method	Flat wave springs			
Release bearing	Type & method of lubrication Ball bearing, permanently lubricated				
Torsional damping	Methods: springs, friction material Coil springs and friction washers				

## DRIVE UNITS—TRANSMISSIONS

Manual (std. or opt.)	Std.	3-Speed - Std., 4-Speed - Opt.
Manual with overdrive (std. or opt.)	NA	
Automatic (std. or opt.)	Opt.	

## DRIVE UNITS—MANUAL TRANSMISSION

Number of forward speeds	Three		Std. - 3-Speed; Opt. - 4-Speed							
Transmission ratios	In first		See chart below							
	In second		"							
	In third		"							
	In fourth		"							
	In reverse		"							
Synchronous meshing, specify gears	"									
Shift lever location	Steering column									
Lubricant	Capacity (pt.)		5		4.5					
	Type recommended		Automatic Transmission Fluid, Type "A", Suffix "A" (c)							
	SAE viscosity number	Summer	(c)							
		Winter	--							
	Extreme cold		--							
Transmission ratios			3-Speed			4-Speed		3-Speed		4-Speed
			TV1		TP1	TP2				
			170 cu in.		225 cu in.	225 cu in.		318 cu in.		361 cu in.
			(d)		(e)		(d)		(e)	
			2.95		3.22	2.95		2.55		3.02
			1.83		1.82		1.83		1.49	
			1.76		1.92		1.51		1.00	
		1.31		1.00		1.00		1.00		
		3.80		4.15		3.80		3.34		
		2.66		2.61		3.34		2.26		
Synchronous meshing, specify gears	All forward speeds									

Effective plate pressures for Auburn clutch: (a) 1115, (b) 1375.  
 (c) Multipurpose Gear Lubricant SAE 90 or SAE 140 may be used in warm climates.  
 (d) Early-built cars. (e) Later-built cars.



# AMA Specifications – Passenger Car

<b>MAKE OF CAR</b>	VALIANT- PLYMOUTH	<b>MODEL YEAR</b>	1963	<b>DATE ISSUED</b>	8-1-62	<b>REVISED (e)</b>	
		TV1	TP1	TP1	TP2	TP2	
<b>MODEL</b>		170 cu. in.	225 cu. in.	225 cu. in.	318 cu. in.	361 cu. in.	383 cu. in.

## DRIVE UNITS—PROPELLER SHAFT (cont.)

<b>Inter- mediate bearing</b>	Type (plain, anti-friction)						
	Lubrication (fitting, prepack)						
<b>Universal joints</b>	Make						Own
	Number used						Two
	Type (ball and trunnion, cross, other)						Front: Ball and trunnion Rear: Cross and roller
	Bearing	Type (plain, anti-friction)					
Lubric. (fitting, prepack)							Prepack
Drive taken through (torque tube or arms, springs)							Rear springs
Torque taken through (torque tube or arms, springs)							Rear springs

## DRIVE UNITS—REAR AXLE

Description (see instructions)							
Limited Slip differential, type		One-piece case					Std.: One-piece case Opt.: Sure-Grip; two-piece case
Drive Pinion Offset		--					Torque bias
No. of differential pinions		1.625					1.50
<b>Gear ratios (Std. equip.)</b>	Manual transmission	2					Std.: 2; Opt.: Sure-Grip, 4
	Overdrive transmission	2.93 (a)	3.23	3.31 (b)			3.23
	Automatic transmission	3.23	2.93	2.93 (b)	2.76		3.23
Ring gear O.D. (std. ratio)		7.25		8.25 (c)			8.75
Pinion adjustment (shim, other)							Solid shim (washer)
Pinion bearing adj. (shim, other)							Shim pack
Wheel bearing type							Ball bearing
<b>Lubricant</b>	Capacity (pt.)						Taper roller bearing
	Type recommended	2.0					4.0
	SAE vis- cosity number	Summer	Multipurpose gear lubricant, API service GL-4 (d)				
		Winter	Above -10°F: SAE 90				
Extreme cold		Between -10°F and -30°F: SAE 80					
		Below -30°F: SAE 75					

## REAR AXLE RATIO TOOTH COMBINATIONS

(See page 3 for axle ratio usage)

<b>Axle ratio</b>						
	2.76	2.93	3.23	3.31	3.55	3.91
<b>No. of teeth</b>	Pinion	17	14	13	13	11
	Ring gear	47	41	42	43	39

(a) Performance ratio: 3.23.  
(b) Station wagons: 3.23.

(c) Station wagons: 8.75.  
(d) MoPar hypoid lubricant used with Sure-Grip differential.

# AMA Specifications – Passenger Car

MAKE OF CAR	VALIANT-PLYMOUTH	MODEL YEAR	1963	DATE ISSUED	8-8-62	REVISED (*)	1-16-63
MODEL	TV1	TP1		TP2			
		Sd & HT	Sta Wag	Std.		Opt.	
				Exc Wag	Sta Wag	361, 2-bbl	383, 4-bbl

### DRIVE UNITS—WHEELS

Type & material		Disc, steel						
Rim (size and flange type)	Std.	4.5 J	5.0 K	5.5 K	5.0 K	5.5 K		
	Opt.	--	5.5 K	--	5.5 K	--	5.5 K	
Attachment	Type (bolt or stud)	Stud						
	Circle diameter	4						4.5
	Number and size	Five, (a)		Five, 1/2 - 20 NF				

### DRIVE UNITS—TIRES

Standard (List option below)	Size & ply	6.50x13, 2	7.00x14, 2	7.00x14, 4	7.00x14, 2	7.00 x 14, 4	7.00 x 14, 2 ●	
	Type - Nylon, etc.	Rayon						
Rev/mile at 50 mph.		847					803	
Inflation press.(cold)	Front	24						
	Rear	24	22	26 (b)	22	26 (b)	22	
Optional tires - size and ply		--						7.50 x 14, 4

### BRAKES—SERVICE

Type (duo-servo, disc, balanced, etc.)		Duo-servo		
Self adjusting (std., opt., N.A.)		Opt. (c)(h)	Std.	
Hydraulic system type (single, dual, etc.)		Single		
Power brake make & type (remote, integral, etc.)		Integral, pedal-assist, vacuum operated		
Effective area (sq. in.)*		153.5	195.2	195.2 (e)
Gross lining area (sq. in.)**		153.5	195.2	195.2 (e)
Swept drum area (sq. in.)***		254.5	314.2	314.2 (e)
Percent brake effectiveness—front		60		
Drum	Diameter	Front 9	10	10 (d)
		Rear 9	10	10 (d)
Type and material		Cast iron, centrifuse or cast composite		
Wheel cylinder bore	Front	1.00	1.125	●
	Rear	.8125	.9375	●
Master cylinder bore		1.00		
Available pedal travel		6.2 (f)	Std. brakes 7.1; Power brakes 4.8	
Line pressure at 100 lb. pedal load		930 (g)	Std. brakes 860; Power brakes 1100 ●	
Shoe clearance adjustment		No major adjustment required		

(Continued)

\* Excludes rivet holes, grooves, chamfers, etc.

\*\* Includes rivet holes, grooves, chamfers, etc.

\*\*\* Total swept areas for four brakes:

Widest lining contact width for each brake x its drum circumference.

- (a) 7/16 - 20 NF.    (b) 28 lb when fully loaded.    (c) Dealer installed.    (d) Opt.: 11-inch.
- (e) With opt. brakes, effective and gross lining areas are 234.1 sq in.; swept drum area is 380.1 sq in.
- (f) 4.6 with power brakes.    (g) 1080 with power brakes.
- (h) Standard for later-built cars.

# AMA Specifications—Passenger Car

MAKE OF CAR	VALIANT-PLYMOUTH	MODEL YEAR	1963	DATE ISSUED	8-8-62	REVISED (e)	1-16-63
MODEL	TV1	TPI		TP2			
		Sd & HT	Sta Wag	Standard	Optional		
				Exc Wag	Sta Wag	361, 2-bbl	383, 4-bbl

## BRAKES—SERVICE (cont.)

		Bonded or riveted		Bonded				
		Material		Molded asbestos				
Brake lining	Front Shoe	Size (length x width x thickness)	Front wheel	7.66 x 2.25 x .19	8.46 x 2.5 x .19	8.46 x 2.5 x .19 (a)		
			Rear wheel	7.66 x 2.0 x .19	8.46 x 2.5 x .19	8.46 x 2.5 x .19 (b)		
		Segments per shoe		One				
		Material		Molded asbestos				
	Rear Shoe	Size (length x width x thickness)	Front wheel	9.82 x 2.25 x .19	11.06 x 2.5 x .19		11.06 x 2.5 x .19 (e)	
			Rear wheel	9.82 x 2.0 x .19	11.06 x 2.5 x .19		11.06 x 2.5 x .19 (d)	
Segments per shoe		One						
Material		Molded asbestos						

## BRAKES—PARKING

Type of control	(c)	Foot-operated pedal, hand-release lever
Location of control	(f)	Through left end of instrument panel
Operates on	Rear wheels	
If separate from service brakes	Type (internal or external)	--
	Drum diameter	--
	Lining size (length x width x thickness)	--

## FRAME or UNITIZED CONSTRUCTION

Type and description	Unit construction
----------------------	-------------------

## SUSPENSION—GENERAL (See Supplemental page 19 for details on Air Suspension)\*

Provision for car leveling	Manual adjustment at torsion bar anchor bolt	
Provision for brake dip control	By inclined upper control arms and asymmetrical rear springs	
Provision for acc. squat control	Asymmetrical rear springs	
Special provisions for car jacking	None	
Shock absorber front & rear	Type	Direct
	Make	Own
	Piston dia.	1.0
Other special features	--	

## SUSPENSION—FRONT

Type and description	Independent, lateral, non-parallel control arms with torsion bars
----------------------	---

(Continued)

- |  |   |
|--|---|
| (a) With optional brakes: 9.31 x 2.5 x .21 | (d) With optional brakes: 11.97 x 2.5 x .21 |
| (b) With optional brakes: 9.31 x 2.5 x .20 | (e) With optional brakes: 11.97 x 3.0 x .21 |
| (c) T-Handle.                              | (f) Under left end of instrument panel.     |

# AMA Specifications – Passenger Cars

MAKE OF CAR VALIANT-PLYMOUTH MODEL YEAR 1963 DATE ISSUED 8-1-62 REVISED (\*)

	TV1	TP1		
MODEL		Exc. st. wg.	st. wg.	TP2

## SUSPENSION FRONT (cont.)

Spring	Type	Torsion bar		
	Material	Chromium alloy steel		
	Size (coil design height & I.D.; bar length x dia.)	35.8" x 0.83"	41.0" x 0.86"	41.0" x 0.88"
	Spring rate (lb. per in.)	NA		
	Rate at wheel (lb. per in.) (a)	90		100
	Design load (lb. @ design height)	NA		
Stabilizer	Type (link, linkless, frameless)	None		
	Material & bar diameter	--		

## STEERING

Mechanical (std., opt., NA)		Std.	
Power (std., opt., NA)		Opt.	
Wheel diameter		16.0 x 16.4 oval      16.0 x 17.0 oval	
Turning diameter, ft.	Outside front	Wall to wall (l. & r.)	39.8      43.8
		Curb to curb (l. & r.)	37.3      40.8
	Inside rear	Wall to wall (l. & r.)	21.6      23.9
		Curb to curb (l. & r.)	22.2      24.7
Outside wheel angle with inside wheel at 20°		17.6°      18.0°	

Mechanical	Gear	Type	Worm and ball nut		
		Make	Own		
		Ratios	Gear	24.0 to 1	
			Overall	28.7 to 1	
No. wheel turns		5.3			
Power	Gear	Type	Integral		
		Make	Own		
		Trade name	Constant-Control		
	Ratios	Type	Rack and sector		
		Gear	15.7 to 1		
		Overall	18.8 to 1		
	Pump driven by		Belt from crankshaft pulley		
	Number wheel turns		3.5		
Linkage	Type		Trailing, parallel idler arms with equal length tie rods		
	Location (front or rear of wheels, other)		Rear		
	Drag link (trans. or longit.)		Transverse center link		
	Tie rods (one or two)		Two		

(a) includes tires

(Continued)

# AMA Specifications – Passenger Car

MAKE OF CAR	VALIANT-PLYMOUTH	MODEL YEAR	1963	DATE ISSUED	8-1-62	REVISED (e)
MODEL	TV1		TP1		TP2	
	Except Sta. Wag.	Station Wagon	Except Sta. Wag.	Station Wagon	Except Sta. Wag.	Station Wagon

## STEERING (cont)

Steering Axis	Inclination at camber (deg.)		7.5° @ 0° Camber			
	Bearings (type)	Upper	Ball joint			
		Lower	Ball joint			
		Thrust	Oil impregnated sintered metal			
Wheel alignment (range and preferred)	Caster (deg.)		Manual Steering: -0.5° ± 0.5° Power Steering: +0.75° ± 0.5° (a)			
	Camber (deg.)		Left: +0.5° ± 0.25°, Preferred +0.5° Right: +0.25° ± 0.25°, Preferred +0.25°			
	Toe-in (outside tread-inches)		3/32" to 5/32", 1/8" Preferred			
Steering spindle & joint type			Ball socket			
Wheel spindle	Diameter in.	Inner bearing	1.062		1.249	
		Outer bearing	0.687		0.749	
	Thread size		11/16 - 24 NEF		3/4 - 16 UNF	
	Bearing type		Tapered Roller			

## SUSPENSION—REAR

Type and description			Parallel, longitudinal leaf					
Drive and torq. taken through (see page 17)			Rear springs					
Spring	Type		Semi-elliptical, asymmetric					
	Material		Steel					
	Size (length x width, coil design height and I.D.; bar length & dia.)		55" x 2.50"					
	Spring rate (lb. per in.)		85	110	90	115	90	115
	Rate at wheel (lb. per in.)		105 (b)	120 (b)	110 (b)	140 (b)	110 (b)	140 (b)
	Design load (lb. at design height)		(c)					
	Mounting insulation type		Rubber					
	If leaf	No. of leaves	Number	4	5	5	6	5 (d)
Inserts			4, 3.50"	5, 3.50"	5, 3.50"	7, 3.50"	5, 3.50"	7, 3.50"
Material		Plastic		Wax-impregnated fabric (e)				
	Shackle (comp. or tens.)		Compression					
Stabilizer	Type (link, linkless, frameless)		None					
	Material		--					
Track bar type			None					

(a) Maximum differential 0.75°; driver's side less positive.

(b) Includes tires.

(c) Design load, lb @ -.38".

Left	560	760	590*	880	620**	920
Right	530	720	590*	840	620**	880

\* Two-door models; 620 for four-door models.

\*\* 650 for 27 and 43, also for 21, 23, 41 with 361 or 383, cu in. engine; 720 with 413 cu in. engine.

(d) 6 with 361 or 383 cu in. engine; 7 with 413 cu in. engine.

(e) For 7-leaf springs: plastic front, wax-impregnated rear.



MAKE OF CAR VALIANT-PLYMOUTH MODEL YEAR 1963 DATE ISSUED 8-8-62 REVISED (a)

## CAR AND BODY DIMENSIONS—GENERAL

NOTE: Included in the dimension definitions listed on pages 34-36 are those which have been adopted by SAE. These are indicated by a number following the type of dimension, e.g., L3. Additional dimensions have been added by the AMA Specifications Review Committee. These are shown by an additional letter, e.g., H67a. The symbol "a" has been added as a suffix to denote a dimension adopted by the AMA and submitted to the SAE for approval. The dimensions are developed from the following basic points:

1. Body dimensions are for all body styles.
2. All interior dimensions are taken with manikin 15.0 inches outboard of car centerline unless otherwise stated.
3. All interior dimensions are measured with the front seat in the lowest and rearmost position.
4. Unless otherwise specified, all exterior height dimensions are taken with a full design load which consists of 5 passengers, 300 lbs. front, 450 lbs. rear; includes spare wheel, tire and tools, and full complement of gas, oil, water and tires to recommended pressure, etc.
5. The SAE manikin with 90th percentile leg length will be used for recording purposes.
6. The H Point is the pivot center of the manikin's torso and thigh.
7. The Torso Line is a line parallel to the small of manikin's back and extending through the H Point.

## EXTERIOR WIDTH DIMENSIONS

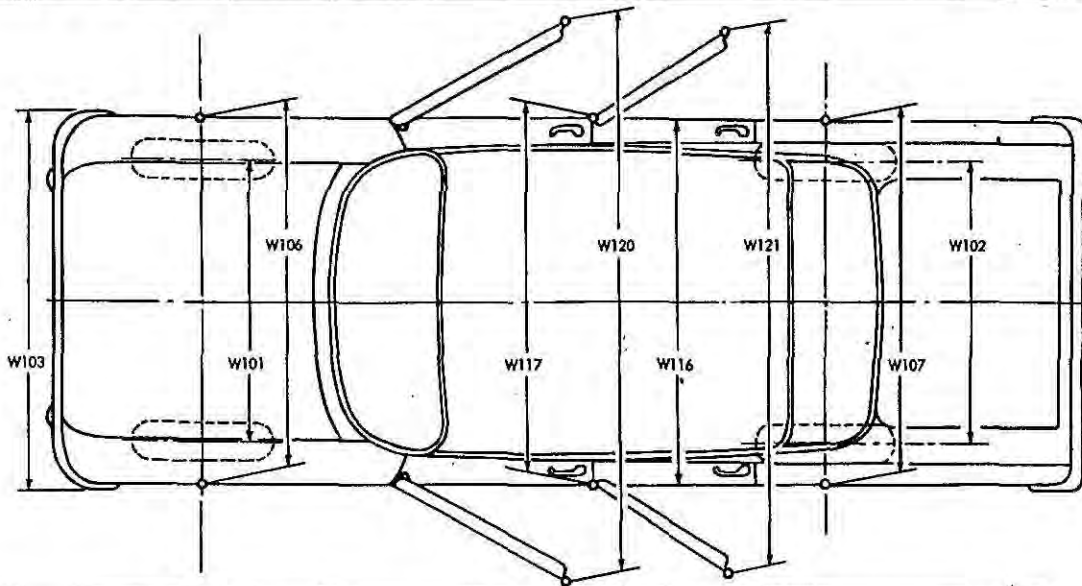

MODEL	Ref. No.	TV1		TP1, TP2		
		2DSd, 2DHT, Conv. Cpe	4-Dr. Sd	Sta. Wag	2DSd, 2DHT, Conv. Cpe	4-Dr. Sd, 4-Dr. HT
Tread - front	W101	55.9		59.5		
Tread - rear	W102	55.6		57.5		
Maximum overall car width	W103	69.8 at rear fender		68.8 (a)	75.6 Over rear bumper	
Maximum overall body width	W116	67.7		68.8	74.8	
Maximum body width at #2 pillar	W117	67.9		73.2		
Front fender overall width	W106	69.0		74.8		
Rear fender overall width	W107	69.8	68.8	74.8		74.6
Maximum overall car width - front doors open	W120a	150.5	139.2		159.2	142.2
Maximum overall car width - rear doors open	W121a	--	127.5		--	139.5

(a) Over rear bumper.

# AMA Specifications – Passenger Car

MAKE OF CAR VALIANT-PLYMOUTH MODEL YEAR 1963 DATE ISSUED 8-8-62 REVISED(•) \_\_\_\_\_

## EXTERIOR LENGTH DIMENSIONS

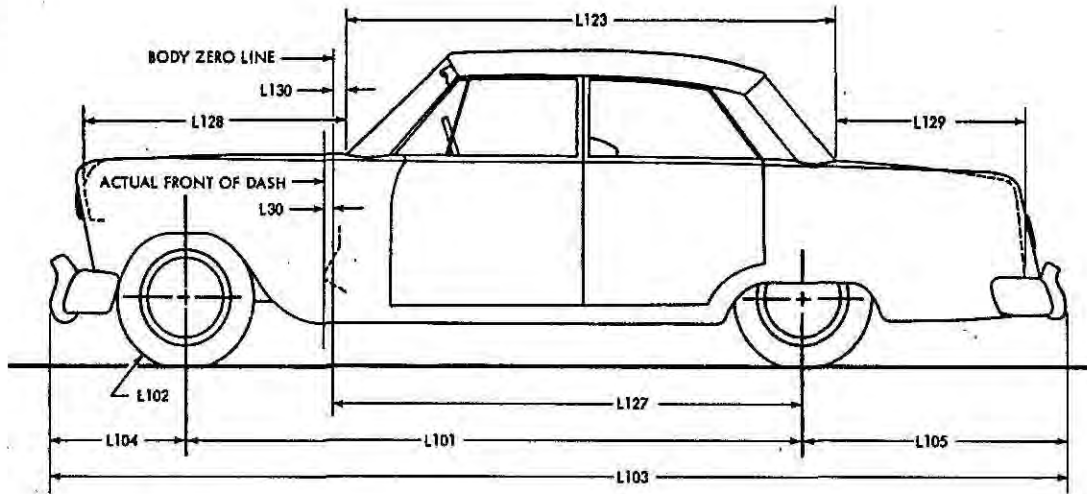

MODEL	Ref. No.	TV1		TP1, TP2	
		Exc. Sta. Wag.	Sta. Wag.	Exc. Sta. Wag.	Sta. Wag.
Body zero line to actual front of dash	L30	1.54		2.0	
Wheelbase	L101	106.0		116.0	
Overhang - front	L104	31.0		34.6	
Overhang - rear	L105	49.2	49.8	54.4	59.5
Overall length	L103	186.2	186.8	205.0	210.1
Hood length at car centerline	L128 <sub>a</sub>	44.5		53.6	
Body upper structure length at car centerline	L123	96.8	--	99.2	--
Deck length at car centerline	L129 <sub>a</sub>	31.1	--	39.4	--
Body zero line to centerline of rear wheels	L127	94.2		99.5	
Body zero line to windshield cowl point	L130 <sub>a</sub>	11.2		10.2	
Tire size	L102	6.50 x 13, 2-ply		7.00 x 14	
				2-ply	4-ply

# AMA Specifications— Passenger Car

MAKE OF CAR VALIANT-PLYMOUTH MODEL YEAR 1963 DATE ISSUED 8-10-62 REVISED (e)

## EXTERIOR HEIGHT DIMENSIONS

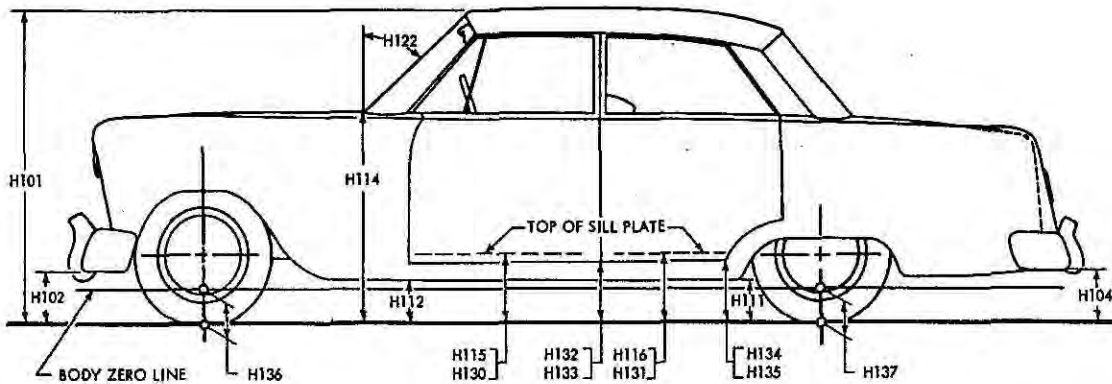

MODEL	Ref. No.	TV1			TP1		TP2		
		Sd & HT	Cv Cpe	Sta Wag	Sd & HT	Sta Wag	Sd & HT	Cv Cpe	Sta Wag
Overall height	H101	53.4	54.0	53.1	54.1	54.0	53.9	54.3	54.0
Hood at rear to ground	H114	36.8		37.0	37.7	38.0	37.6		37.9
Rocker panel to ground - front	H112a	7.4		7.5	8.2	8.4	8.0		8.3
Rocker panel to ground - rear	H111	7.0		6.4	7.7	7.3	7.5		7.2
Step height - front (design load)	H115	12.5		12.6	12.4	12.6	12.3		12.6
Step height - rear (design load)	H116	12.1		11.5	12.3	12.0	12.1		12.0
Step height - front (curb load)	H130	14.3		14.5	14.4	14.5	14.2		14.5
Step height - rear (curb load)	H131	14.7		15.0	14.4	14.7	14.2		14.6
Bottom of door to ground, open - front	H132								
Bottom of door to ground, closed - front	H133	11.7		11.4	11.8	11.6	11.5	11.6	
Bottom of door to ground, open - rear	H134								
Bottom of door to ground, closed - rear	H135	11.6	--	11.1	11.6	11.2	11.4	--	11.1
Front bumper to ground	H102	15.3		16.0	14.4	15.4	14.5		15.3
Rear bumper to ground	H104	15.1		12.4	11.6	9.5	11.5		9.6
Windshield slope angle	H122	53°				57.2°			
Body zero to ground - front	H136a	11.73		12.08	12.57	12.97	12.42		12.90
Body zero to ground - rear	H137a	11.11		10.41	11.72	11.13	11.48		11.12

# AMA Specifications—Passenger Car

MAKE OF CAR VALIANT-PLYMOUTH MODEL YEAR 1963 DATE ISSUED 8-10-62 REVISED(\*)

## GROUND CLEARANCE DIMENSIONS

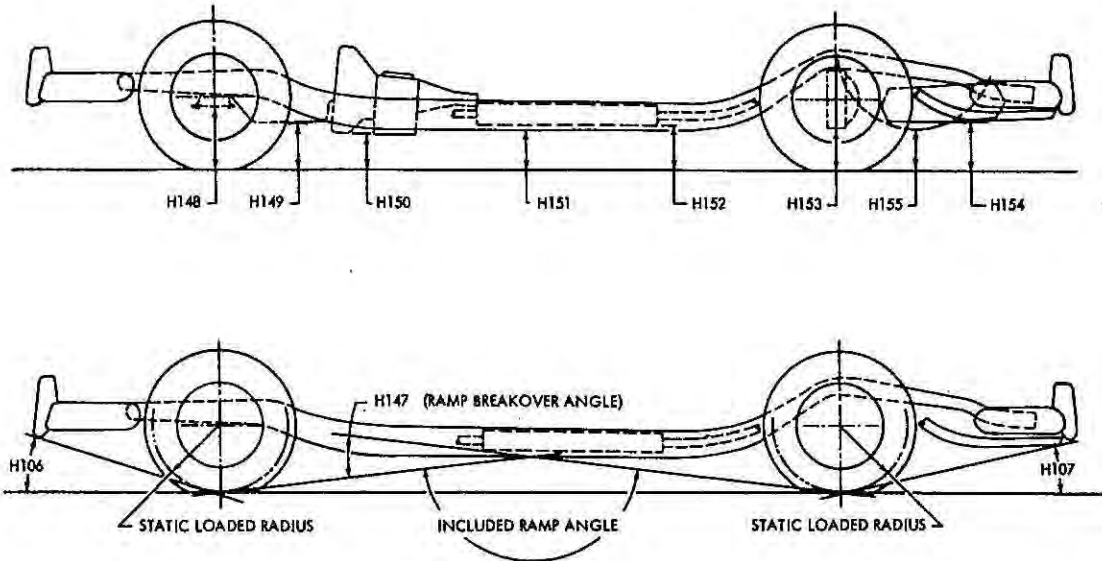

MODEL	Ref. No.	TV1		TP1		TP2	
		Exc St Wg	Sta. Wag.	Exc St Wg	Sta. Wag.	Exc St Wg	Sta. Wag.
Angle of approach	H106	22.6°(a)	23.9°(a)	22.4°(a)	23.8°(a)	22.1°(a)	23.5°(a)
Angle of departure	H107	13.7°(a)	9.9°(a)	13.4°(b)	10.0°(b)	13.1°(b)	10.0°(b)
Ramp breakover angle	H147	12.6°	12.2°	12.1°	11.7°	11.6°	11.7°
Front suspension to ground	H148	6.1	6.5		7.0	6.4	6.9
Oil pan to ground	H149	6.0(c)	6.3(d)	6.2	6.6	6.2	6.6
Flywheel housing to ground	H150	5.9	6.2	6.8(e)	7.0(f)	6.0(g)	6.4(h)
Frame structure to ground	H151	5.5	5.6	6.3	6.4	6.1	6.3
Exhaust system to ground	H152	5.5(i)		5.3(j)	4.8(j)	5.1(j)	4.8(j)
Rear axle differential to ground	H153	6.8	6.5	6.9	6.7		
Fuel tank to ground	H154	6.4	5.6	7.2	10.8	7.0	10.8
Spare tire well to ground	H155	10.7	9.7	15.0	6.8	14.7	6.8
Minimum running ground clearance	H156	5.5(i)		5.3(j)	4.8(j)	5.1(j)	4.8(j)

(a) At sheet metal.

(b) At bumper.

(c) 5.7 with 225 cu.in. engine.

(d) 6.0 with 225 cu.in. engine.

(e) 6.7 with auto. trans.

(f) 6.9 with auto. trans.

(g) 6.1 with auto. trans.

(h) 6.5 with auto. trans.

(i) At exhaust pipe.

(j) At muffler.

MAKE OF CAR VALIANT-PLYMOUTH MODEL YEAR 1963 DATE ISSUED 8-9-62 REVISED (\*)

## FRONT COMPARTMENT DIMENSIONS

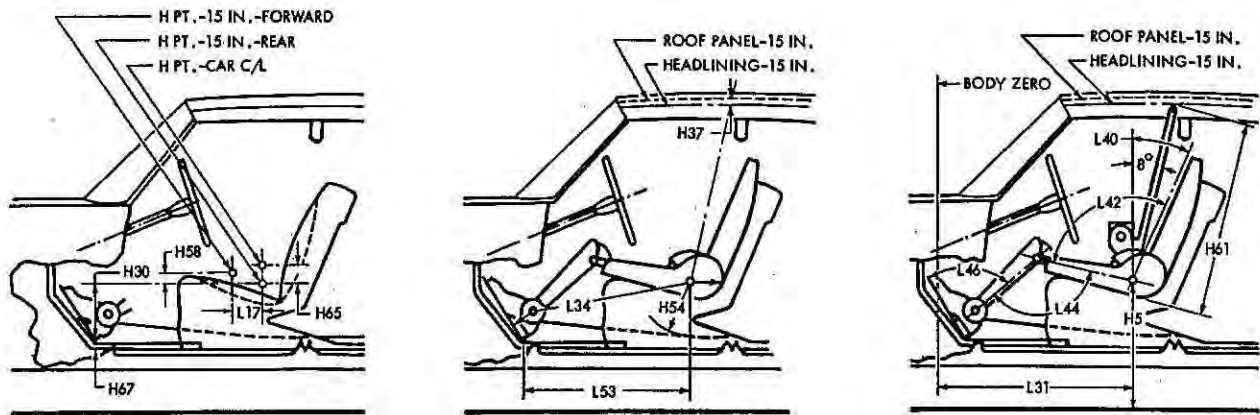

MODEL	Ref. No.	Valiant				
		V-100 & V-200		V-200	Signet 200	
		Sedans	Sta. Wag.	Conv. Cpe.	2D HT	Conv. Cpe.
H Point to body zero line	L31a	42.8			43.8	
H Point to ground	H5a	18.6	18.4	18.6	18.4	
Effective head room	H61a	38.0	38.3	39.5	38.2	39.9
Headlining to roof height	H37	0.8	0.5	0	0.8	0
Maximum effective leg room - accelerator	L34a	40.0			40.9	
H Point to heel point	H30a	8.7			8.4	
Depressed floor covering thickness	H67a	0.38				
Back angle	L40a	24°			22°	
Hip angle	L42a	90°			94°	
Knee angle	L44a	116°			126°	
Foot angle	L46a	76°			82°	
H Point differential, side to center	H65a					
H Point to tunnel	H54a	5.3			5.1	
H Point to accelerator floor point	L53a	32.5			33.5	
H Point travel	L17a	4.5				
H Point rise	H58a	1.2			0.7	

MAKE OF CAR VALIANT-PLYMOUTH MODEL YEAR 1963 DATE ISSUED 8-9-62 REVISED (\*)

## FRONT COMPARTMENT DIMENSIONS

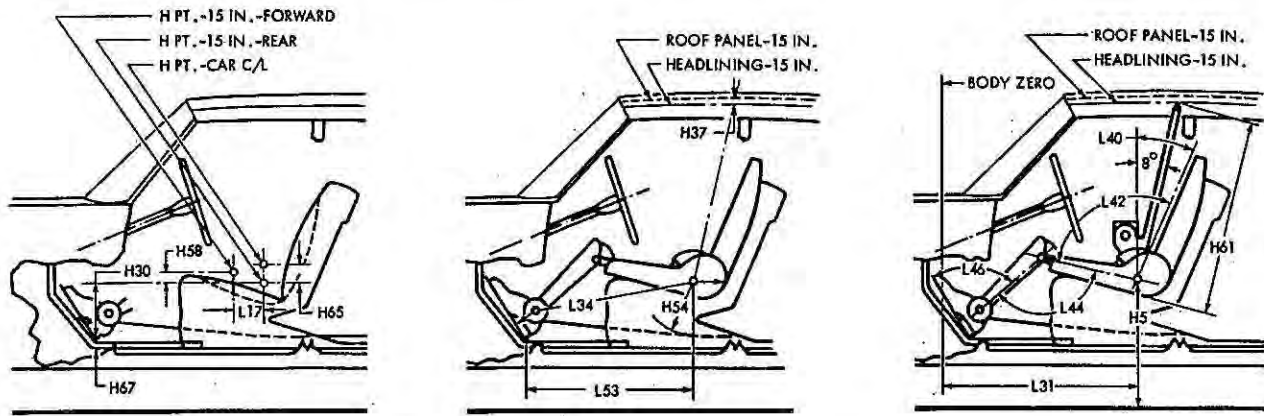

MODEL	Ref. No.	TP1		TP2				
		Sd & HT	Sta. Wag.	- L, - M, - H		- H	- P	
				Sd & HT	Sta. Wag.	Cv. Cpe.	2D HT	Cv. Cpe.
H Point to body zero line	L31a	44.5					44.7	
H Point to ground	H5a	19.1	19.0	18.9	19.0	18.9	19.2	
Effective head room	H61a	38.1	38.4	38.1	38.4	39.9	37.9	39.7
Headlining to roof height	H37	0.8	0.5	0.8	0.5	0	0.8	0
Maximum effective leg room - accelerator	L34a	41.9						
H Point to heel point	H30a	8.1					8.4	
Depressed floor covering thickness	H67a	0.38						
Back angle	L40a	25°					24°	
Hip angle	L42a	96°					95°	
Knee angle	L44a	128°					130°	
Foot angle	L46a	90°						
H Point differential, side to center	H65a							
H Point to tunnel	H54a	5.4					5.7	
H Point to accelerator floor point	L53a	34.2					34.4	
H Point travel	L17a	4.5						
H Point rise	H58a	1.2					0.7	

MAKE OF CAR VALIANT-PLYMOUTH MODEL YEAR 1963 DATE ISSUED 8-9-62 REVISED( )

## REAR COMPARTMENT DIMENSIONS

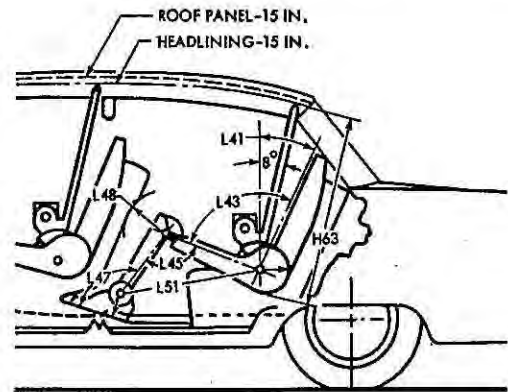
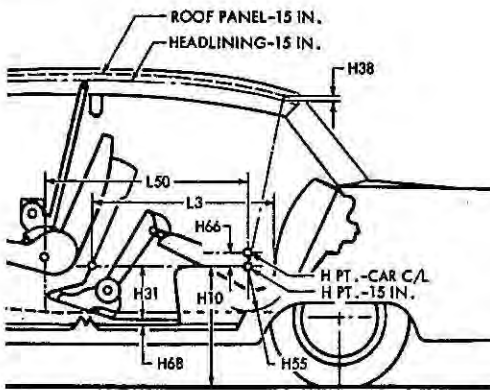

MODEL	Ref. No.	Valiant				
		V-100, V-200		V-200	Signet 200	
		Sedans	Sta. Wag.	Conv. Cpe.	2D HT	Conv. Cpe.
H Point couple distance	L50a	32.7			31.7	
H Point to ground	H10a	19.0	18.5		19.0	
Effective head room	H63a	37.2	37.9	37.6	37.2	37.8
Headlining to roof height	H38	0.8	0.5	0	0.8	0
Minimum effective leg room	L51a	35.5			34.8	
H Point to heel point	H31a	11.6				
Depressed floor covering thickness	H68a	0.38				
Minimum knee room	L48a	4.2			3.2	
Rear compartment room	L3	27.9	27.6	27.9	26.9	
Back angle	L41a	24°				
Hip angle	L43a	86°				
Knee angle	L45a	92°			87°	
Foot angle	L47a	113°				
H Point differential, side to center	H66a					
H Point to tunnel	H55a	5.5°				

# AMA Specifications – Passenger Car

MAKE OF CAR VALIANT-PLYMOUTH MODEL YEAR 1963 DATE ISSUED 8-9-62 REVISED(•) \_\_\_\_\_

## REAR COMPARTMENT DIMENSIONS

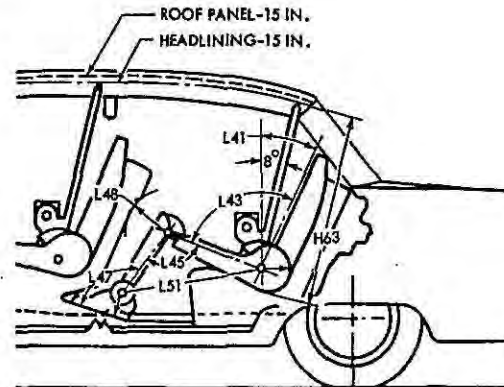
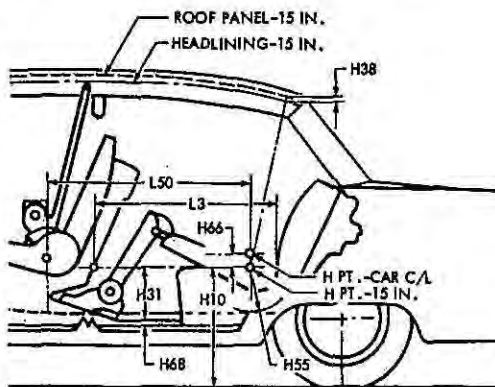

MODEL	Ref. No.	TP1				TP2			
		Sd & HT	Sta. Wag.	- L, - M, - H		- H	- P		
				Sd & HT	St. Wag.		Cv. Cpe.	2D HT	Cv. Cpe.
H Point couple distance	L50a	34.0				32.8	34.0	32.8	
H Point to ground	H10a	19.1	18.7	18.8	18.6	18.9	19.0		
Effective head room	H63a	37.5	38.5	37.5	38.5	37.6	37.5	37.6	
Headlining to roof height	H38	0.8	0.5	0.8	0.5	0	0.8	0	
Minimum effective leg room	L51a	36.4				35.2	36.9	35.7	
H Point to heel point	H31a	11.0							
Depressed floor covering thickness	H68a	0.38							
Minimum knee room	L48a	4.4				3.4	3.6	2.4	
Rear compartment room	L3	28.1	27.9	28.1	27.9	27.3	28.1	27.3	
Back angle	L41a	26°	24°	26°	24°	25°	26°	25°	
Hip angle	L43a	90°	89°	90°	89°	87°	93°	89°	
Knee angle	L45a	97°				91°	105°	98°	
Foot angle	L47a	121°				118°	121°	117°	
H Point differential, side to center	H66a								
H Point to tunnel	H55a	5.2°				5.3	5.2°	5.3°	



# AMA Specifications – Passenger Car

MAKE OF CAR VALIANT-PLYMOUTH MODEL YEAR 1963 DATE ISSUED 8-9-62 REVISED(\*) 1-16-63

## SEAT AND ENTRANCE DIMENSIONS

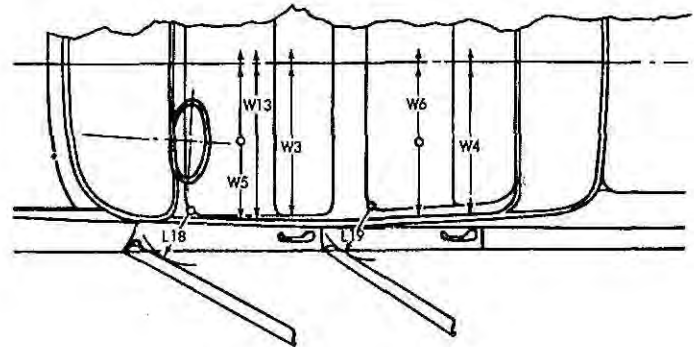
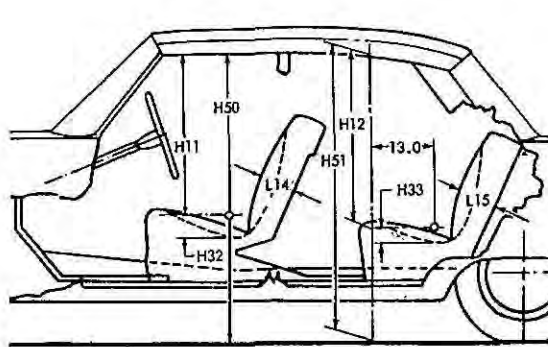

MODEL	Ref. No.	Valiant					
		V-100, V-200		V-200	Signet 200		
		Sedans	Sta. Wag.	Conv. Cpe.	2D HT	Conv. Cpe.	
Shoulder room - front	W3a	54.2					
Hip room - front	W5a	56.9					
Seat width - front	W16a	52.0			Bucket seats 23.6		
Upper body opening to ground - front	H50a	49.0	48.8	--	49.0	--	
Entrance height - front	H11a	30.5		--	30.6		
Entrance foot clearance - front	L18	13.9			14.8		●
Seat cushion deflection - front	H32a	4.0			3.4		
Seat back thickness - front	L14	5.5			5.6		
Shoulder room - rear	W4a	54.4					
Hip room - rear	W6a	57.0		46.4	57.0	46.4	
Upper body opening to ground - rear	H51a	48.9	48.5	--	48.9	--	
Entrance height - rear	H12a	27.5		--	27.5	--	
Entrance foot clearance - rear	L19	8.0 (a)	11.0	8.0	7.4		●
Seat cushion deflection - rear	H33a	4.3			3.4		
Seat back thickness - rear	L15	5.6	5.0	5.6			

(a) 4-Door Sedan: 11.0

MAKE OF CAR VALIANT-PLYMOUTH MODEL YEAR 1963 DATE ISSUED 8-9-62 REVISED(•) 1-16-63

**SEAT AND ENTRANCE DIMENSIONS**

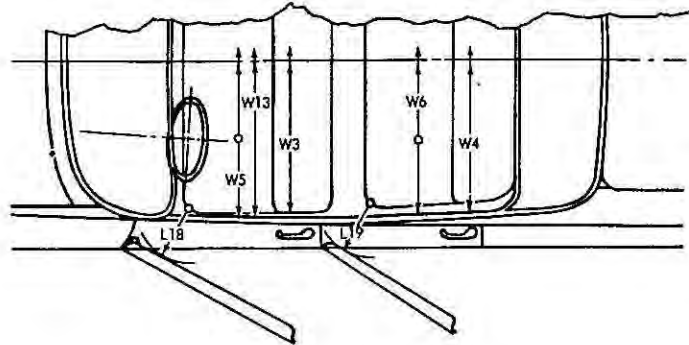
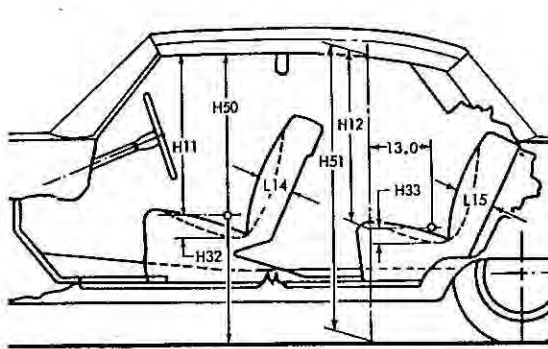

MODEL	Ref. No.	TP1		TP2				
		Sd & HT	Sta. Wag.	- L, - M, - H		- H Cv. Cpe.	- P	
				Sd & HT	St. Wag.		2D HT	Cv. Cpe.
Shoulder room - front	W3a	57.5						
Hip room - front	W5a	60.8						
Seat width - front	W16a	55.0					Bucket seats 23.6	
Upper body opening to ground - front	H50a	49.6(a)	49.5	49.4(b)	49.5	--	49.3	--
Entrance height - front	H11a	30.5(c)	30.5	30.5(c)	30.5	--	30.1	--
Entrance foot clearance - front	L18	16.3						
Seat cushion deflection - front	H32a	3.9					3.4	
Seat back thickness - front	L14	6.5					5.6	
Shoulder room - rear	W4a	57.8			47.9	57.8	47.9	
Hip room - rear	W6a	61.0			50.0	61.0	50.0	
Upper body opening to ground - rear	H51a	49.2	48.9	49.0(d)	48.8	--		
Entrance height - rear	H12a	28.3(e)	28.2	28.3(e)	28.2	--	28.2	--
Entrance foot clearance - rear	L19	12.4						
Seat cushion deflection - rear	H33a	4.3					3.4	
Seat back thickness - rear	L15	7.3	5.5	7.3	5.5	5.7	7.3	5.7

(a) 2D HT 49.5. (b) 2D HT & 4D HT 49.3. (c) Hardtops 30.4. (d) Hardtop 48.9.  
(e) Hardtops 28.2.

# AMA Specifications – Passenger Car

MAKE OF CAR VALIANT-PLYMOUTH MODEL YEAR 1963 DATE ISSUED 8-9-62 REVISED(•)

## VISION AND CONTROL DIMENSIONS

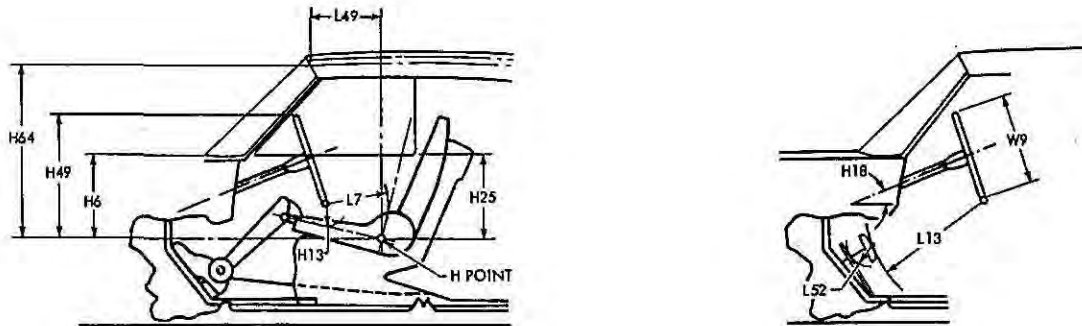

MODEL	Ref. No.	TV1	TP1, TP2
H Point to windshield bottom DLO	H6a	19.3	20.3
H Point to windshield upper DLO	H64a	31.1	31.7
H Point to windshield upper DLO	L49a	15.3	13.5
Belt height - front	H25a	16.8	17.0
Steering wheel center to centerline of car	W7	13.7	15.8
Steering wheel maximum outside diameter	W9	16.5	
Steering column angle - horizontal	H18	3.0°	
H Point to top of steering wheel	H49a	22.8	23.3
Steering wheel torso clearance	L7a	10.1	11.1
Steering wheel thigh clearance	H13a	3.1	3.9
Brake pedal knee clearance	L13	24.7	
Brake pedal to accelerator	L52a	2.5	3.6
Tumble-home	W122a	12.5°	14.0°

# AMA Specifications – Passenger Car

MAKE OF CAR VALIANT-PLYMOUTH MODEL YEAR 1963 DATE ISSUED 8-10-62 REVISED(\*) 1-16-63

## LUGGAGE COMPARTMENT

MODEL	Ref. No.	TV1		TP1	TP2	
		Sd & HT	Conv. Cpe.	Sd & HT	Sd & HT	Conv. Cpe.
Usable luggage capacity (See instructions)		14.1		17.3		●
Liftover height*	H301a	24.6		27.0	26.7	
Position of spare tire storage		Hor., in floor well		Hor., on right side of kick-up		
Method of holding lid open		Torsion bar				

## THIRD SEAT DIMENSIONS

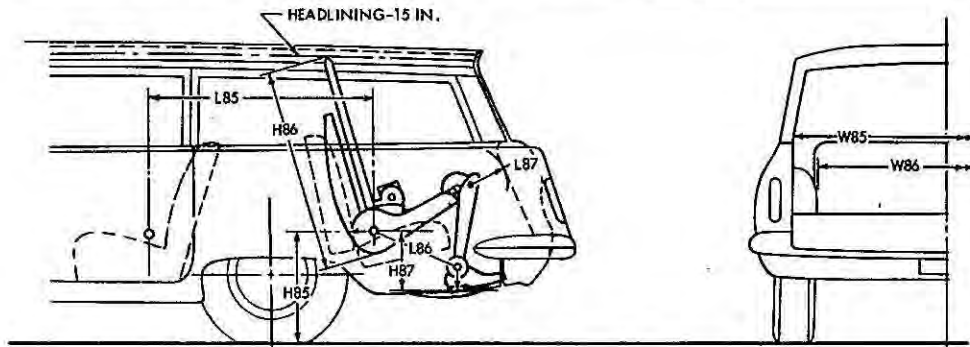

MODEL	Ref. No.	TP1, TP2 NA on TV1
Seat facing direction		Rear
Shoulder room	W85a	59.0
Hip room	W86a	45.2
H Point couple distance	L85a	36.9
H Point to ground	H85a	20.9
Effective head room	H86a	35.4
Effective leg room	L86a	32.5
H Point to heel point	H87a	13.2
Knee room	L87a	12.0
Back angle	L88a	28°
Hip angle	L89a	90°
Knee angle	L90a	79°
Foot angle	L91a	99°

\* Vertical dimension from luggage compartment lower opening to ground.

MAKE OF CAR VALIANT-PLYMOUTH MODEL YEAR 1963 DATE ISSUED 8-1-62 REVISED(\*) 1-16-63

**STATION WAGON—CARGO SPACE DIMENSIONS**

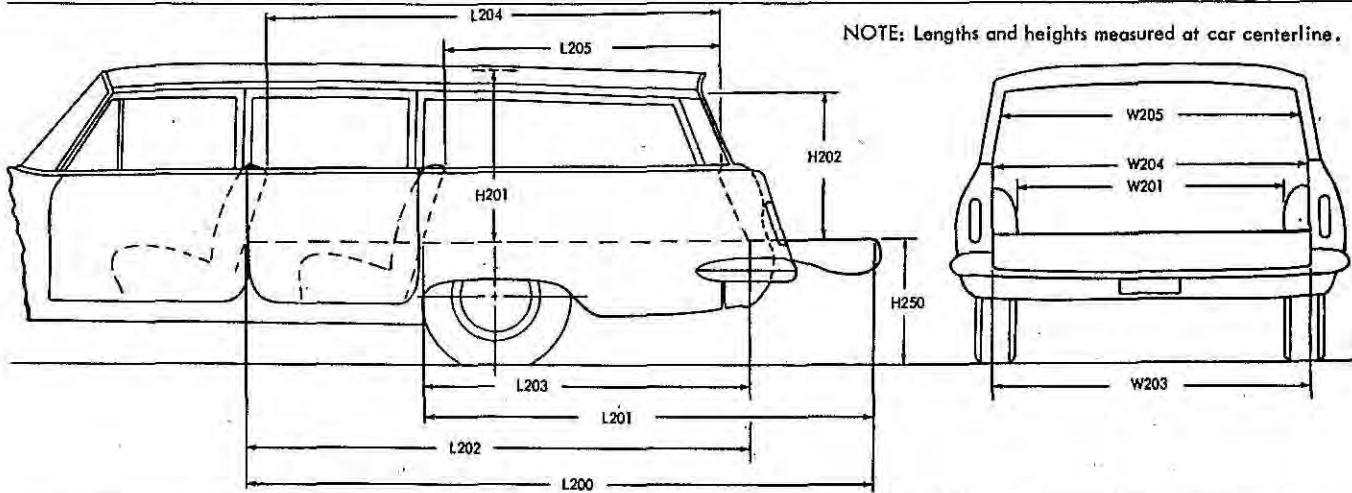

MODEL	Ref. No.	TV1	TP1, TP2
Floor length from back of front seat at floor level to end of lowered tail gate or floor	L200	105.3	117.9
Floor length from back of second seat at floor level to end of lowered tail gate or floor	L201	74.9	83.2
Floor length from back of front seat at floor level to inside of closed tail gate	L202	83.8	94.3
Floor length from back of second seat at floor level to inside of closed tail gate	L203	51.8	56.6
Minimum horizontal distance from top rear of front seat back to inside of tail gate at belt	L204	71.4	81.6
Minimum horizontal distance from top rear of second seat back to inside of tail gate at belt	L205	38.6	45.7
Maximum width of cargo space at floor - specify location	W200a	52.6 (a)	59.4 (a)
Minimum distance between wheel houses at floor level	W201	43.5	45.0
Rear end opening width at floor	W203	44.3	49.0
Rear end opening width at belt	W204	43.3	45.7
Maximum width of rear opening above belt	W205	42.8	44.9
Maximum height - floor covering to headlining at centerline of rear axle	H201	30.4	30.9
Maximum height of rear opening - tail and lift gates open	H202	26.1	27.3
Platform height from ground to top of tail gate floor covering at rear most edge of tail gate - curb weight	H250	24.0	27.9
Rear end closure (e.g., one piece door, hinged left - sliding glass, drop tail gate)		Sliding glass, drop tail gate	
Cargo volume index (cu. ft.) W4 x L204 x H201 1728		68.3	84.3

(a) Immediately forward of wheelhouse.

# AMA Specifications – Passenger Car

MAKE OF CAR	VALIANT-PLYMOUTH	MODEL YEAR	1963	DATE ISSUED	8-10-62	REVISED (e)						
		TV1			TP1, TP2							
MODEL		2D SD	2D HT	Cv Cp	4D Sd	Sta Wag	2D Sd	2D HT	Cv Cp	4D Sd	4D HT	Sta Wag

## BODY—MISCELLANEOUS INFORMATION

Drs. hinged (front, rear)	Front doors	Front										
	Rear doors	Front										
Type of finish (lacquer, enamel, other)		Synthetic enamel										
Hood hinge location (front, rear)		Rear										
Hood counterbalanced (yes, no)		Yes										
Hood release control (internal, external)		External										
Vehicle (Serial) No. Location		Left front door hinge post										
Engine No. Location		Not applicable										
Theft protection - type		Ignition key start, Ignition switch terminal block, Door locks										
Vent window control method (crank, friction pivot)	Front	Friction pivot										
	Rear	None										
Seat cushion type	Front	(a)	(c)	(a)(d)	(a)	(a)	(a)	(a)(e)	(a)(e)	(a)	(a)	(a)
	Rear	(a)	(a)	(b)	(a)	(a)	(a)	(a)	(b)	(a)	(a)	(a)
Seat back type	Front	(a)	(c)	(a)(d)	(a)	(a)	(b)	(b)(e)	(b)(e)	(a)(f)	(b)	(a)(f)
	Rear	(a)	(a)	(b)	(a)	(a)	(a)	(a)	(b)	(a)	(a)	(b)
Windshield type (single curved, compound curved, other)		Single, curved										
Rear window type (flat, curved, one piece, three piece)		1-piece, curved	Plas-tic	1-pcs, curve	1-pcs, flat	1-piece, curved	Plas-tic	1-piece, curved				
Side glass type (curved, flat)		Flat										
Side glass exposed surface area		1303	1344	1196	1223	2345	1153	1320	1146	1194	1224	2340
Windshield glass exposed surface area		995	995	995	995	995	1147	1147	1147	1147	1147	1147
Backlight glass exposed surface area		970	970	1000	970	612	917	917	1140	917	917	691
Total glass exposed surface area		3268	3309	3191	3188	3952	3217	3384	3433	3258	3288	4178

- (a) Formed Wire.    (b) Coil.    (c) Zigzag.    (d) Signet 200, Zigzag.  
 (e) Sport Fury, Zigzag.    (f) Fury, Coil.

# AMA Specifications – Passenger Car

MAKE OF CAR VALIANT-PLYMOUTH MODEL YEAR 1963 DATE ISSUED 8-8-62 REVISED (\*) 1-16-63

## MAJOR OPTIONAL ITEMS - WEIGHTS

VALIANT	CURB WEIGHT - POUNDS			% PASS. WEIGHT DISTRIBUTION				SHIPPING * WEIGHT
	Front	Rear	Total	Pass. In Front		Pass. In Rear		
				Front	Rear	Front	Rear	
Model <u>V-100, TV1-L</u>								
2-Door Sedan 21	1445	1195	2640	50.5	49.5	19.8	80.2	2515 ●
4-Door Sedan 41	1455	1210	2665	50.5	49.5	19.8	80.2	2535 ●
Station Wagon, 6-Pass. 45	1410	1415	2825	50.5	49.5	19.8	80.2	2700 ●
<u>V-200, TV1-H</u>								
2-Door Sedan 21								2515 ●
Convertible Coupe 27	1495	1265	2760	50.5	49.5	19.8	80.2	2640 ●
4-Door Sedan 41	1455	1220	2675	50.5	49.5	19.8	80.2	2555
Station Wagon 45	1410	1425	2835	50.5	49.5	19.8	80.2	2715 ●
<u>SIGNET 200, TV1-P</u>								
2-Door Hardtop 23	1470	1230	2700	49.8	50.2	19.8	80.2	2570 ●
Convertible Coupe 27	1505	1285	2790	49.8	50.2	19.8	80.2	2675 ●
<u>PLYMOUTH 6</u>								
<u>SAVOY, TP1-L</u>								
2-Door Sedan 21	1625	1515	3140	50.7	49.3	18.6	81.4	2980 ●
4-Door Sedan 41	1655	1520	3175	50.7	49.3	18.6	81.4	3020 ●
Station Wagon, 6-Pass. 45	1565	1910	3475	50.7	49.3	18.6	81.4	3325 ●
Station Wagon, 9-Pass. 45	1560	1980	3540	50.7	49.3	18.6	81.4	3375 ●
<u>BELVEDERE, TP1-M</u>								
2-Door Sedan 21	1625	1525	3150	50.7	49.3	18.6	81.4	3000 ●
2-Door Hardtop 23	1645	1510	3155	50.7	49.3	18.6	81.4	3025 ●
4-Door Sedan 41	1655	1530	3185	50.7	49.3	18.6	81.4	3020 ●
<u>FURY, TP1-H</u>								
2-Door Hardtop 23								3030 ●
4-Door Sedan 41	1660	1555	3215	50.7	49.3	18.6	81.4	3075 ●
<u>Accessories &amp; Equipment Differential Weights</u>								<u>Remarks</u>
Automatic Transmission	+ 25	+ 5	+ 30	Valiant only.				
Radio	+ 5	0	+ 5	Valiant only.				
Heater	+ 20	0	+ 20	Valiant only.				
Power Steering	+ 45	- 5	+ 40	Valiant only.				
Undercoat	+ 25	+ 20	+ 45	Valiant only.				
Automatic Transmission	+ 10	+ 10	+ 20	Plymouth 6 only.				
Power Steering	+ 40	0	+ 40	Plymouth 6 only.				
Power Brakes	+ 5	0	+ 5	Plymouth 6 only.				
Power Seats	+ 20	+ 15	+ 35	Plymouth 6 only.				
Power Windows	+ 10	+ 15	+ 25	Plymouth 6 only.				
Radio	+ 10	0	+ 10	Plymouth 6 only.				
Heater	+ 25	+ 5	+ 30	Plymouth 6 only.				
Air Conditioner	+ 100	0	+ 100	Plymouth 6 only.				
Undercoat - Sedans	+ 30	+ 35	+ 65	Plymouth 6 only.				
- Station Wagon	+ 35	+ 10	+ 45	Plymouth 6 only.				

\* These are weights that are reported to states for licensing purposes.





## DIMENSION DEFINITIONS

- W3a** SHOULDER ROOM - FRONT. The minimum lateral dimension between the door garnish moldings or nearest interference. Measured at H Point station.
- W4a** SHOULDER ROOM - REAR. Measured in the same manner as W3a.
- W5a** HIP ROOM - FRONT. The lateral dimension through H Point to trimmed surfaces.
- W6a** HIP ROOM - REAR. Measured in the same manner as W5a.
- W7** STEERING WHEEL CENTER TO CENTERLINE OF CAR. Measured horizontally from steering wheel center to centerline of car. The point at steering wheel center is located in the surface plane of wheel.
- W9** STEERING WHEEL MAXIMUM OUTSIDE DIAMETER. Define if other than round.
- W16a** SEAT WIDTH - FRONT. The maximum trimmed width of front seat cushion.
- W85a** SHOULDER ROOM - THIRD SEAT. Measured in the same manner as W3a.
- W86a** HIP ROOM - THIRD SEAT. Measured in the same manner as W5a.
- W101** TREAD - FRONT. Measured at centerline of tires, with nominal camber, at ground.
- W102** TREAD - REAR. Measured at centerline of tires at ground.
- W103** MAXIMUM OVERALL CAR WIDTH. Include bumpers, moldings, or sheet metal protrusions.
- W106** FRONT FENDER OVERALL WIDTH. Measured at centerline of front wheels, excluding moldings.
- W107** REAR FENDER OVERALL WIDTH. Measured at centerline of rear wheels, excluding moldings.
- W116** MAXIMUM OVERALL BODY WIDTH. Measured across body, excluding hardware and applied moldings, but including fenders when integral with body.
- W117** MAXIMUM BODY WIDTH AT #2 PILLAR. Measured across body at #2 pillar, excluding hardware and applied moldings.
- W120a** MAXIMUM OVERALL CAR WIDTH, FRONT DOORS OPEN. Measured with front doors in maximum hold-open position.
- W121a** MAXIMUM OVERALL CAR WIDTH, REAR DOORS OPEN. Measured in same manner as W120a.
- W122a** TUMBLE-HOME. The angle from vertical to the front door glass outer surface or the chord of a curved door glass, measured at the front H Point station.
- L3** REAR COMPARTMENT ROOM. The horizontal dimension from the back of front seat to front of rear seat back at a height tangent to the top of rear seat cushion.
- L7a** STEERING WHEEL TORSO CLEARANCE. The minimum distance from the back edge of steering wheel, in straight-ahead position, to the Torso Line.
- L13** BRAKE PEDAL KNEE CLEARANCE. The minimum dimension from the lower edge of the steering wheel to the brake pedal face centerline.
- L14** SEAT BACK THICKNESS - FRONT. The maximum thickness of the seat back, excluding bolsters.
- L15** SEAT BACK THICKNESS - REAR. Measured in the same manner as L14.
- L17a** H POINT TRAVEL. The horizontal dimension between the H Point in the most forward and rearward seat positions.
- L18** ENTRANCE FOOT CLEARANCE - FRONT. The minimum horizontal dimension between seat and normal line of door or pillar at a height between the sill plate bead and 4.0 inches above the bead. Door should be in the maximum hold-open position.
- L19** ENTRANCE FOOT CLEARANCE - REAR. Measured in the same manner as L18 on four-door models. On two-door styles, the minimum dimension between rear corner of front seat, with front seat back tilted forward, and trimmed lock pillar, built-in quarter armrest panel, or rear seat cushion at a height between the sill plate bead and 4.0 inches above the bead.
- L30** BODY ZERO LINE TO ACTUAL FRONT OF DASH. If actual Front of Dash is to the rear of Body Zero Line, it is identified by a minus (-) sign.
- L31a** H POINT TO BODY ZERO LINE - FRONT. Horizontal dimension.
- L34a** MAXIMUM EFFECTIVE LEG ROOM - ACCELERATOR. Measured along a diagonal line from ankle pivot center to H Point plus a constant of 10.0 inches. Measured with the right foot on accelerator pedal.
- L40a** BACK ANGLE - FRONT. The angle between a vertical line through the H Point and the Torso Line.
- L41a** BACK ANGLE - REAR. Measured in the same manner as L40a.
- L42a** HIP ANGLE - FRONT. The angle between Torso Line and a line extending from knee pivot center to H Point.
- L43a** HIP ANGLE - REAR. Measured in the same manner as L42a.
- L44a** KNEE ANGLE - FRONT. The angle between a line from H Point to knee pivot center and a line from the knee pivot center to the ankle pivot center.
- L45a** KNEE ANGLE - REAR. Measured in the same manner as L44a.
- L46a** FOOT ANGLE - FRONT. The angle between a line extended from the knee pivot center through the ankle pivot center and a line tangent to the sole and heel of monkkin bare foot.
- L47a** FOOT ANGLE - REAR. Measured in the same manner as L46a.
- L48a** MINIMUM KNEE ROOM - REAR. The minimum dimension from the knee pivot center to the back of front seat back.
- L49a** H POINT TO WINDSHIELD UPPER DLO. The horizontal dimension from H Point to the point of tangency of horizontal line of vision (described in dimension H64a) with body upper structure.

## DIMENSION DEFINITIONS (cont.)

- L50a H POINT COUPLE DISTANCE. The horizontal dimension from the front seat H Point to the rear seat H Point.
- L51a MINIMUM EFFECTIVE LEG ROOM – REAR. Measured along a diagonal line from ankle pivot center to H Point plus a constant of 10.0 inches. Measured with the foot positioned to nearest interference between seat structure and toe, instep or lower leg.
- L52a BRAKE PEDAL TO ACCELERATOR. The minimum dimension from center of brake pedal face to accelerator. Measured in the side view.
- L53a H POINT TO ACCELERATOR FLOOR POINT. The horizontal dimension from intersection of accelerator and depressed floor covering to the H Point.
- L85a H POINT COUPLE DISTANCE – THIRD SEAT. The horizontal dimension from the second seat H Point to the third seat H Point.
- L86a EFFECTIVE LEG ROOM – THIRD SEAT. Measured in the same manner as L51a. With rear-facing third seat, foot is positioned in foot well or to nearest interference with rear end or rear closure.
- L87a KNEE ROOM – THIRD SEAT. Measured in the same manner as L48a. With rear-facing third seat, dimension is measured to rear closure.
- L88a BACK ANGLE – THIRD SEAT. Measured in the same manner as L40a.
- L89a HIP ANGLE – THIRD SEAT. Measured in the same manner as L42a.
- L90a KNEE ANGLE – THIRD SEAT. Measured in the same manner as L44a.
- L91a FOOT ANGLE – THIRD SEAT. Measured in the same manner as L46a.
- L101 WHEELBASE.
- L102 TIRE SIZE.
- L103 OVERALL LENGTH. Include bumper guards if standard equipment.
- L104 OVERHANG – FRONT. Measured from C/L of front wheels to front of car, including bumper guards if standard equipment.
- L105 OVERHANG – REAR. Measured from C/L of rear wheels to rear of car, including bumper guards if standard equipment.
- L123 BODY UPPER STRUCTURE LENGTH AT CAR CENTERLINE. The horizontal dimension from the theoretical intersection of extended windshield glass plane and normal cowl surface to the theoretical intersection of extended back window glass plane and normal deck surface; or in the case of a Fastback roof or Station Wagon, to back glass lower reveal molding, or rubber when molding is not used.
- L127 BODY ZERO LINE TO CENTERLINE OF REAR WHEELS. A horizontal dimension.
- L128a HOOD LENGTH AT CAR CENTERLINE. The horizontal dimension from the foremost point on sheet metal hood surface, excluding series identification or ornamentation, to the theoretical intersection of extended windshield glass plane and normal cowl surface.
- L129a DECK LENGTH AT CAR CENTERLINE. The horizontal dimension from the rearmost point of the body sheet metal (visible above bumper), excluding series identification or ornamentation, to the theoretical intersection of extended back window glass plane and normal deck surface.
- L130a BODY ZERO LINE TO WINDSHIELD COWL POINT. The horizontal dimension from body zero line to the theoretical intersection of extended windshield glass plane and normal cowl surface.
- H5a H POINT TO GROUND – FRONT. Vertical dimension.
- H6a H POINT TO WINDSHIELD BOTTOM DLO. Vertical dimension.
- H10a H POINT TO GROUND – REAR. Vertical dimension.
- H11a ENTRANCE HEIGHT – FRONT. The vertical dimension from H Point to upper trimmed body opening.
- H12a ENTRANCE HEIGHT – REAR. The vertical dimension from H Point to the upper trimmed body opening at a section 13.0 inches forward of the H Point.
- H13a STEERING WHEEL THIGH CLEARANCE. The minimum dimension from the bottom of steering wheel, in straight-ahead position, to centerline of thigh.
- H18 STEERING COLUMN ANGLE – HORIZONTAL. The angle the centerline of steering column makes with the horizontal.
- H25a BELT HEIGHT – FRONT. The vertical dimension from H Point to bottom of side window DLO.
- H30a H POINT TO HEEL POINT – FRONT. The vertical dimension from the H Point to the manikin accelerator heel point on the depressed floor covering.
- H31a H POINT TO HEEL POINT – REAR. The vertical dimension from the H Point to the manikin heel point on the depressed floor covering.
- H32a SEAT CUSHION DEFLECTION – FRONT. The vertical dimension from a point on the undepressed seat cushion to the depressed seat cushion. Measured at the H Point station.
- H33a SEAT CUSHION DEFLECTION – REAR. Measured in the same manner as H32a.
- H37 HEADLINING TO ROOF HEIGHT – FRONT. The dimension from the intersection of the headlining and the extended effective head room line to the roof panel. Measured perpendicularly to the roof panel.
- H38 HEADLINING TO ROOF HEIGHT – REAR. Measured in the same manner as H37.
- H49a H POINT TO TOP OF STEERING WHEEL. The vertical dimension from the H Point to top of steering wheel, in straight-ahead position.
- H50a UPPER BODY OPENING TO GROUND – FRONT. The vertical dimension from a point on the trimmed body opening to the ground. Measured at the H Point station.

**DIMENSION DEFINITIONS (cont.)**

- H51a UPPER BODY OPENING TO GROUND - REAR. The vertical dimension from a point on the trimmed body opening to the ground. Measured 13.0 inches forward of the H Point.
- H54a H POINT TO TUNNEL - FRONT. The minimum dimension from the H Point, at car centerline, to top of tunnel.
- H55a H POINT TO TUNNEL - REAR. Measured in the same manner as H54a.
- H58a H POINT RISE. The vertical dimension between the H Point in the most forward and rearward seat positions.
- H61a EFFECTIVE HEAD ROOM - FRONT. The dimension from H Point to the headlining, plus a constant of 4.0 inches. Measured along a line 8° to rear of vertical.
- H63a EFFECTIVE HEAD ROOM - REAR. Measured in the same manner as H61a.
- H64a H POINT TO WINDSHIELD UPPER DLO. Vertical dimension from H Point to highest horizontal line of vision through windshield at 15 inch section.
- H65a H POINT DIFFERENTIAL, SIDE TO CENTER - FRONT. The vertical dimension from side occupant H Point to center occupant H Point.
- H66a H POINT DIFFERENTIAL, SIDE TO CENTER - REAR. Measured in the same manner as H65a.
- H67a DEPRESSED FLOOR COVERING THICKNESS - FRONT. The vertical dimension from manikin accelerator heel point normally to underbody sheet metal immediately below heel point.
- H68a DEPRESSED FLOOR COVERING THICKNESS - REAR. Measured same as H67a.
- H85a H POINT TO GROUND - THIRD SEAT. Vertical dimension.
- H86a EFFECTIVE HEAD ROOM - THIRD SEAT. Measured in the same manner as H61a.
- H87a H POINT TO HEEL POINT - THIRD SEAT. Measured in the same manner as H31a.
- H101 OVERALL HEIGHT. Measured with full design load.
- H102 FRONT BUMPER TO GROUND. Minimum dimension.
- H104 REAR BUMPER TO GROUND. Minimum dimension.
- H106 ANGLE OF APPROACH. Minimum angle between ground and a line tangent to arc of front tire static loaded radius and touching the limiting point of interference on front bumper, bumper guard, or gravel deflector.
- H107 ANGLE OF DEPARTURE. Minimum angle between ground and a line tangent to arc of rear tire static loaded radius and touching the limiting point of interference on rear bumper, bumper guard, gravel deflector, tail pipe, fender or other interfering structure.
- H111 ROCKER PANEL TO GROUND - REAR. The vertical dimension from ground to bottom of rocker panel, excluding flanges. Measured at front of rear wheel opening.
- H112a ROCKER PANEL TO GROUND - FRONT. The vertical dimension from ground to bottom of rocker panel, excluding flanges. Measured at foremost point of rocker panel.
- H114 HOOD AT REAR TO GROUND. Measured from hood opening line on shroud, exclusive of moldings.
- H115 STEP HEIGHT - FRONT (DESIGN LOAD). The vertical dimension from top of sill plate bead, at C/L of front door sill plate, to ground.
- H116 STEP HEIGHT - REAR (DESIGN LOAD). Measured in same manner as dimension H115.
- H122 WINDSHIELD SLOPE ANGLE. The angle between a vertical line and the windshield surface at car centerline. On compound-curved windshields the chord of the arc is used and limited to that section of the windshield comprehended by an 18-inch chord.
- H130 STEP HEIGHT - FRONT (CURB LOAD). The vertical dimension from top of sill plate, at C/L of front door sill plate, to ground.
- H131 STEP HEIGHT - REAR (CURB LOAD). Measured in same manner as H130.
- H132 BOTTOM OF DOOR TO GROUND, OPEN - FRONT. Measured from bottom outside corner of door with door in maximum hold-open position.
- H133 BOTTOM OF DOOR TO GROUND, CLOSED - FRONT. Same point on door as H132 dimension, with door closed.
- H134 BOTTOM OF DOOR TO GROUND, OPEN - REAR. Measured in same manner as H132.
- H135 BOTTOM OF DOOR TO GROUND, CLOSED - REAR. Measured in same manner as H133.
- H136a BODY ZERO TO GROUND - FRONT. A vertical dimension measured at front wheel centerline.
- H137a BODY ZERO TO GROUND - REAR. A vertical dimension measured at rear wheel centerline.
- H147 RAMP BREAKOVER ANGLE. Supplement of included ramp angle (180° minus included ramp angle) over which car can pass without interference; measured with car sitting on a level surface, using lines tangent to arcs of front and rear static loaded radii and intersecting at point on underside of car which defines the smallest angle.
- H148 FRONT SUSPENSION TO GROUND. Minimum clearance measured from lower control arm inner shaft or lowest point on the car centerline.
- H149 OIL PAN TO GROUND. Minimum clearance measured from sheet metal or drain plug.
- H150 FLYWHEEL/CONVERTER HOUSING AND TRANSMISSION ASSEMBLY TO GROUND. Minimum clearance.
- H151 FRAME STRUCTURE TO GROUND. Minimum clearance measured approximately midway between front and rear axles. In this measurement, cross bars and X-members shall be considered part of frame.
- H152 EXHAUST SYSTEM TO GROUND. Minimum clearance. Specify location.
- H153 REAR AXLE DIFFERENTIAL SYSTEM TO GROUND. Minimum clearance.
- H154 FUEL TANK TO GROUND. Minimum clearance measured from sheet metal or drain plug, but excluding supports or straps.
- H155 SPARE TIRE WELL TO GROUND. Minimum clearance.
- H156 MINIMUM RUNNING GROUND CLEARANCE. Location of measurement on the car is to be clearly recorded.

## INDEX

SUBJECT	PAGE NO.	SUBJECT	PAGE NO.
Angles of Approach, Departure .....	25	Lamp Bulbs .....	13
Automatic Transmission .....	1, 16	Lamp Height & Spacing .....	14
Axis, Steering .....	21	Legroom .....	26, 27, 30
Axle, Rear .....	1, 17	Lengths - Overall .....	1, 23
Battery .....	10	Lifters, Valve .....	5
Bearings, Engine .....	4, 5, 6	Linings - Clutch, Brake .....	15, 19
Belts - Fan, Generator, Water Pump .....	9	Lubrication .....	6, 7, 15, 16, 17
Body - General Information, types .....	Title, 1, 22, 32	Motor, Starting .....	10
Exterior Dimensions .....	1, 22, 23, 24	Muffler .....	7
Interior Dimensions .....	26, 27, 28, 29, 30	Overdrive .....	16
Clearance Dimensions .....	25	Piston Pins & Rings .....	2, 4
Brakes - Parking, Service, Power .....	18, 19	Pistons .....	2
Camber .....	21	Power Brakes .....	18
Camshaft .....	5	Power Steering .....	20
Capacities .....		Power Teams .....	3
Cooling System .....	9	Propeller Shaft, Universal Joints .....	16, 17
Fuel Tank .....	8	Pumps - Oil, Fuel .....	7, 8
Lubricants .....		Water .....	9
Engine Crankcase .....	7	Radiator, Hoses .....	9
Transmission and Overdrive .....	15, 16	Ramp Break-over Angle .....	25
Rear Axle .....	17	Ratios - Axle .....	1, 3, 17
Carburetor .....	3, 8	Compression .....	1, 2, 3
Caster .....	21	Steering .....	20
Choke, Automatic .....	8	Transmission .....	15, 16
Circuit Breakers, Fuses .....	14	Rear Axle .....	1, 3, 17
Clearance, Ground .....	25	Regulator - Generator .....	10
Clutch - Pedal Operated .....	15	Rims .....	18
Coil, Ignition .....	11	Rings, Piston .....	4
Connecting Rods .....	4	Rods - Connecting .....	4
Cooling System .....	9	Shock Absorbers, Front & Rear .....	19
Crankcase Ventilation .....	7	Spark Plugs .....	11
Crankshaft .....	5	Speedometer .....	12
Cylinders and Cylinder Head .....	2	Springs - Front & Rear Suspension .....	20, 21
Dimension Definitions .....	34, 35, 36	Valve, Engine .....	6
Distributor - Ignition .....	11	Stabilizer (Sway Bar) - Front & Rear .....	20, 21
Electrical System .....	10, 11, 12, 13, 14	Starting Motor .....	10
Engine .....		Steering .....	20, 21
Bore, Stroke, Displacement, Type .....	1, 2	Suppression - Ignition, Radio .....	11
Compression Ratio .....	1, 2	Suspension - Front & Rear .....	19, 20, 21
Firing Order, Cylinder Numbering .....	2, 11	Switches .....	12
General Information, H.P. & Torque .....	1, 2	Tailpipe .....	7
Lubrication .....	6, 7	Thermostat, Cooling .....	9
Power Teams .....	3	Timing, Engine & Valve .....	5, 6, 11
Exhaust System .....	7	Tires .....	1, 18
Fan, Cooling .....	9	Toe in .....	21
Filters - Engine Oil, Fuel System .....	7, 8	Torque Converter .....	16
Frame .....	19	Torque - Engine, Rated .....	1, 2, 3
Front Suspension .....	19, 20	Transmission - Types .....	1, 3, 8, 15, 16
Fuel, Fuel Pump, Fuel System .....	1, 2, 8	Automatic .....	1, 3, 8, 15, 16
Fuel Injection .....	1, 8	Manual & Overdrive .....	1, 3, 8, 15, 16
Fuses, Circuit Breakers .....	14	Ratios .....	15, 16
Generator and Regulator .....	10	Tread .....	1, 22
Glass .....	24, 32	Turning Diameter .....	20
Height (Lamps) .....	14	Unitized Construction .....	19
Headroom - Body .....	26, 27, 30	Universal Joints, Propeller Shaft .....	16, 17
Heights - Overall .....	1, 24	Valves - Intake & Exhaust .....	5, 6
Hood .....	23	Vibration Damper .....	5
Horns .....	12	Voltage Regulator .....	10
Horsepower - Brake, Taxable .....	1, 2, 3	Water Pump .....	9
Ignition System .....	11	Weights - Shipping, Curb .....	33
Inflation - Tires .....	18	Wheel Alignment .....	21
Instruments .....	7, 12	Wheelbase .....	1, 23
Kingpin (Steering Axis) .....	21	Wheels & Tires .....	18
		Wheel Spindle .....	21
		Widths - Car & Body .....	1, 22
		Windshield .....	24, 32
		Windshield Wiper .....	12