

AUTOMOBILE MANUFACTURERS ASSOCIATION CONSOLIDATED SPECIFICATION QUESTIONNAIRE

MAKE OF CAR:	CADILLAC	MODEL NAME	SYMBOL
COMPANY:		SEDAN 6239	ELDORADO CONV. 6267S
		SEDAN DEVILLE 6239D	ELDORADO COUPE 6237S
		COUPE 6237	SEDAN 6039
		COUPE DEVILLE 6237D	SEDAN 7523
MODEL YEAR: 1957	DATE NOVEMBER 12, 1956	COUPE CONV. 6267	SEDAN IMP. 7533

TABLE OF CONTENTS

General Specifications.....	1	Frame.....	16
Engine.....	2	Front Suspension.....	16
Electrical.....	8	Steering.....	17
Drive Units.....	12	Rear Suspension.....	18
Brakes.....	15	Body.....	19
Index.....	24		

- NOTES: 1. The specifications set forth herein are those in effect at the date of compilation and are subject to change without notice.
 2. All specifications are standard for the models under which they are listed unless otherwise indicated.
 3. All dimensions are nominal engineering dimensions unless otherwise indicated.
 4. Unless otherwise indicated, specifications apply to 5 or 6 passenger, 4-door sedan or equivalent.

GENERAL SPECIFICATIONS

Model	6239	6239D	6237	6237D	6267	6267S	6237S	6039	75		
Wheelbase	129.5							133	149.75		
Tread	Front				61.0						
	Rear				61.0						
Maximum Overall Dimensions	Length (L-103)		215.9	215.9	220.9	220.9	220.9	222.1	222.1	224.4	236.2
	Width (W-103)		80.0								
	Height (H-101)		59.1	59.1	57.7	57.7	58.2	58.4	57.9	59.1	61.6
Steering ratio—overall					19.5:i						
Turning diameter (curb to curb)					N. A.						
Shipping weight*					N. A.						
Transmission— (Specify standard, optional, not avail.)	Conventional				N. A.						
	Overdrive				N. A.						
	Automatic				STANDARD						
Axle ratio	Conventional				N. A.						
	Overdrive				N. A.						
	Automatic				N. A.						
Tire size	3.07:1**					3.36:1		3.07:1**		3.36:1*	
	8.00 X 15 - TUBELESS 4 PLY BLACK					***		8.00x15		****	
Engine	Type				90° V						
	No. of cylinders				8						
	Valve arrangement				OVERHEAD						
	Bore and stroke				4.000 x 3.625						
	Piston displacement, cu. in.				365						
	Standard compression ratio				10.0:1						
	Maximum bhp at engine rpm				(1)	300 @ 4800					
Maximum torque at rpm				(2)	400 @ 2800						

*Standard car weight, not including gas and water.

**3.36:1 OPTIONAL - STD ON ALL A/C CARS & ALL Q ENG. INST. 3.77 OPTIONAL ON 75

***8.20 x 15 W/S TUBELESS 4 PLY RATING (OPT. ON OTHER 60 & 62 MODELS)

****8.20 x 15 BLACK TUBELESS 6 PLY STD. (WHITE SIDEWALL OPT.)

(1) 325 @ 4800 Q ENGINE OPT. ON 6267S-37S ONLY.

(2) 400 @ 3300 Q ENGINE OPT. ON 6267S-37S ONLY.

AMA Consolidated Specification Questionnaire

MAKE OF CAR CADILLAC **MODEL YEAR** 1957

MODEL ALL

ENGINE—GENERAL

Type	V, In-line, other	V	
	Angle of V	90°	
No. of cylinders		8	
Valve arrangement		OVERHEAD	
Bore and stroke		4.000 x 3.625	
Piston displacement, cu. in.		365	
Numbering system (front to rear)	L. Bank	1 - 3 - 5 - 7	
	R. Bank	2 - 4 - 6 - 8	
Firing order		1 - 8 - 4 - 3 - 6 - 5 - 7 - 2	
Compression ratio	Standard Head	10.0:1 *	
	Optional Head	NONE	
Cylinders	Head Material	CAST IRON	
	Standard Optional	NONE	
	Sleeve—Wet, dry, other, none	NONE	
Number of mounting points	Front	TWO	
	Rear	ONE	
Taxable horsepower	(Dia. ² x No. Cyl.) 2.5	51.2	
Advertised max. brake horsepower at engine RPM*	Standard head	300 @ 4800 ** 325 @ 4800	
	Optional head	NONE	
	With fuel (Octane and method)	Standard Head	97 RESEARCH
		Optional Head	NONE
Max. torque (lb. ft. @ RPM)	Standard head	400 @ 2800	
	Optional head	NONE	
Recommended idle speed (neutral)		** 420 RPM (DRIVE RANGE)	

ENGINE—PISTONS

Material	ALUMINUM ALLOY		
Description and finish	T-SLOT-CAM GROUND-STANNATE COATED		
Weight (piston only) oz.	22.72		
Clearance	Top land	.020-.024 TO .035-.039 CAM GROUND	
	Skirt	Top	.0015
		Bottom	0
Ring groove depth	No. 1 ring	.208	
	No. 2 ring	.208	
	No. 3 ring	.208	
	No. 4 ring	NONE	

*Corrected as defined by SAE Engine Test Code, with the following standard power consuming accessories:

*EXPORT 8.3:1

**Q ENGINE - 490-510 RPM (DRIVE RANGE)

AMA Consolidated Specification Questionnaire

MAKE OF CAR CADILLAC **MODEL YEAR** 1957

MODEL ALL

ENGINE—RINGS

Type (top to bottom)	No. 1 oil or comp.	COMP
	No. 2 oil or comp.	COMP
	No. 3 oil or comp.	OIL
	No. 4 oil or comp.	NONE
No. rings above piston pin		3
Compression	Material	HIGH STRENGTH CAST IRON
	Coating	CHROME PLATED #1 LUBRITED #2
	Width	.0781
	Gap	.013 - .023
	Maximum wall thickness	.200
Oil	Material	CAST IRON
	Coating	NONE
	Width	.1875
	Gap	.013 - .023
	Maximum wall thickness	.150
Location of expanders		BEHIND RING

ENGINE—PISTON PINS

Material		1045 STEEL	
Length		3.093	
Diameter		1.00	
Type	Locked in rod, in piston, floating, etc.	LOCKED IN ROD	
	Bushing	In rod or piston	NONE
		Material	NONE
Clearance	In piston	.00005 - .0001"	
	In rod	PRESS FIT	
Direction offset in piston		1/16 TOWARD MAX THRUST SIDE	

ENGINE—CONNECTING RODS

Material		1041 STEEL
Weight (oz.)		23.49
Length (center to center)		6.625
Bearing	Material	DUREX 400
	Type (cast-in or removable)	REMOVABLE
	Effective length	.755 - .880
	Clearance	.0005 - .0021
	End play	.008 - .014 (TOTAL TWO RODS)

ENGINE—CRANKSHAFT

Material	1145 STEEL
Weight (lb.)	71.0

AMA Consolidated Specification Questionnaire

MAKE OF CAR CADILLAC **MODEL YEAR** 1957

MODEL ALL

ENGINE—CRANKSHAFT (cont.)

Vibration damper type		RUBBER ABSORPTION	
End thrust taken by bearing (No.)		REAR MAIN	
Crankshaft end play		.001 - .005	
Main bearing	Material	MORaine 400 1-4 BEARINGS (REAR MORaine DUREX 100)	
	Type (cast-in or removable)	REMOVABLE	
	Clearance	.0008 - .0025	
	Journal dia. and bearing effective length	No. 1	2.625 x .907
		No. 2	"
		No. 3	"
		No. 4	"
		No. 5	2.625 x 1.622
No. 6		NONE	
No. 7		NONE	
Direction offset from cyl. bore		NONE - SEE PISTON	
Connecting rod crankpin journal diameter		2.25	

ENGINE—CAMSHAFT

Material		G.M. 120 M CAST IRON	
Bearings	Material	STEEL BACKED BABBITT	
	Number	5	
Type of drive	Gear or chain		CHAIN
	Crankshaft gear or sprocket material		1118 or 1115 STEEL
	Camshaft gear or sprocket material		1115 STEEL
	Timing chain	Make	LINK BELT
		No. of links	46
		Width	.6875
Pitch		.500	

ENGINE—VALVE SYSTEM

Hydraulic lifters (yes, no)		YES
Special provision for valve rotation (intake, exhaust)		NO
Rocker ratio		1.65:1
Operating tappet clearance (indicate hot or cold)	Intake	AUTOMATIC
	Exhaust	"
Tappet clearance for timing	Intake	-
	Exhaust	-
Timing marks on fly-wheel, damper, other		VIBRATION DAMPER

AMA Consolidated Specification Questionnaire

MAKE OF CAR CADILLAC **MODEL YEAR** 1957

MODEL ALL

ENGINE—VALVE SYSTEM (cont.)

Timing	Intake	Opens (°BTC)	.001 LIFT	36°		
		Closes (°ABC)	.001 LIFT	108°	MAX LIFT 116° ATC *	
	Exhaust	Opens (°BBC)	.001 LIFT	86°		
		Closes (°ATC)	.001 LIFT	58°	MAX LIFT 114° BTC *	
Intake	Material		3140 STEEL (RICH) 8645 STEEL (EATON)			
	Overall length		4.675			
	Actual overall head dia.		1.875			
	Angle of seat		44°			
	Seat insert material		NONE			
	Stem diameter		.3415 - .3425			
	Stem to guide clearance		.0005 - .0025			
	Lift		.451			
	Outer spring press. and length	Valve closed (lb. @ in.)	60-65 @ 1.946			
		Valve open (lb. @ in.)	155-165 @ 1.496			
	Inner spring press. and length	Valve closed (lb. @ in.)	NONE			
		Valve open (lb. @ in.)	---			
	Exhaust	Material		81940 (EATON) 82120 HEAD 8729 STEM (RICH)		
		Overall length		4.692		
Actual overall head dia.		1.437				
Angle of seat		44°				
Seat insert material		NONE				
Stem diameter		.3415 - .3420				
Stem to guide clearance		.001 - .0025				
Lift		.451				
Outer spring press. and length		Valve closed (lb. @ in.)	60-65 @ 1.946			
		Valve open (lb. @ in.)	155-165 @ 1.496			
Inner spring press. and length		Valve closed (lb. @ in.)	NONE			
		Valve open (lb. @ in.)	---			

ENGINE—LUBRICATION SYSTEM

Type of lubrication (splash, pressure, nozzle)	Main bearings	PRESSURE
	Connecting rods	"
	Piston pins	SPLASH
	Camshaft bearings	PRESSURE
	Tappets	"
	Timing gear or chain	METERED CENTRIFUGAL FLOW
	Cylinder walls	INTERMITTENT JET

*NEW CONDITION ONLY

AMA Consolidated Specification Questionnaire

MAKE OF CAR CADILLAC MODEL YEAR 1957

MODEL _____ ALL _____

ENGINE—LUBRICATION SYSTEM (cont.)

Oil pump type	GEAR
Normal oil pressure (lb. @ rpm)	30-35 @ 30 MPH
Oil pressure gage type (electric or mechanical)	ELECTRIC TELL TALE
Type oil intake (floating, stationary)	FLOATING
Oil filter type (full flow, partial flow)	PARTIAL FLOW
Capacity of crankcase, less filter—refill (qt.)	5 QT. + 1 QT. OIL FILTER
Oil grade recommended (SAE viscosity and temperature range)	+32°F 20W OR SAE 20
	+10°F 20W
	-10°F 10W
	BELOW -10°F 5W
Oil type recommended	FOR SERVICED MS OR DG.

ENGINE—FUEL SYSTEM

Recommended fuel	Standard head	PREMIUM	
	Optional head	NONE	
Fuel Tank	Capacity (gals.)	20	
	Filler Location	LEFT HAND TAIL LAMP	
Fuel Filter	Type	A. C.	
	Location	RIGHT HAND FRONT OF ENGINE	
Fuel pump	Type (elec. or mech.)	MECHANICAL	
	Location	TOP RIGHT FRONT	
	Pressure range	5.25 - 6.50 PSI @ 1800 RPM PUMP SPEED	
	Vacuum booster (std., optl., none)	STD (ON OIL PUMP)	
Carburetor	Make	CARTER AND ROCHESTER PRODUCTS	
	Model number	*CARTER 24795 ROCHESTER 7010100 **	
	Number used	1, 2 ON OPT Q ENGINE	
	Type	Downdraft, side inlet, other	DOWN DRAFT - TOP INLET
		Single or dual	4 BARREL
	Intake manifold heat control (manual, auto., none)		AUTOMATIC
	Automatic choke type (integral, other)		INTEGRAL
	Air cleaner type	Standard	A. C. OIL BATH
Optional		NONE	

ENGINE—EXHAUST SYSTEM

Type (single, single with cross-over, dual, other)	DUAL	
Muffler type (rev. flow, str. thru, sep. resonator)	REVERSE FLOW MUFFLERS AND RESONATORS	
Exhaust pipe dia.	XXXX FRONT	2.00
	XXXX INTERMEDIATE	1.75
Tail pipe diameter	1.75	

** A./C.
CARTER 24808
ROCHESTER 7010101

* Q ENGINE INSTALLATION ONLY
F. R.
CARTER 25825 25835
ROCHESTER 7010302 7010300

AMA Consolidated Specification Questionnaire

MAKE OF CAR	CADILLAC	MODEL YEAR	1957
MODEL	60 & 62		75

ENGINE—COOLING SYSTEM

Type (pressure system, atmospheric, other)		PRESSURE	
Radiator cap relief valve press.		12-15 LBS.	
Circulation thermostat	Type (choke, bypass)	CHOKE	
	Starts to open at	163° - 168°	
Water pump	Type (centrifugal, other)	CENTRIFUGAL DUAL OUTLET	
	Number of pumps	1	
	Drive (V-belt, other)	V BELT	
	Bearing type	DOUBLE ROW BALL BEARING	
By-pass recirculation type (internal, external)		INTERNAL	
Radiator core type (cellular, tube and fin)		TUBE & CENTER	
Cooling system capacity	With heater (qt.)	20.5	21.5
	Without heater (qt.)	19.5	19.5
Water jackets full length of cylinder (yes, no)		YES	
Water all around cylinder (yes, no)		YES	
Radiator hose	Lower	Number and type (molded, straight)	1 - MOULDED
		Inside diameter and length	1.75X 10.75
	Upper	Number and type (molded, straight)	1 - MOULDED
		Inside diameter and length	1.75X 10 25
	By-pass	Number and type (molded, straight)	NONE
		Inside diameter and length	NONE
Drive belts	Fan	Number used	1
		Angle of V	40°
		Outside length	57.24"
		Width	.380
	Generator	Angle of V	SAME AS FAN
		Outside length	"
		Width	"
Fan	Number of blades and spacing	* 4 @ 76	6 @ 50°-54°
	Diameter	18.25	
	Ratio—fan to crankshaft revolutions	.95 TO 1	
	Bearing type	NONE	

* A/C FAN 6 @ 50°-54° ON 60 & 62

AMA Consolidated Specification Questionnaire

MAKE OF CAR CADILLAC MODEL YEAR 1957

MODEL ALL

ELECTRICAL—SUPPLY SYSTEM

Battery	Make and Model		DELCO REMY
	Voltage Rtg. & Plates/cell		12 VOLT - 11 PLATE 3 FMR 70-W
	SAE Designation & Amp Hr. Rtg		70 AMP HRS @ 20 HRS
	Location		UNDER HOOD ON TRAY ATTACHED TO RAD. CRADLE
Terminal grounded		NEGATIVE	
Generator	Make		DELCO REMY
	Model		* 1102086 - 35 AMP
	Type		2 POLE GEN.
	Ratio—Gen. to Cr/s rev.		2.15:1
Regulator	Make		DELCO REMY
	Model		** 1119002 - 35 AMP
	Type		CURRENT & VOLTAGE 1119163 40 AMP
	Cutout relay	Closing voltage @ generator rpm	11.0 - 13.6 ADJ. 12.8
		Reverse current to open	.0-4
	Regulated	Voltage	14.0 - 15.0 ADJ. 14.5
		Current	N. A.
	Min. Gen. rpm required		2150
	Voltage test conditions	Temperature	N. A.
		Load	N. A.
Other		N. A.	

ELECTRICAL—STARTING SYSTEM

Starting motor	Make		DELCO REMY
	Model		1107657
	Rotation (drive end view)		CLOCKWISE
	Engine cranking speed		
	Test conditions		N. A.
	Lock test	Amps	395 AMPS MAX.
		Volts	3.5 VOLTS MAX.
		Torque (lb. ft.)	--
	No load test	Amps	91 AMPS
		Volts	10.6
RPM (min.)		3900	
Motor control	Switch (solenoid, manual)		SOLENOID
	Starting procedure		COLD START - DEPRESS ALL THE WAY AND REMOVE FOOT TURN IGNITION KEY TO FULL RIGHT POSITION TO START. WARM START - DEPRESS ACCELERATOR PEDAL HALF WAY HOLD UNTIL ENGINE STARTS.

* 1102060 40 AMP ON 75 A/C
** 1119162 40 AMP ON 75 A/C

AMA Consolidated Specification Questionnaire

MAKE OF CAR CADILLAC **MODEL YEAR** 1957

MODEL ALL

ELECTRICAL—STARTING SYSTEM (cont.)

Motor drive	Engagement type	SPIRAL SPLINE & OVER RUNNING CLUTCH		
	Pinion meshes (front, rear)	FRONT		
	Number of teeth	Pinion	9	
		Flywheel	176	
	Flywheel tooth face width	.500		

ELECTRICAL—IGNITION SYSTEM

Coil	Make	DELCO REMY		
	Model	1115082		
	Amps	Engine stopped	3.0	
Engine idling		1.25		
Distributor	Make	DELCO REMY		
	Model	1110376		
	Spark advance data (at distributor shaft)	Centr. advance start (rpm)	150-400	
		Centr. advance max. deg. @ rpm	22°-26 @ 4140 RPM	
		Vacuum advance start (in. Hg.)	8.0-10.0 IN. H. G.	
		Vac. adv. (max. deg. @ in. Hg.)	22.5-25.5 @ 13.5-15.25 IN. H. G.	
	Breaker gap (in.)	.016-.021 ORIGINAL - .016 SERVICE		
	Cam angle (deg.)	31° + 1.50°		
	Breaker arm tension (oz.)	19-23 OZ		
C/S deg. @ rpm	5° @ 400 RPM WITH VACUUM ADVANCE PIPE DISCONNECTED			
Timing	Mark location	CRANKSHAFT BALANCER		
	Cylinder numbering system (see page 2)	L - 1-3-5-7	R - 2-4-6-8	
		Firing order (see page 2)	1-8-4-3-6-5-7-2	
Spark plug	Make and model	AC - 44		
	Thread (mm)	14		
	Tightening torque (lb. ft.)	20-25		
	Gap	.035		
Cable	Conductor type	7 MM		
	Insulation type	NEOPRENE		
	Spark plug protector	"		

ELECTRICAL—SUPPRESSION

Description	DIST. ROTOR GEN. COND. COIL COND. REG. COND.
	10,000 OHM RESISTOR .3MFD ON GEN. (ARM TERM.) .3MFD ON COIL (FEED TERM.) .5MFD ON BATTERY TERM. OF REG.

2 ENGINE GROUND STRAPS FROM BACK OF EACH HEAD TO DASH.

AMA Consolidated Specification Questionnaire

MAKE OF CAR CADILLAC **MODEL YEAR** 1957

MODEL ALL

ELECTRICAL—INSTRUMENTS AND SWITCHES

Speed-ometer	Make Trip odometer (yes, no)	A. C. YES
Charge indicator—type		TELL TALE LIGHT
Temperature indicator—type		ELECTRIC INDICATOR
Oil pressure indicator—type		TELL TALE LIGHT
Fuel indicator—type		ELECTRIC INDICATOR
Ignition switch	Identify positions in order and circuits controlled	AT 12 O'CLOCK IGN OFF CLOCKWISE 1ST POSITION ALL CIRCUITS ON 2ND POSITION IGN AND STARTER CIRUCITS ON COUNTER CLOCKWISE COUNTER CLOCKWISE 1ST POSITION ALL ACCESSORIES ONLY
	Provision for illumination	YES
	Location	RIGHT SIDE OF STEERING COLUMN IN INSTRUMENT PANEL
	Theft protection type	NO
Main lighting switch	Identify positions and lights controlled	PULL OUT - 1st POSITION PARK OR FOG - INST. - TAIL 2nd POSITION FULL OUT - INST. - HEAD & TAIL LIGHTS RHEOSTAT - CLOCKWISE TO DECREASE INTENSITY OF INSTRUMENT LIGHTS
Other light switches	Locations and lamps controlled	FOG LIGHT SWITCH MOUNTED TO MAIN LIGHT SWITCH CONTROLLED BY SECONDARY RING KNOB. SELECTS PARKING OR FOG LAMPS WHEN HEAD LIGHT SWITCH IS IN POSITION. FRONT DOOR SWITCH - MAP AND COURTESY LIGHTS ON PANEL SEDANS. DOME ON COUPES. REAR DOOR SWITCH - DOME - SEDANS ONLY. REAR DOOR PILLARS - 75 SERIES DOME AND COURTESY. LEFT CENTER PILLAR - SEDANS ONLY. REAR QUARTER PANEL CONV. SEAT.BACK LIGHTS.
Other switches	Locations and devices controlled	SIDE DOME- SWITCH - COUPE DEVILLE - LEFT QUARTER ARM REST. GLOVE BOX LIGHT - UPPER LEFT HAND CORNER OF DOOR. BRAKE LIGHT SWITCH - LOCATED ON BRAKE LEVER LT. IN INST. CLUSTER. TURN SIGNAL SWITCH - IN STEERING COLUMN. HEATER SWITCH - INST* PANEL. RADIO - SWITCH - INTEGRAL PART OF VOLUMN CONTROL ON RADIO.
Windshield wiper	Make	TRICO
	Type	VACUUM
	Vacuum booster provision	YES
	Washer provision	YES
Horn	Type	VIBRATOR
	Number used	TWO
	Amp draw (each)	LOW 10.5 HIGH 10.5

AMA Consolidated Specification Questionnaire

MAKE OF CAR	CADILLAC	MODEL YEAR	1957
MODEL	ALL		

ELECTRICAL—LAMP BULBS

Give quantity used and trade number, e.g., Headlamp 2-4030.
Indicate accessories which are not standard equipment by an asterisk following the numbers.

Headlamp		2- SEALED BEAM UNIT	
Headlamp beam indicator		1- 57	
Parking light		2- 67	
Tail light		2- 1034 - 32 - 4 C.P.	
Stop light		2- 1034 - 32 - 4 C.P.	
Direction indicator	Front	2- 1034 - 32 - 4 C.P.	
	Rear	2- 1034 - 32 - 4 C.P.	
	Tell-Tale	2- 57 - 2 C.P.	
License plate light		1- 67 - 3 C.P.	
Instrument light		4- 57 - 2 C.P.	
Ignition lock light		1- 53 - 1 C.P.	
Map light		1- 90 - 6 C.P.	
Dome light		1- 1004 - 15 C.P.	
Clock light		2- 57 - 2 C.P.	1 ON 60 SERIES
Radio dial light		1- 1891 - 2 C.P.	
Glove compartment light		1- 57 - 6 C.P.	
Courtesy light		1- 90 - 6 C.P.	
Trunk compartment light		1- 89 - 6 C.P.	
Other	OIL TELL TAIL	1-57 2 C.P.	HYD. SHIFT IND. 1- 57 - 1 C.P.
	GEN. TELL TAIL	1-57 2 C.P.	BACK UP LIGHTS 2- 1034 - 4 C.P.
	HAND BRAKE TELL TAIL	1-57 2 C.P.	ASH TRAY LIGHTS 2- 53 - 1 C.P.
	SEAT BACK LIGHT	2-90 6 C.P.	
	CORNER LAMP	2- 90 6 C.P. ON 7523-33	

ELECTRICAL—FUSE & CIRCUIT BREAKER DATA

Use trade number of fuse, e.g., SFE-10. Indicate circuit breaker by ampere capacity suffixed by letters "C.B.", e.g., 30 C.B. Where fuse or circuit breaker protects multiple circuits indicate first use by a letter and repeat the same letter for all units protected by the same fuse or circuit breaker, e.g., Parking light: SFE-10 (a), Direction Indicator: same as (a).

Headlamp		20 ACB - LIGHT SWITCH	
Headlamp beam indicator		"	
Parking light		"	
Tail light		"	
Stop light		"	
Direction indicator		6A - SFE FUSE ON DASH INSIDE CAR	
License plate light		20 ACB	
Instrument light		"	
Ignition light		"	
Map light		"	
Dome light		25 AGC FUSE ON DASH	
Clock		25 AGC	
Clock light		20 ACB	
Radio		7.5A ABA	
Glove compartment light		25 AGC	
Courtesy light		20 ACB	
Trunk compartment light		25 AGC	
Other	BACK-UP	9A-AFE	ELECTRIC WINDOW & SEATS 40 ACB
	HEATER	20A-AGC	FRONT CIGAR LIGHTERS (2) 25A AGC
	A. C.	20A AGC	INSTRUMENT CIRCUIT 9A SFE
	BODY FEED	25A AGC	AUTO. DECK LID 5A CB
	FOG LIGHT	9A	ELECTRIC ANT 9A

AMA Consolidated Specification Questionnaire

MAKE OF CAR CADILLAC **MODEL YEAR** 1957

MODEL ALL

DRIVE UNITS—CLUTCH (PEDAL OPERATED)

Make		N. A.	
Type (dry or wet plate)			
In combination with fluid coupling (yes, no)			
Semi-centrifugal (yes, no)			
Type pressure plate springs			
Total plate pressure (lb.)			
No. of clutch driven discs			
Clutch facing	Material		
	Inside diameter		
	Outside diameter		
	Total eff. area (sq. in.)		
	Thickness		
	Number required		
	Engagement cushioning method		
	Release bearing	Type	
		Method of lubrication	
	Torsional damping	Method (springs, other)	
Frict. mat.			

DRIVE UNITS—TRANSMISSIONS

Conventional (std. or opt.)	N. A.
Conventional with overdrive (std. or opt.)	N. A.
Automatic (std. or opt.)	STD.

DRIVE UNITS—CONVENTIONAL TRANSMISSION

Number of forward speeds		N. A.
Transmission ratios	In first	
	In second	
	In third	
	In fourth	
	In reverse	
Constant mesh gears in 2nd (yes, no)		
Spur gear used in (indicate speeds)		
Helical gears used in (indicate speeds)		
Synchronous meshing in 2nd and 3rd gears (yes, no)		

AMA Consolidated Specification Questionnaire

MAKE OF CAR CADILLAC **MODEL YEAR** 1957

MODEL ALL

DRIVE UNITS—CONVENTIONAL TRANSMISSION (cont.)

Lubricant	Capacity (pt.)	N. A.		
	Type recommended			
	SAE viscosity number	Summer		
		Winter		
	Extreme cold			

DRIVE UNITS—CONVENTIONAL TRANSMISSION WITH OVERDRIVE

For transmission data see conventional transmission section

Overdrive	Type (planetary or other)		N. A.	
	If planetary, No. of pinions			
	Manual lockout (yes, no)			
	Downshift accelerator control (yes, no)			
	Minimum cut-in speed			
	Gear ratio			
	Lubri- cant	Capacity (O.D. only)		
		Separate filter (yes, no)		
		Type recommended		
		SAE viscosity number	Summer	
Winter				
	Ext. cold			

DRIVE UNITS—AUTOMATIC TRANSMISSION

Trade name	HYDRAMATIC CONTROLLED COUPLING
Type (fluid coupling with gears, torque convertor with gears, other)	FLUID COUPLING WITH GEARS
Manual selector positions, left to right (show symbols and define, e.g., N- Neutral)	P. PARK N. NEUTRAL D.R. 1ST POSITION - (1-2-3-4) SHIFT 2ND POSITION - (1-2-3) SHIFT LO. LOW RANGE R. REVERSE
List gear ratios in each drive position (range)	LOW 3.9666 SECOND 2.5532 THIRD 1.5536 FORTH 1.0000 REVERSE 3.7400
Shifting within drive position range by accelerator control and speed limiting governor (yes, no)	YES
By governor—forced shift (yes, no)	YES
Downshift of gears in high range possible up to (mph)	4-3 TO APPROX. 70 MPH - 3 - 2 TO APPROX. 25 MPH

AMA Consolidated Specification Questionnaire

MAKE OF CAR	CADO:AC	MODEL YEAR	1957
MODEL	60-62		75

DRIVE UNITS—AUTOMATIC TRANSMISSION (cont.)

Torque convertor	Number of elements	N. A.	
	Max. ratio at stall at engine rpm		
	Mechanical lockup	Provided (yes, no)	
		Speed range	
		Releases at (speed range, mph)	
	Type of cooling (forced air, oil cooler and type, other)	OIL COOLER	
Anti-creep device (yes, no)	NO		
Lubricant	Capacity—refill (pt.)	11.0 QTS.	
	Type recommended	AUTOMATIC TRANS. FLUID TYPE A-AQ OR CADILLAC HYD. FLUID	
	Grade	Summer	-
		Winter	-
		Extreme cold	-

DRIVE UNITS—PROPELLER SHAFT

	Number used	2	
	Type (exposed, torque tube)	EXPOSED	
Outer diameter x length* x wall thickness	Conventional trans.	N. A.	
	Overdrive trans.	N. A.	
	Automatic trans.	**	
Intermediate bearing	Type (plain, anti-friction)	ANTI FRICTION	
	Lubri. (fitting, prepack)	PRE PACKED	
Universal joints	Make	MECHANICS AND SAGINAW	
	Number used	3 3	
	Type (ball and trunion, cross, other)	CROSS AND TRUNNION	
	Bearing	Type (plain, anti-friction)	NEEDLE
		Lubric. (fitting, prepack)	PRE PACKED
	Drive taken through (torque tube or arms, spring)	SPRINGS	
	Torque taken through (torque tube or arms, springs)	SPRINGS	

*Centerline to centerline of joints or centerline of rear attachment point.

** 62 2.25 x 28.65 x .095 FRONT SHAFT
2.25 x 32.04 x .095 REAR SHAFT

60 2.25 x 28.65 x .095 FRONT SHAFT
2.25 x 35.52 x .095 REAR SHAFT

75 2.25 x 39.99 x .095 FRONT SHAFT
2.25 x 41.00 x .095 REAR SHAFT

AMA Consolidated Specification Questionnaire

MAKE OF CAR CADILLAC **MODEL YEAR** 1957

MODEL 60-62 75

DRIVE UNITS—REAR AXLE

Type (semi-floating, other)		SEMI FLOATING		
Gear type (hypoid, other)		HYPOID		
Gear ratio and No. of teeth	Conventional trans.	N. A.		
	Overdrive trans.	N. A.		
	Automatic trans.	*3.07	3.36	
Pinion adjustment (shim, other)		NONE		
Pinion bearing adj. (shim, other)		COLLAPSABLE SPACER		
Lubricant	Capacity (pt.)	5 PTS		
	Type recommended	G. M. 4655 M. HYPOID LUB.		
	SAE viscosity number	Summer	90	
		Winter	90	
		Extreme cold	80	

DRIVE UNITS—WHEELS

Type (disc, other)		** SLOTTED STEEL DISC.	
Rim (size and flange type)		15 x 6L	
Attachment	Type (bolt or stud)	STUD	
	Circle diameter	5"	
	Number and size	5 1/2-20	

DRIVE UNITS—TIRES

Size and ply rating	Standard	8.00 x 15 - 4 PLY RATING BLACK	8.20 x 15 - 6 PLY RATING BLACK
	Optional	8.20 x 15 - 4 PLY RATING WHITE	8.20 x 15 - 6 PLY RATING WHITE
Rev/mile at 30 mph		***	***
Inflation press. (cold)	Front	24	28
	Rear	24	28

BRAKES—SERVICE

Type		HYDRAULIC DUO SERVO	
Booster type		BENDIX TWO STAGE HYDRAULIC	
Effective area (sq. in.)		210.32	233.72
Percent brake effectiveness—rear			
Drum	Diameter	Front	12"
		Rear	12"
	Type and material		COMPOSITE RIBBED CAST IRON

*3.36:1 RATIO OPTIONAL ON 60 AND 62 SERIES EXCEPT STD. ON ALL Q ENGINE EQUIPPED CARS

3.77:1 RATIO OPTIONAL ON ALL 75

**EXCEPT ELD. USES SABRE - SPOKE WHEELS

60 AND 62 SERIES

75 SERIES

	<u>820 x 15</u>	<u>800 x 15</u>	<u>820 x 15</u>
*** FIRESTONE TUBLESS	706	711	706
US ROYAL "	712	720	712
GOODRICH "	706	717	706

AMA Consolidated Specification Questionnaire

MAKE OF CAR CADILLAC **MODEL YEAR** 1957

MODEL 60-62 75

BRAKES—SERVICE (cont.)

	Bonded or riveted			RIVETED	
	Brake lining	Primary	Material		MOULDED ASBESTOS
Size (length x width x thickness)			Front wheel	10.05 x 2.5 x .25	12.98 x 2.5 x .275
			Rear wheel	10.05 x 2.5 x .25	12.98 x 2.5 x .275
Segments per shoe			1		
Secondary		Material		MOULDED ASBESTOS	
		Size (length x width x thickness)	Front wheel	12.98 x 2.5 x .275	
			Rear wheel	12.98 x 2.5 x .275	
		Segments per shoe		1	
Wheel cylinder bore	Front	1.12			
	Rear	1"			
Master cylinder bore		.656			
Available pedal travel		4.5			
Line pressure at 100 lb. pedal load		930 PSI			
Shoe clearance adjustment		.010 TOP .015 BOTTOM			

BRAKES—PARKING

Type of control		FOOT OPERATED
Location of control		LEFT OF STEERING COLUMN
Operates on		REAR SERVICE BRAKES
If separate from service brakes	Type (internal or external)	NONE
	Drum diameter	-
	Lining size (length x width x thickness)	-

FRAME

Type and description	TUBULAR CENTER X FRAME
----------------------	------------------------

FRONT SUSPENSION

Type and description	INDEPENDENT COIL SUSPENSION
----------------------	-----------------------------

AMA Consolidated Specification Questionnaire

MAKE OF CAR CADILLAC MODEL YEAR 1957

MODEL ALL

FRONT SUSPENSION (cont.)

	Type	COIL			
	Material	9260 STEEL			
Spring	Size (length x width x No. leaves or coil I.D.)	(1) 17.06 x 4	(2) 16.88 x 4	(3) 16.62 x 4	(4) 16.50 x 4
	Spring rate (lb. per in.)	350 (1)	375 (2)	400 (3)	475 (4)
	Rate at wheel (lb. per in.)				
	Normal load (lb. @ rated length)	(1) 2400 @ 10.04	(2) 2500 @ 10.04	(3) 2550 @ 10.04	(4) 2800 @ 10.50
Shock absorbers	Manufacturer	DELCO PRODUCTS			
	Type (direct or lever)	HYDRAULIC DIRECT ACTING			
	Piston diameter	1"			
Stabilizer	Type (link, linkless, frameless)	LINK			
	Material	STEEL			

STEERING

Type used (Standard or optional)		Mechanical	N. A.		
		Power	STANDARD		
Wheel diameter		18"			
Turning diameter	Outside front	Wall to wall (r. & l.)			
		Curb to curb (r. & l.)			
	Inside rear	Wall to wall (r. & l.)	-		
		Curb to curb (r. & l.)	-		
Inside wheel angle with outside wheel at 20°		22° 40'			
Mechanical	Gear	Type	N. A.		
		Make			
		Ratios	Gear	Overall	
	No. wheel turns				
Power	Type	HYDRAULIC POWER			
	Make	SAGINAW			
	Trade name	CADILLAC POWER STEERING			
	Gear	Type	BALL NUT & SECTOR		
		Ratios	Gear	Overall	
		Pump driven by		**	BELT
	Overall torque ratio		118:1 (AT PARKING)		
	Number wheel turns		4.0		
Linkage	Type	PARALLEL DRAG LINK			
	Location (front or rear of wheels)	REAR			
	Drag link (trans. or long)	TRANSVERSE			
	Tie rods (one or two)	TWO			

1. 6237 - 370 - 39 - 390
2. 6039 - 6267 - 375
3. 6267S
4. 7523 - 33

** POWER STEERING BELT 40" - 37" O. L. .380 W.

AMA Consolidated Specification Questionnaire

MAKE OF CAR CADILLAC **MODEL YEAR** 1957

MODEL 60-62 75

STEERING (cont.)

STEERING AXIS	Inclination at camber (deg.)		4° @ 0 CAMBER	
	Diameter		SPHERICAL JOINTS	
	Bearings (type)	Upper	"	"
		Lower	"	"
Thrust		"	"	
Wheel alignment (range and preferred)	Caster (deg.)		-1/2° TO -1 1/2° -1° PREFERRED	
	Camber (deg.)		-0.375° - +0.375° *	
	Toe-in (outside tread- inches)		.156-.218 .187 PREFERRED	
Steering knuckle type				
Wheel spindle	Diameter	Inner bearing	2.9630	
		Outer bearing	2.25	
	Thread size		.75 - 20 NS-3	
	Bearing type		BALL	

REAR SUSPENSION

Type		LEAF					
Drive and torq. taken through (see page 14)		REAR SPRINGS					
Spring	Type		SEMI ELLIPTIC				
	Material		SAE 5155 STEEL				
	Size (length x width x No. leaves or coil I.D.)		(1) (2) (3) (4)				(5)
			56.5 x 2.5 x 5				56.5 x 2.5 x 6
	Spring rate (lb. per in.)		120 (1)	115 (2)	130 (3)	125 (4)	150 (5)
	Rate at wheel (lb. per in.)						
	Normal load (lb. at rated length)		(1)	(2)	(3)	(4)	(5)
			1225 @ - .09	1175 @ - .09	1200 @ - .09	1250 @ - .09	1425 @ + .79
	Mounting insulation type		RUBBER				
	If leaf	No. of leaves		5			6
		Covers (yes, no)		NO			
Lubricated (yes, no)		NO					
Inserts		Type and size		FULL LENGTH			
	Material		WAX IMPREGNATED				
Shackle (comp. or tens.)		COMPRESSION LINK					
Shock absorbers	Manufacturer		DELCO				
	Type (direct or lever)		HYDRAULIC DIRECT ACTING				
	Piston diameter		1.0"				
Stabilizer	Type (link, linkless, frameless)		NONE				
	Material		"				
Track bar type		"					

1. 6039 - 6237S - 6267
2. 6237 - 370
3. 6239 - 390
4. 6267S
5. 7523-33

*LEFT SIDE TO BE +.25 TO +.50 GREATER THAN RIGHT SIDE

AMA Consolidated Specification Questionnaire

MAKE OF CAR CADILLAC MODEL YEAR 1957

BODY—GENERAL DEFINITIONS

NOTE: Included in the dimension definitions listed on this and the following pages are those which have been proposed for adoption by the SAE. These are indicated by a number following the type of dimension, e.g., L 3. Additional dimensions have been added by the AMA Specifications Body Sub-Committee for inclusion in the Questionnaire. These are shown by an additional letter, e.g., HA. The dimensions are developed from the following basic points:

1. Front and rear seat "A" points are taken 5" forward of vertical tangent to seat back 15" from center of body.
2. Front seat is in the rear position.
3. Loaded position—5 passengers, front 300 lb., rear 450 lb., includes spare wheel, tire and tools, and full complement of gas, oil, water, etc. and tires to recommended pressure, etc.
4. C. L. (centerline).
5. D. L. O. (daylight opening, exposed glass dimension).
6. Ramp breakover angle (page 20-A) is the supplement of the included ramp angle (180° minus the included ramp angle) over which a car can pass without hanging up.

MODEL	6239	6239D	6237	6237D	6267	6267S	6237S	6039	75
--------------	------	-------	------	-------	------	-------	-------	------	----

BODY—TRUNK OPENING DIMENSIONS

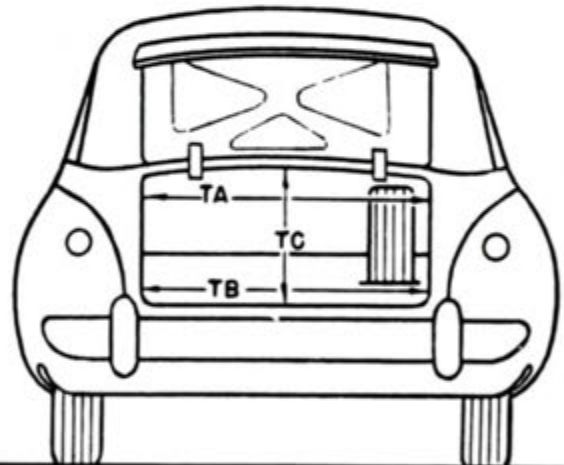
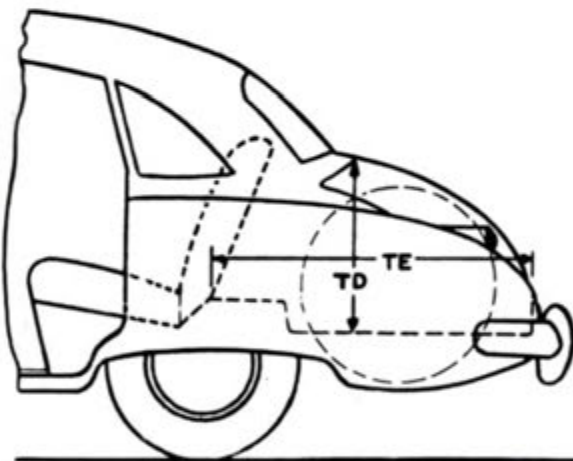

TA—Width across the top	52.8	52.8	52.8	52.8	52.8	52.8	48.7	52.8	52.8
TB—Width across the bottom	52.8	52.8	52.8	52.8	52.8	52.8	48.7	52.8	52.8
TC—Diagonal dimension at CL from top of opening to bottom	36.1	36.1	46.3	46.3	44.9	44.9	51.8	43.7	36.1
TD—Vertical height of opening (floor to top, inside edge of opening)	23.2	23.2	23.2	23.2	23.2	23.2	23.5	23.3	23.2
TE—Max. horizontal depth (forward from vertical projection of inside edge of opening)	49.1	49.1	60.1	60.1	60.8	60.8	66.6	57.5	49.1
Position of spare tire stowage	VERTICAL								
Method of holding lid open	TORSION BAR								

AMA Consolidated Specification Questionnaire

Page 20
Rev. 8-53

MAKE OF CAR CADILLAC MODEL YEAR 1957

MODEL	6239	6239D	6237	6237D	6267	6267S	6237S	6039	7523	7533
-------	------	-------	------	-------	------	-------	-------	------	------	------

BODY—HEIGHT DIMENSIONS—INTERIOR

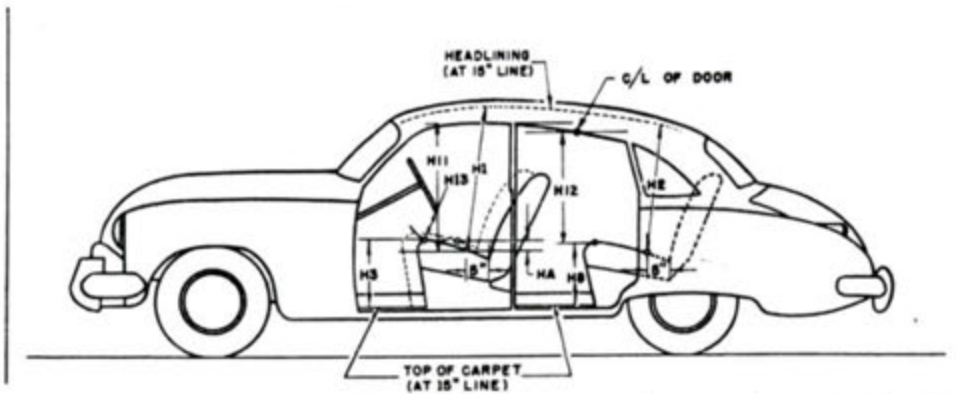

H1. Front headroom—from "A" pt. to headlining at 8° back of vertical on 15" line. (For "A" pt. see note 1, page 19)	*35.7 35.0	35.6 34.9	35.0 34.2	35.1 34.7	36.0 35.2	36.0	35.5	34.6 33.9	36.6	36.6
H2. Rear headroom—from "A" pt. to headlining at 8° back of vertical on 15" line.	34.9	34.9	34.0	34.0	34.7	34.7	34.0	34.7	35.3	35.3
H3. Front seat height to floor carpet on 15" line (front edge of cushion).	*12.8 13.5	12.8 13.5	12.1 12.9	12.1 12.9	12.1 12.9	12.2	12.2	13.1 13.9	12.8	12.8
H8. Rear seat height to floor carpet on 15" line (front edge of cushion).	12.7	12.7	13.7	13.7	13.7	13.4	13.4	12.7	13.6	13.6
H11. Entrance—front—cushion "A" point to bottom windcord vertical.	*29.4 28.4	29.4 28.4	28.9 28.1	28.9 28.1	28.9 28.1	29.0	29.0	29.0 28.0	32.2	32.2
H12. Entrance—rear—top of cushion to bottom windcord vertical at C/L of rear door.	28.2	28.2	-	-	-	-	-	28.2	Aux. 32.8	SEAT 32.8
H13. Steering wheel clearance to seat cushion taken on arc.	*5.5 4.8	5.5 4.8	6.1 5.4	6.1 5.4	6.1 5.4	6.1	6.1	5.2 4.4	5.5	5.5
HA. Front seat vertical rise at "A" pt. (inches.)	N. A.									

* SEAT SHIMS REMOVED

AMA Consolidated Specification Questionnaire

MAKE OF CAR CADILLAC MODEL YEAR 1957

MODEL	6239	6239D	6237	6237D	6267	6267S	6237S	6039	7523	7533
--------------	------	-------	------	-------	------	-------	-------	------	------	------

BODY—HEIGHT DIMENSIONS—EXTERIOR

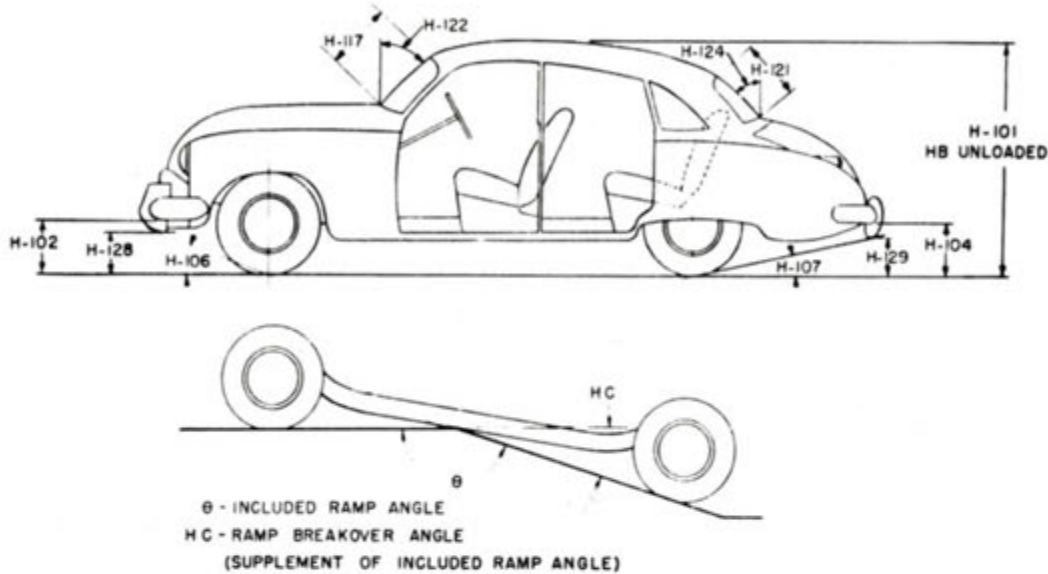

H101. Overall height.	59.1	59.1	57.7	57.7	58.2	58.4	57.9	59.1	61.6	61.6
HB. Overall height—unloaded.	61.0	61.0	59.6	59.6	60.0	60.2	59.8	61.0	63.7	63.7
H102. Front bumper bottom to ground at normal section.	9.0	9.0	9.0	9.0	9.0	9.2	9.2	9.0	10.1	10.1
H104. Rear bumper bottom to ground at normal section.	10.7	10.7	10.7	10.7	10.7	10.9	10.9	10.7	11.8	11.8
H106. Angle of approach—from the tire rolling radius to lowest point on front bumper or guard.	23°4'	23°4'	23°4'	23°4'	23°4'	23°5'	23°5'	23°4'	25°28'	25°28'
H107. Angle of departure—from the tire rolling radius to lowest point on rear bumper or guard.	14°6'	14°6'	12°46'	12°46'	12°46'	13°46'	13°46'	12°46'	15°24'	15°24'
HC. Ramp breakover angle.*	12°14'	12°14'	12°14'	12°14'	12°14'	13°50'	12°13'	11°54'	12°2'	12°2'
H117. Windshield DLO—slant height.	N. A.									
H121. Backlight DLO*—Max., slant height.	N. A.									
H122. Windshield slope angle to vertical line on car axis.	47°	47°	47°	47°	47°	47°	47°	47°	47°	47°
H124. Backlight slope angle to vertical line on car axis.	N. A.									
H128. Ground to bottom of front bumper guard.	21.2	21.2	21.2	21.2	21.2	21.4	21.4	21.2	22.3	22.3
H129. Ground to bottom of rear bumper guard.	10.5	10.5	10.5	10.5	10.5	10.7	10.7	10.5	11.6	11.6
HD. Min. road clearance (location and dimension). **	6.2	6.2	6.2	6.2	6.2	6.4	6.4	6.2	7.2	7.2
HE. Min. road clearance at rear axle.	7.9	7.9	7.9	7.9	7.9	8.1	8.1	7.9	7.9	7.9

*See Notes, page 19.

** EXHAUST SYSTEM MUFFLER

AMA Consolidated Specification Questionnaire

MAKE OF CAR CADILLAC MODEL YEAR 1957

MODEL	6239	6239D	6237	6237D	6267	6267S	6237S	6039	7523	7533
-------	------	-------	------	-------	------	-------	-------	------	------	------

BODY—LENGTH DIMENSIONS

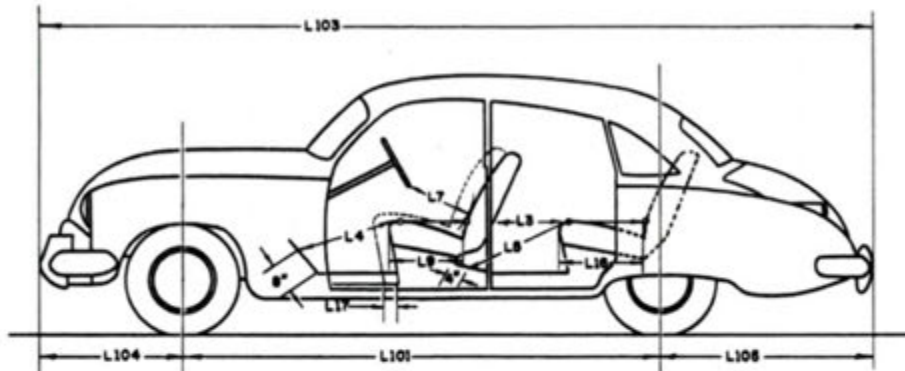

Interior	L3. Rear compartment back of front seat back to rear seat back.	*34.7 34.2	34.7 34.2	29.5 29.4	29.5 29.4	29.4 29.2	29.4 29.4	29.5 29.5	34.7 34.2	26.8 26.8	26.8 26.8	
	L4. Leg room—front—diagonal—ball of foot to top of seat to front seat back—15° line.	*44.9 45.0	44.9 45.0	44.4 44.6	44.4 44.6	44.4 44.6	44.5 44.5	44.5 44.5	44.8 45.2	43.5 43.5	43.5 43.5	
	L5. Leg room—rear—diagonal— from ball of foot to top of rear seat cushion and to seat back.	*44.3 45.2	44.3 45.2	40.3 41.0	40.3 41.0	40.2 40.9	40.3 40.3	40.4 40.4	44.4 45.3	- -	- -	
	L7. Steering wheel clearance to seat back taken on arc.	*15.2 15.0	15.2 15.0	15.3 15.1	15.3 15.1	15.3 15.1	15.3 15.3	15.3 15.3	15.2 15.0	14.1 14.1	14.1 14.1	
	L9. Front seat depth (front edge to vert. tan. to seat back on 15° line).	17.8	17.8	17.8	17.8	17.8	17.8	17.8	17.8	18.1	18.1	
	L16. Depth of rear seat (front edge to seat back).	18.6	18.6	18.5	18.5	18.5	18.5	18.5	18.5	18.6	18.2	18.2
	L17. Total adjustment of front seat at floor.	N. A.										
Exterior	L101. Wheel base.	129.5	129.5	129.5	129.5	129.5	129.5	129.5	133.0	149.8	149.8	
	L103. Overall length (bumper to bumper inc. guards).	215.9	215.9	220.9	220.9	220.9	222.1	222.1	224.4	236.2	236.2	
	L104. Overhang—front including bumper guards.	34.7	34.7	34.7	34.7	34.7	34.7	34.7	34.7	34.7	34.7	
	L105. Overhang—rear including bumper guards.	51.7	51.7	56.7	56.7	56.7	57.9	57.9	56.7	51.7	51.7	

* SEAT SHIMS REMOVED

AMA Consolidated Specification Questionnaire

MAKE OF CAR CADILLAC **MODEL YEAR** 1957

MODEL	6239	6239D	6237	6237D	6267	6267S	6237S	6039	7523	7533
--------------	------	-------	------	-------	------	-------	-------	------	------	------

BODY—WIDTH DIMENSIONS

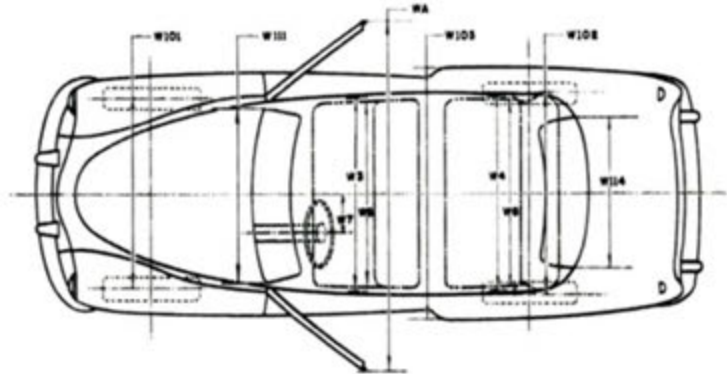

Interior	W3. Front shoulder room, at garnish moulding height or nearest interference 5" forward of seat back.	59.0	59.0	59.1	59.1	59.1	59.3	59.3	59.0	59.0	59.0
	W4. Rear shoulder room, at garnish moulding height or nearest interference 5" forward of seat back.	57.0	57.0	57.0	57.0	48.4	48.4	57.0	57.0	56.8	56.8
	W5. Front hip room, at top of seat 5" forward of vert. tan. to seat back.	65.4 65.2	65.4 65.2	65.8 65.6	65.8 65.6	65.8 65.6	65.7 65.7	65.7 65.7	65.2 65.0	65.5	65.5
	W6. Rear hip room, at top of seat 5" forward of vert. tan. to seat back.	65.0	65.0	57.3	57.3	52.2	52.2	57.3	65.0	57.8	57.8
	W7. Steering wheel center to center of body.	16.0	16.0	16.0	16.0	16.0	16.0	16.0	16.0	16.0	16.0
Exterior	W101. Front tread at ground.	61.0	61.0	61.0	61.0	61.0	61.0	61.0	61.0	61.0	61.0
	W102. Rear tread at ground.	61.0	61.0	61.0	61.0	61.0	61.0	61.0	61.0	61.0	61.0
	W103. Max. overall width of car including bumpers or mouldings.	80.0	80.0	80.0	80.0	80.0	80.0	80.0	80.0	80.0	80.0
	WA. Max. overall width of car with doors open.	153.5	153.4	161.3	161.3	161.3	161.3	161.3	153.4	153.5	153.5
	W111. Windshield DLO, max. width.	N. A.									
	W114. Back window DLO, max. width.	N. A.									

* SEAT SHIMS REMOVED

AMA Consolidated Specification Questionnaire

MAKE OF CAR CADILLAC **MODEL YEAR** 1957

MODEL	6237-390-6237S	6267-67S	6039-6239-390	7523-33
--------------	----------------	----------	---------------	---------

BODY—MISCELLANEOUS INFORMATION

Doors hinged (front, rear)	Front				FRONT
	Rear				FRONT
Type of finish (lacquer, enamel)				LAQUER	
Hood opening (front, side; semi-full, full, half)				FRONT	
Hood counterbalanced (yes, no)				YES	
Hood release control (internal, external)				EXTERNAL	
Vent window control method (crank, friction, pivot).				CRANK	
Windshield (one piece, two piece; curved, flat)				ONE PIECE CURVED	
Rear window type (one piece, two piece, three piece; curved, flat)	ONE PIECE CURVED	ONE PIECE FLAT	ONE PIECE CURVED	ONE PIECE CURVED	
Windshield glass area	1244.5	1244.5	1412.1	1412.1	
Backlight glass area	1099.6	P-922.4	1120.5	498.8	
Total glass area	3669	3535.7	3949.2	3989.4	

BODY—TYPES AND STYLE NAMES

7533 CENTER PARTION GLASS - 1145.9

Body type, number of passengers, and style names (use letter code shown below followed by passenger capacity and style name e.g., N-6 Ranchwagon)		
	62 SERIES	6239D K-6 SEDAN DE VILLE 6239 K-6 SEDAN 6237 J-6 COUPE 6237D J-6 COUPE DE VILLE 6237S J-6 SPE. COUPT (SEVILLE) 6267 L-5 CONV. BIARRITZ 6267S L-5 SPE. CONV.
	60 SERIES	6039 K-6
	75 SERIES	7523 H-8 SEDAN 7533 H-8 IMP. SEDAN

Body type code

- | | |
|--|---|
| A—Coupe—2 door flatback
B—Coupe—2 door notchback
C—Sedan—2 door flatback
D—Sedan—2 door notchback
E—Sedan—4 door flatback (4 windows)
F—Sedan—4 door flatback (6 windows)
G—Sedan—4 door notchback (4 windows)
H—Sedan—4 door notchback (6 windows)
J—Hardtop—2 door
K—Hardtop—4 door | L—Convertible—2 door
M—Convertible—4 door
N—Station wagon—2 door
P—Station wagon—4 door
Q—Combined passenger and utility—2 door
R—Combined passenger and utility—4 door
S—Sedan delivery
T—Limousine |
|--|---|

INDEX

SUBJECT	PAGE	SUBJECT	PAGE
Battery.....	8	Kingpin.....	18
Belts, drive.....	7	Lamp bulbs.....	11
Body		Linings—clutch, brake.....	12, 16
General Body Information.....	19, 23	Lubrication.....	5, 6, 13, 14, 15
Height dimensions.....	20	Muffler.....	6
Length dimensions.....	21	Overdrive.....	13
Overall dimensions.....	1	Piston pins.....	3
Trunk opening dimensions.....	19	Pistons.....	2
Width dimensions.....	22	Propeller shaft.....	14
Types.....	23	Radiator, radiator hoses.....	7
Brakes		Rear axle.....	1, 15
Parking.....	16	Rims.....	15
Service.....	15, 16	Rings.....	3
Camber.....	18	Shock absorbers	
Camshaft.....	4	Front.....	17
Capacities		Rear.....	18
Cooling system.....	7	Spark plugs.....	9
Fuel tank.....	6	Springs	
Lubricants		Front.....	17
Crankcase.....	6	Rear.....	18
Overdrive.....	13	Valve.....	5
Transmissions.....	13, 14	Stabilizer	
Rear axle.....	15	Front.....	17
Carburetor.....	6	Rear.....	18
Caster.....	18	Starting motor.....	8
Choke, automatic.....	6	Steering.....	1, 17, 18
Circuit breakers.....	11	Suppression.....	9
Clutch (pedal operated).....	12	Suspension:	
Coil, ignition.....	9	Front.....	16, 17
Connecting rods.....	3	Rear.....	18
Cooling system.....	7	Switches.....	10
Crankshaft.....	3, 4	Tailpipe.....	6
Cylinders, cylinder head.....	2	Timing, engine.....	4, 5, 9
Distributor.....	9	Tires.....	1, 15
Electrical System.....	8, 9, 10, 11	Toe-in.....	18
Engine		Torque converter.....	14
Bore and stroke, displacement.....	1, 2	Torque, maximum.....	1, 2
Compression ratio.....	1, 2	Transmission	
Firing order, cylinder numbering.....	2, 9	Automatic.....	13, 14
General information.....	1, 2	Conventional.....	12, 13
Lubrication.....	5, 6	Conventional with overdrive.....	13
Type.....	1, 2	Ratios.....	12
Exhaust system.....	6	Types.....	1, 12, 13
Fan.....	7	Tread.....	1, 22
Frame.....	16	Turning diameter.....	1, 17
Fuel.....	6	Universal joints.....	14
Fuel pump.....	6	Valves, intake and exhaust.....	4, 5
Fuel system.....	6	Voltage regulator.....	8
Fuses.....	11	Water pump.....	7
Generator.....	8	Weight, shipping.....	1
Horns.....	10	Wheel alignment.....	18
Horsepower		Wheelbase.....	1, 21
Maximum brake.....	1, 2	Wheels.....	15
Taxable.....	2	Wheel spindle.....	18
Ignition system.....	9	Windshield wiper.....	10
Instruments.....	10		

BODY STYLE

STYLE NO.	SERIES	BODY TYPE	WHEEL BASE	OVERALL LENGTH
57-7059X	57-70	5 Pass. Sedan	126	216.3

1957 SERIES BODY NAME PLATE

It is very important that the information on the Body Name Plate for 1957 Series cars be checked to determine accessories, paint colors, trim and other features in the body construction.

The plate is attached to the hood ledge of the body under the engine hood. The following information noted with numerical or letter key symbols will be found on the body plate.

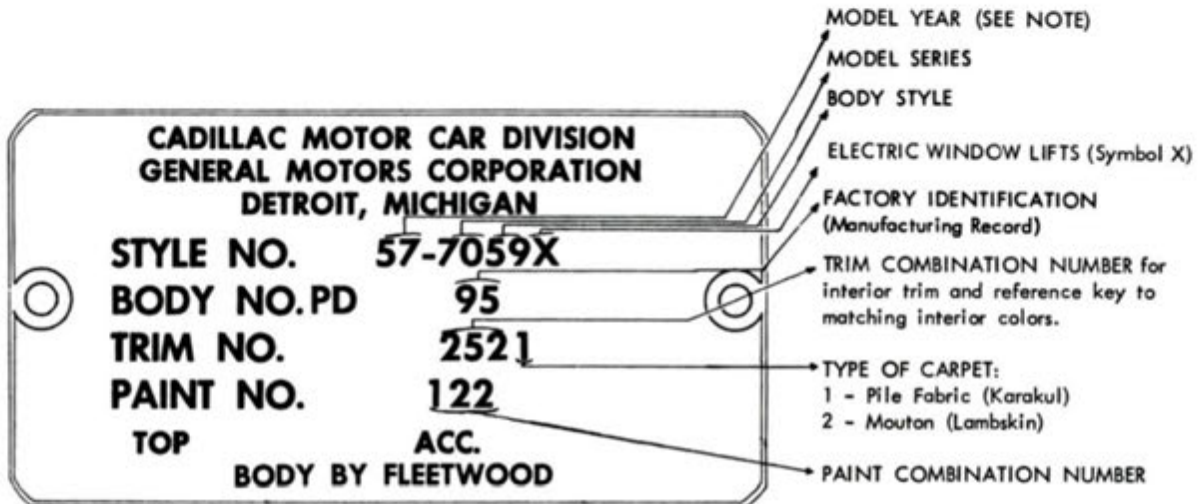

NOTE: Beginning with series 57-70 after body number 260 the body name plate no longer indicates the model year with the style number. Thus the style No. for both 57-7059X and 58-7059X is shown only as "7059X". To distinguish between models 57-7059X and 58-7059X when ordering replacement parts refer to engine serial number. Engine serial numbers on 57-70 series being with 5770; on 58-70 series they begin with 58P.

CHART OF CAPACITIES

Series 57-70

Engine Crankcase	5 qts.	Rear Axle	5 pts.
Cooling System (with Heater)	22 1/2 qts.	Power Steering, Complete System	1 5/8 pts.
Gasoline Tank	20 gal.	Air Conditioner - Freon #12	4 lbs.
Hydramatic Transmission Refill	11 qts.	Compressor Oil	9 oz.
Dry	11 1/2 qts.		

BATTERY SPECIFICATIONS

Series	Delco Catalog No.		No. of Volts	20 Hour Rating in Amp. Hours	Separators	Capacity Ratings		Length	Width	Height
	Wet Type	Dry Type				No. of Min. 150 Amp. @ 0°F	5 Second Voltages 150 Amp. @ 0°F			
57-70	670	671	12	72	Rubber	6.0	9.6	12 1/32"	6 13/16"	8 7/8"

**COLOR COMBINATIONS
SERIES 57-70
EXTERIOR COLORS**

BODY AND SHEET METAL

(x) Comb. Color Code No.	Color Name	(Stock No.) Matching Colors (Dupont)	(Stock No.) Matching Colors R & M
110	Ebony		A946
112	Chamonix White	2596-L	A932
116	Wimbledon Gray	2597-L	A933
118	Deauville Gray		A934
122	Lake Placid Blue		A935
124	Copenhagen Blue		A936
126	Fairfax Blue		A937
132	Jamaican Green	2598-L	A938
134	Laurentian Green		A939
136	Plantation Green		A940
140	Manila	2599-L	A941
144	Sandalwood		A942
148	Kenya Beige	2600-L	A943
149	Nairobi Pearl	2601-L	A944
152	Maharani Maroon		A945

NOTE: (x) Color Code Combination will be found stamped on Body Plate on Dash.
All Exterior Colors are Acrylic Lacquers.

**COLOR COMBINATIONS-INTERIOR
SERIES 57-70**

**GENERAL INSTRUCTIONS FOR DETERMINING INTERIOR LACQUER COLORS.
IF COLOR SHADE IS NOT KNOWN IT WILL BE NECESSARY TO REFER TO
DETAILED CHARTS THAT FOLLOW.**

To take care of refinishing or touch up on interiors of Series 57-70 Style 57-7059X, it is possible to determine the matching colors from the detailed paint charts, as follows:

1. First determine interior trim combination number from Body Identification Plate on dash under engine hood. With this reference number, application can be made to the matching trim code number in the paint charts for parts indicated by group number.
2. The paint application to the most frequently referred to parts will not require reference to the trim code as they can be readily identified by their basic colors Gray, White, Blue, Beige, Black and Green. The Paint Chart for this usage covers the following groups:

Group No.

- 7.3880 Horn Ring
- 18.0100 Steering Column Jacket and Cover
- 18.0175 Cover, Steering Column
- 33.0020 Instrument Panel
- 33.0260 Instrument Panel Ash Tray Door
- 33.1060 Instrument Panel Door
- 34.5550 Trim Panel Side of Cowl
- 34.8015 Trim Panel Front Door Upper
- 34.8045 Trim Panel Rear Door Upper
- 34.8745 Trim Panel Rear Quarter Upper

NOTE: The interior colors are not compatible with exterior Acrylic type Lacquers.

COLOR CHARTS FOR INTERIOR PAINTED MOLDINGS, PANELS AND RELATED PARTS

Interior moldings, panels and painted parts are finished in colors to harmonize with the interior trim material color shades. To assist in determining trim color requirements, if the trim color is not known, reference can be made to the trim code chart shown below. For convenience and assistance in procurement, the original color name and numbers are shown with matching Dupont formula number reference. On parts using high temperature drying enamels, a reference is made to nearest match of air-drying lacquers.

For easy reference and to cover the most commonly called for areas and parts, the reference is keyed to three (3) major group charts, Instrument Panel, Door and Quarter Trim Panels, Steering Column Jacket and Covers, Horn Ring and other parts.

TRIM CODE COLOR REFERENCE CHART

REFERENCE CHART FOR DETERMINING PAINT COLORS ON INTERIOR PARTS FROM THE PAINT CHARTS BY TRIM CODE NO.

NOTE: TRIM CODE NUMBERS SHOWN IN THIS PARTS LIST CORRESPOND TO THE FIRST THREE DIGITS OF THE TRIM CODE NO. STAMPED ON METAL NAME PLATE ATTACHED TO LEFT SIDE OF COWL UNDER HOOD. (SEE NAME PLATE EXAMPLE ON PAGE G-3).

<u>TO MATCH</u> <u>TRIM</u> <u>CODE NO.</u>	<u>TRIM COLOR</u>
110,120,130,140,150	Lt. Gray (Cloth) w/Dark Gray (Leather)
111,121,131,141	Lt. Gray (Cloth) w/Lt. Gray (Leather)
118,128,138,148	Lt. Gray (Cloth) w/White (Leather)
151	Lt. Gray (Leather)
158	Lt. Gray (Leather) w/White (Leather)
212,222,232,242	Med. Blue (Cloth) w/Med. Blue (Leather)
218,228,238,248	Med. Blue (Cloth) w/White (Leather)
252	Med. Blue (Leather)
258	Med. Blue (Leather) w/White (Leather)
414,424,434,444	Beige (Cloth) w/Beige (Leather)
454	Beige (Leather)
616,626,636,646	Med. Green (Cloth) w/Green (Leather)
618,628,638,648	Med. Green (Cloth) w/White (Leather)
656	Med. Green (Leather)
658	Med. Green (Leather) w/White (Leather)
858	White (Leather)
859	White (Leather) w/Black (Leather)
958	Black (Leather) w/White (Leather)
959	Black (Leather)

SERIES 57-70

COLOR CHARTS FOR INTERIOR PAINTED MOLDINGS, PANELS AND RELATED PARTS

GROUP 7.3880 HORN RING	GROUP 33.1060 INSTRUMENT PANEL DOOR
GROUP 18.0100 STEERING COLUMN JACKET & COVER	GROUP 34.5550 TRIM PANEL SIDE OF COWL
GROUP 18.0175 COVER, STEERING COLUMN	GROUP 34.8015 TRIM PANEL FRONT DOOR (UPPER)
GROUP 33.0020 INSTRUMENT PANEL	GROUP 34.8045 TRIM PANEL REAR DOOR (UPPER)
GROUP 33.0260 INSTRUMENT PANEL ASH TRAY DOOR	GROUP 34.8745 TRIM PANEL REAR QUARTER (UPPER)

<u>TO MATCH TRIM CODE NO.</u>	<u>MOLDING AND PANEL COLORS</u>	<u>R - M LACQUER</u>	<u>DUPONT FORMULA NO.</u>
Style 57-7059X			
110,111,120,121,130, 131,140,141,150,151	Wimbledon Gray	L-21-A-048	82834
118,128,138,148,158, 218,228,238,248,258, 618,628,638,648,658, 858,859,958,959	Chamonix White	L-21-W-038	82838
212,222,232,242,252	Lake Placid Blue	L-21-B-103	82835
414,424,434,444,454	Kenya Beige	L-21-N-047	82837
616,626,636,646,656	Jamaican Green	L-21-G-097	82836

**GROUP 34.0320 FRONT SEAT ADJUSTERS
GROUP 35.0000 BATTERY BOX AND COVER
GROUP 54.6375 AIR CONDITIONING DOORS**

<u>TO MATCH TRIM CODE NO.</u>	<u>COLOR NAME</u>	<u>R - M LACQUER</u>	<u>DUPONT FORMULA NO.</u>
110,111,118,120,121, 128,130,131,138,140, 141,148,150,151,158	Deauville Gray	L-21-A-049	
212,218,222,228,232, 238,242,248,252,258	Copenhagen Blue	L-21-B-104	
414,424,434,444,454	Nairobi Brown	L-21-N-048	
616,618,626,628,636 638,646,648,656,658	Laurentian Green	L-21-G-098	
858,859,958,959	Black	L-21-K-400	44

GROUP 54.0210 FRONT RADIO SPEAKER HOUSING

<u>TO MATCH TRIM CODE NO.</u>	<u>COLOR NAME</u>	<u>R - M LACQUER</u>	<u>DUPONT FORMULA NO.</u>
110,111,120,121,130, 131,140,141,150,151	Wimbledon Gray	L-21-A-048	82834
118,128,138,148,158	Deauville Gray	L-21-A-049	
212,222,232,242,252	Lake Placid Blue	L-21-B-103	82835
218,228,238,248,258	Copenhagen Blue	L-21-B-104	
414,424,434,444,454	Kenya Beige	L-21-N-047	82837
616,626,636,646,656	Jamaican Green	L-21-G-097	82836
618,628,638,648,658	Laurentian Green	L-21-G-098	
858,859,958,959	Black	L-21-K-400	44

Color Options

Code	Name	Color No.
110	Ebony	L 41 K 001
112	Chamonix White	885 90731
116	Wimbledon Gray -Metallic	887 90732
118	Deauville Gray -Metallic	L 42 A 010
122	Lake Placid Blue -Metallic	L 42 B 006
124	Copenhagen Blue -Metallic	L 42 B 007
126	Fairfax Blue -Metallic	L 42 B 009
132	Jamaican Green -Metallic	887 90737
134	Laurentian Green -Metallic	L 42 G 008
136	Plantation Green -Metallic	L 42 G 010
140	Manila	885 90740
144	Sandalwood	L 41 N 005
148	Kenya Beige -Metallic	887 90742
149	Nairobi Pearl -Metallic	887 90743
152	Maharani Maroon -Metallic	L 42 M 005

All Colors Are in "Acrylic Brougham" Finish.

In addition to the above exclusive Brougham colors, the 24 regular and Eldorado (Biarritz - Seville) options are available.

Two-tone color combinations are not feasible, as the roof is brushed stainless steel.

ELDORADO BROUGHAM—UPHOLSTERY OPTIONS

7059

CODE-P

C O D E	Basic Sections of Seat Cushions, Back Rests and Front Seat Center Arm Rest.	End Section of Seats, Center Arm Rest in Rear Back Rest, Center Section of Rear Seat Cushion and Tops of Door Arm Rests.
	Cloth	Leather
	Combined With	
110	Gray Mojave	Dark Gray
111	Gray Mojave	Light Gray
118	Gray Mojave	White
120	Gray Parisienne	Dark Gray
121	Gray Parisienne	Light Gray
128	Gray Parisienne	White
130	Gray Bayou	Dark Gray
131	Gray Bayou	Light Gray
138	Gray Bayou	White
140	Gray Cashmere Broadcloth	Dark Gray
141	Gray Cashmere Broadcloth	Light Gray
148	Gray Cashmere Broadcloth	White
212	Blue Mojave	Blue
218	Blue Mojave	White
222	Blue Parisienne	Blue
228	Blue Parisienne	White
232	Blue Bayou	Blue
238	Blue Bayou	White
242	Blue Cashmere Broadcloth	Blue
248	Blue Cashmere Broadcloth	White
414	Beige Mojave	Beige
424	Beige Parisienne	Beige
434	Beige Bayou	Beige
444	Beige Cashmere Broadcloth	Beige
616	Green Mojave	Green
618	Green Mojave	White
626	Green Parisienne	Green
628	Green Parisienne	White
636	Green Bayou	Green
638	Green Bayou	White
646	Green Cashmere Broadcloth	Green
648	Green Cashmere Broadcloth	White

ALL LEATHER		
151	Light Gray Entirely	
150	Light Gray	Dark Gray
158	Light Gray	White
252	Blue Entirely	
258	Blue	White
454	Beige Entirely	
656	Green Entirely	
658	Green	White
858	White Entirely	
859	White	Black
959	Black Entirely	
958	Black	White

Carpets - Nylon Karakul, Code No. 1 or Mouton, Code No. 2

To order carpet, add No. 1 or 2 to three digit upholstery code number.
i.e. 2522 is Blue Leather Entirely and Mouton Carpet.