

# AUTOMOBILE MANUFACTURERS ASSOCIATION CONSOLIDATED SPECIFICATION QUESTIONNAIRE

<b>MAKE OF CAR:</b> CADILLAC	<b>MODEL NAME</b>	<b>SYMBOL</b>
<b>COMPANY:</b> CADILLAC MOTOR CAR DIVISION GENERAL MOTORS CORPORATION 2860 CLARK AVENUE DETROIT 32, MICHIGAN	SEDAN	6219
	COUPE	6237
	COUPE DEVILLE	6237D
	COUPE CONV.	6267
	ELDORADO	6267S
	SEDAN	6019
<b>MODEL YEAR:</b> 1954	<b>DATE</b> 12-20-53	SEDAN
		SEDAN IMP.
		7533

REVISED 3-1-54

## TABLE OF CONTENTS

General Specifications.....	1	Frame.....	16
Engine.....	2	Front Suspension.....	16
Electrical.....	8	Steering.....	17
Drive Units.....	12	Rear Suspension.....	18
Brakes.....	15	Body.....	19
Index.....	24		

- NOTES:**
1. The specifications set forth herein are those in effect at the date of compilation and are subject to change without notice.
  2. All specifications are standard for the models under which they are listed unless otherwise indicated.
  3. All dimensions are nominal engineering dimensions unless otherwise indicated.
  4. Unless otherwise indicated, specifications apply to 5 or 6 passenger, 4-door sedan or equivalent.

## GENERAL SPECIFICATIONS

Model	6219	6237	6237D	6267 & 6267S	6019	75
Wheelbase	129				133	149.8
Tread	60					
	63.1					
Maximum Overall Dimensions	216.4		223.4		227.4	237.1
	80					
	62.1		59.7		60.1	62.1
Steering ratio—overall	x			21.3:1		
Turning diameter (curb to curb)	45				46.3	52.7
Shipping weight*	4330	4347	4409	4598 4809	4490	5031 5093
Transmission— (Specify standard, optional, not avail.)	Conventional			NA		
	Overdrive			NA		
	Automatic			STANDARD		
Axle ratio	Conventional			NA		
	Overdrive			NA		
	Automatic			3.07:1 **		
Tire size	8.00 x 15 - 4 PLY RATING - BLACK ***					3.77:i
Engine	Type			90° - V		
	No. of cylinders			8		
	Valve arrangement			OVERHEAD		
	Bore and stroke			3.8125 x 3.625		
	Piston displacement, cu. in.			331		
	Standard compression ratio			8.25:1		
	Maximum bhp at engine rpm			230 @ 4400		
Maximum torque at rpm			330 @ 2700			

\*Standard car weight, not including gas and water. \*\* 3.36 OPT.

\*\*\* 62-60 SERIES = 8.20 x 15 WHITE WALLS OPTIONAL. STD. ON 6267 S.

x - REVISED

# AMA Consolidated Specification Questionnaire

**MAKE OF CAR** CADILLAC **MODEL YEAR** 1954

**MODEL** ALL

## ENGINE—GENERAL

Type	V, In-line, other	V	
	Angle of V	90°	
No. of cylinders		8	
Valve arrangement		OVERHEAD	
Bore and stroke		3.8125 x 3.625	
Piston displacement, cu. in.		331	
Numbering system (front to rear)	L. Bank	1-3-5-7	
	R. Bank	2-4-6-8	
Firing order		1-8-4-3-6-5-7-2	
*Compression ratio	Standard Head	8.25:1	
	Optional Head	NONE	
Cylinders	Head	CAST IRON	
	Material	NONE	
	Sleeve—Wet, dry, other, none	NONE	
Number of mounting points	Front	TWO	
	Rear	ONE	
Taxable horsepower	(Dia. <sup>2</sup> x No. Cyl.) 2.5	46.5	
Advertised max. brake horsepower at engine RPM*	Standard head	230 @ 4400	
	Optional head	NONE	
	With fuel (Octane and method)	Standard Head	93 RESEARCH
		Optional Head	NONE
Max. torque (lb. ft. @ RPM)	Standard head	330 @ 2700	
	Optional head	NONE	
Recommended idle speed (neutral)		400 RPM (DRIVE RANGE)	

## ENGINE—PISTONS

Material	ALUMINUM ALLOY		
Description and finish	T SLOT - CAM GROUND - STANNATE COATED		
Weight (piston only) oz.	19.680		
Clearance	Top land	.0265 - .0295	
	Skirt	Top	.0009
		Bottom	-.0007
Ring groove depth	No. 1 ring	.187	
	No. 2 ring	.187	
	No. 3 ring	.190	
	No. 4 ring	NONE	

\*Corrected as defined by SAE Engine Test Code, with the following standard power consuming accessories: GENERATOR, WATER PUMP, MANIFOLD, FUEL PUMP, MANUAL SPARK ADVANCE, AND MANIFOLD HEAT OFF.

\* EXPORT 7.1:1

# AMA Consolidated Specification Questionnaire

**MAKE OF CAR** CADILLAC **MODEL YEAR** 1954

**MODEL** ALL

## ENGINE—RINGS

<b>Type (top to bottom)</b>	No. 1 oil or comp.	COMP.
	No. 2 oil or comp.	COMP.
	No. 3 oil or comp.	OIL
	No. 4 oil or comp.	NONE
<b>No. rings above piston pin</b>		3
<b>Compression</b>	<b>Material</b>	STEEL NO. 1 CAST IRON No. 2
	<b>Coating</b>	CHROME PLATED NO. 1 LUBRITED NO. 2
	<b>Width</b>	.0781
	<b>Gap</b>	.010 - .020
	<b>Maximum wall thickness</b>	.165 STEEL .184 CAST IRON
<b>Oil</b>	<b>Material</b>	CAST IRON
	<b>Coating</b>	LUBRITE
	<b>Width</b>	.1875
	<b>Gap</b>	.010 - .020
	<b>Maximum wall thickness</b>	.150
<b>Location of expanders</b>		NONE

## ENGINE—PISTON PINS

<b>Material</b>		1045 STEEL	
<b>Length</b>		3.093	
<b>Diameter</b>		1.00"	
<b>Type</b>	Locked in rod, in piston, floating, etc.	LOCKED IN ROD	
	<b>Bushing</b>	In rod or piston	NONE
		<b>Material</b>	NONE
<b>Clearance</b>	In piston	.00005 - .0001"	
	In rod	0	
<b>Direction offset in piston</b>		1/16 TOWARD MAX. THRUST SIDE	

## ENGINE—CONNECTING RODS

<b>Material</b>		1041 STEEL
<b>Weight (oz.)</b>		23.49
<b>Length (center to center)</b>		6.625
<b>Bearing</b>	<b>Material</b>	MORAINÉ 400 (MORAINÉ DUREX OPTIONAL)
	<b>Type (cast-in or removable)</b>	REMOVABLE
	<b>Effective length</b>	.8909 - .9009
	<b>Clearance</b>	.0005 - .0020
	<b>End play</b>	.008 - .014 (TOTAL TWO RODS)

## ENGINE—CRANKSHAFT

<b>Material</b>		1145 STEEL
<b>Weight (lb.)</b>		61.5

# AMA Consolidated Specification Questionnaire

MAKE OF CAR CADILLAC MODEL YEAR 1954  
ALL

**MODEL** \_\_\_\_\_

**ENGINE—CRANKSHAFT (cont.)**

Vibration damper type		RUBBER ABSORPTION	
End thrust taken by bearing (No.)		REAR MAIN	
Crankshaft end play		.001 - .005	
Main bearing	Material	MORAINE DUREX	
	Type (cast-in or removable)	REMOVABLE	
	Clearance	.0008 - .0025	
	Journal dia. and bearing effective length	No. 1	2.5 x .907
		No. 2	"
		No. 3	"
		No. 4	"
		No. 5	2.5 x 1.622
No. 6		NONE	
No. 7		NONE	
Direction offset from cyl. bore		NONE - SEE PISTON	
Connecting rod crankpin journal diameter		2.25	

**ENGINE—CAMSHAFT**

Material		GM 120 M CAST IRON	
Bearings	Material	STEEL BACKED BABBITT	
	Number	5	
Gear or chain		CHAIN	
Crankshaft gear or sprocket material		1118 OR 1115 STEEL	
Type of drive	Camshaft gear or sprocket material		1115 STEEL
	Timing chain	Make	LINK BELT
		No. of links	46
		Width	.6875
		Pitch	.500

**ENGINE—VALVE SYSTEM**

Hydraulic lifters (yes, no)		YES
Special provision for valve rotation (intake, exhaust)		NO
Rocker ratio		1.5:1
Operating tappet clearance (indicate hot or cold)	Intake	AUTOMATIC
	Exhaust	"
Tappet clearance for timing	Intake	--
	Exhaust	--
Timing marks on fly-wheel, damper, other		VIBRATION DAMPER

# AMA Consolidated Specification Questionnaire

**MAKE OF CAR** CADILLAC **MODEL YEAR** 1954

**MODEL** ALL

## ENGINE—VALVE SYSTEM (cont.)

<b>Timing</b>	Intake	Opens (°BTC)	WITHOUT RAMP	22°	
		Closes (°ABC)	" "	67	
	Exhaust	Opens (°BBC)	" "	63	
		Closes (°ATC)	" "	27	
<b>Intake</b>	Material		3140 STEEL (RICH) (EATON) 8645		
	Overall length		4.628 - 4.648 4.628 - 4.653		
	Actual overall head dia.		1.750		
	Angle of seat		44°		
	Seat insert material		NONE		
	Stem diameter		.3415 - .3425		
	Stem to guide clearance		.0005 - .0025		
	Lift		.365		
	Outer spring press. and length	Valve closed (lb. @ in.)	61 - 1.696"		
		Valve open (lb. @ in.)	140 - 1.326		
	Inner spring press. and length	Valve closed (lb. @ in.)	NONE		
		Valve open (lb. @ in.)	--		
	<b>Exhaust</b>	Material		81940 (EATON) AND (RICH) HEAD-N82120 STEM - 8729	
		Overall length		4 21/32	
Actual overall head dia.		1.562			
Angle of seat		44°			
Seat insert material		NONE			
Stem diameter		.3415 - .3420			
Stem to guide clearance		.001 - .0025			
Lift		.365			
Outer spring press. and length		Valve closed (lb. @ in.)	61 - 1.696		
		Valve open (lb. @ in.)	140 - 1.326		
Inner spring press. and length		Valve closed (lb. @ in.)	NONE		
		Valve open (lb. @ in.)	--		

## ENGINE—LUBRICATION SYSTEM

<b>Type of lubrication (splash, pressure, nozzle)</b>	Main bearings	PRESSURE
	Connecting rods	"
	Piston pins	SPLASH
	Camshaft bearings	PRESSURE
	Tappets	"
	Timing gear or chain	METERED CENTRIFUGAL FLOW
	Cylinder walls	INTERMITTENT JET

# AMA Consolidated Specification Questionnaire

MAKE OF CAR CADILLAC MODEL YEAR 1954

MODEL ALL

## ENGINE—LUBRICATION SYSTEM (cont.)

Oil pump type	GEAR
Normal oil pressure (lb. @ rpm)	30-35 @ 30 MPH
Oil pressure gage type (electric or mechanical)	ELECTRIC TELL TALE
Type oil intake (floating, stationary)	FLOATING
Oil filter type (full flow, partial flow)	PARTIAL FLOW
Capacity of crankcase, less filter—refill (qt.)	5
Oil grade recommended (SAE viscosity and temperature range)	+32°F. 20W or SAE 20
	+10°F. 20W
	-10°F. 10W
	BELOW -10°F. 5W
Oil type recommended	FOR SERVICE MS OR DG

## ENGINE—FUEL SYSTEM

Recommended Fuel	Standard head	PREMIUM	
	Optional head	NONE	
Fuel Tank	Capacity (gals.)	20	
	Filler Location	LEFT HAND TAIL LAMP	
Fuel Filter	Type	A.C.	
	Location	RIGHT HAND FRONT OF ENGINE	
Fuel pump	Type (elec. or mech.)	MECHANICAL	
	Location	TOP RIGHT FRONT	
	Pressure range	4 P.S.I. to 5.25 P.S.I. @ 1800 RPM	
	Vacuum booster (std., optl., none)	STD. (ON OIL PUMP)	
Carburetor	Make	CARTER AND ROCHESTER PRODUCTS	
	Model number	W.C.F.B. 2109-S 4-GC	
	Number used	1	
	Type	Downdraft, side inlet, other	DOWN DRAFT - TOP INLET
		Single or dual	4 BARREL
	Intake manifold heat control (manual, auto., none)	AUTOMATIC	
	Automatic choke type (integral, other)	INTEGRAL	
	Air cleaner type	Standard	AC OIL BATH
		Optional	NONE

## ENGINE—EXHAUST SYSTEM

Type (single, single with cross-over, dual, other)	DUAL	
Muffler type (rev. flow, str. thru, sep. resonator)	REVERSE FLOW MUFFLERS AND STRAIGHT THRU RESONATORS	
Exhaust pipe dia.	Branch	--
	Main	2"
Tail pipe diameter	1.75"	

# AMA Consolidated Specification Questionnaire

MAKE OF CAR CADILLAC MODEL YEAR 1954

MODEL 60-62 75

## ENGINE—COOLING SYSTEM

Type (pressure system, atmospheric, other)		PRESSURE	
Radiator cap relief valve press.		12-15 LBS.	
Circulation thermostat	Type (choke, bypass)	CHOKE	
	Starts to open at	163° - 168°	
Water pump	Type (centrifugal, other)	CENTRIFUGAL - DUAL OUTLET	
	Number of pumps	1	
	Drive (V-belt, other)	V-BELT	
	Bearing type	DOUBLE ROW BALL BEARING	
By-pass recirculation type (internal, external)		INTERNAL	
Radiator core type (cellular, tube and fin)		TUBE & CENTER	
Cooling system capacity	With heater (qt.)	22.00	24.50
	Without heater (qt.)	19.75	19.75
Water jackets full length of cylinder (yes, no)		YES	
Water all around cylinder (yes, no)		YES	
Radiator hose	Lower	Number and type (molded, straight)	1 - MOLDED
		Inside diameter and length	1 3/4 x 8 7/16
	Upper	Number and type (molded, straight)	1 - MOLDED
		Inside diameter and length	1 3/4 x 8 7/16
	By-pass	Number and type (molded, straight)	NONE
		Inside diameter and length	NONE
Drive belts	Fan	Number used	1
		Angle of V	40°
		Outside length	57"
		Width	.380
	Generator	Angle of V	SAME AS FAN
		Outside length	" " "
		Width	" " "
Fan	Number of blades and spacing	4 @ 76°	(2 AT) 92° 30'
	Diameter	18	(2 AT) 65°
	Ratio—fan to crankshaft revolutions	.95-1	(1 AT) 45°
	Bearing type	NONE	18 1/2

\*POWER STEERING BELT - 40° V 57" OUTSIDE LENGTH .380 WIDTH

# AMA Consolidated Specification Questionnaire

MAKE OF CAR CADILLAC MODEL YEAR 1954

MODEL ALL

## ELECTRICAL—SUPPLY SYSTEM

<b>Battery</b>	Make and Model		DELCO REMY	
	Voltage Rtg. & Plates/cell		3EM 60W	
	SAE Designation & Amp Hr. Rtg		55 AMP. HR. @ 20 HOURS	
	Location		UNDER HOOD ON TRAY ATTACHED TO RIGHT FRONT DASH TO FRAME BRACKET	
Terminal grounded		NEGATIVE		
<b>Generator</b>	Make		DELCO REMY	
	Model		1102002	
	Type		12 VOLT	
	Ratio—Gen. to Cr/s rev.		2.15:1	
<b>Regulator</b>	Make		DELCO REMY	
	Model		1118750	
	Type		CURRENT & VOLTAGE CONTROL	
	Cutout relay	Closing voltage @ generator rpm	11.8 - 13.6 ADJ. 12.8	
		Reverse current to open	.0 - 4	
	Regulated	Voltage	14.0 - 15.0 ADJ. 14.5	
		Current	27-33° @ OPERATING TEMP. -- ADJ. 30°	
	Min. Gen. rpm required		2150	
Voltage test conditions	Temperature	HOT - RUN GEN. 15 MIN. AT FULL ELECTRIC LOAD BEFORE TESTING.		
	Load	8-10 AMPS VARIABLE RESISTANCE METHOD.		
	Other	1 1/2 OHM FIXED RESISTANCE METHOD.		

## ELECTRICAL—STARTING SYSTEM

<b>Starting motor</b>	Make		DELCO REMY	
	Model		1107622	
	Rotation (drive end view)		CLOCKWISE	
	Engine cranking speed		60 RPM @ 0° F.	
	Test conditions		N.A.	
	Lock test	Amps	460 AMPS. MAX.	
		Volts	5.2 VOLTS MAX.	
		Torque (lb. ft.)	11.5 FT. LBS. MIN.	
No load test	Amps	75 AMPS. MAX.		
	Volts	10.3		
	RPM (min.)	6500		
<b>Motor control</b>	Switch (solenoid, manual)		SOLENOID	
	Starting procedure		<p>COLD START - DEPRESS ACCELERATOR ALL THE WAY AND REMOVE FOOT - TURN IGNITION KEY TO FULL RIGHT POSITION TO START.</p> <p>WARM START - DEPRESS ACCELERATOR PEDAL HALFWAY - HOLD UNTIL ENGINE STARTS.</p>	



# AMA Consolidated Specification Questionnaire

**MAKE OF CAR** CADILLAC **MODEL YEAR** 1954  
 REVISED 3-1-54

**MODEL** ALL

## ELECTRICAL—STARTING SYSTEM (cont.)

<b>Motor drive</b>	Engagement type	x	SPIRAL SPLINE & OVER-RUNNING CLUTCH	
	Pinion meshes (front, rear)		FRONT	
	Number of teeth	Pinion		9
		Flywheel		176
	Flywheel tooth face width			.500

## ELECTRICAL—IGNITION SYSTEM

<b>Coil</b>	Make	DELCO REMY		
	Model	1115082, RESISTOR #1927809		
	Amps	Engine stopped	3.0	
		Engine idling	1.25	
<b>Distributor</b>	Make	DELCO REMY		
	Model	1110844		
	Spark advance data (at distributor shaft)	Centr. advance start (rpm)	400 - 500	
		Centr. advance max. deg. @ rpm	11.25 - 13.25 @ 2000	
		Vacuum advance start (in. Hg.)	6.5 - 9.0" Hg	
		Vac. adv. (max. deg. @ in. Hg.)	13° - 14.5° @ 16" - 17" Hg	
	Breaker gap (in.)	.016 - .021 ORIGINAL - .016 SERVICE		
	Cam angle (deg.)	31° + 1 1/2°		
	Breaker arm tension (oz.)	19 - 23 oz.		
	C/S deg. @ rpm	x	2 1/2° BTC	
<b>Timing</b>	Mark location	CRANKSHAFT BALANCER		
	Cylinder numbering system (see page 2)	L. 1-3-5-7		R. 2-4-6-8
	Firing order (see page 2)	1-8-4-3-6-5-7-2		
	Make and model	A.C. 46-5		
<b>Spark plug</b>	Thread (mm)	14		
	Tightening torque (lb. ft.)	20-25		
	Gap	.035		
	Conductor type	7 MM		
<b>Cable</b>	Insulation type	NEOPRENE JACKET		
	Spark plug protector	NEOPRENE JACKET		

## ELECTRICAL—SUPPRESSION

<b>Description</b>	
DIST. ROTOR	10,000 OHM RESISTOR
GEN. CONDENSER	.3 MFD CONDENSER ON GENERATOR (ARM TERM.)
COIL CONDENSER	.3 MFD CONDENSER ON COIL (FEED TERM. )
REG. CONDENSER	.5 MFD CONDENSER ON BATTERY TERM. OF REG.

2 ENGINE GROUND STRAPS -- FROM BACK OF EACH HEAD TO DASH.  
 x - REVISED

# AMA Consolidated Specification Questionnaire

**MAKE OF CAR** CADILLAC **MODEL YEAR** 1953

**MODEL** ALL

## ELECTRICAL—INSTRUMENTS AND SWITCHES

<b>Speed-ometer</b>	<table border="1" style="width: 100%; border-collapse: collapse;"> <tr> <td style="width: 50%;"><b>Make</b></td> <td>A. C.</td> </tr> <tr> <td><b>Trip odometer (yes, no)</b></td> <td>YES</td> </tr> </table>	<b>Make</b>	A. C.	<b>Trip odometer (yes, no)</b>	YES	
<b>Make</b>	A. C.					
<b>Trip odometer (yes, no)</b>	YES					
<b>Charge indicator—type</b>		TELL TALE LIGHT				
<b>Temperature indicator—type</b>		ELECTRIC INDICATOR				
<b>Oil pressure indicator—type</b>		TELL TALE LIGHT				
<b>Fuel indicator—type</b>		ELECTRIC INDICATOR				
<b>Ignition switch</b>	<b>Identify positions in order and circuits controlled</b>	CENTER OFF CLOCKWISE 1ST POSITION - ALL CIRCUITS ON 2ND POSITION - IGN. & STARTER CIRCUITS ON COUNTERCLOCKWISE 1ST POSITION - ALL ACCESSORIES ONLY				
	<b>Provision for illumination</b>	YES				
	<b>Location</b>	ON CONTROL PLATE RIGHT OF STEERING COLUMN				
	<b>Theft protection type</b>	NO				
<b>Main lighting switch</b>	<b>Identify positions and lights controlled</b>	PULL OUT - 1ST POSITION - PARKING OR FOG, INSTRUMENT, TAIL. 2ND POSITION - FULL OUT -- INSTRUMENT, HEAD & TAIL LIGHT. RHEOSTAT - CLOCKWISE TO DECREASE INTENSITY OF INSTRUMENT LIGHTS.				
	<b>Locations and lamps controlled</b>	FOG LIGHT SWITCH MOUNTED TO MAIN LIGHT SWITCH CONTROLLED BY SECONDARY RING KNOB. SELECTS PARKING OR FOG LAMPS WHEN HEAD LIGHT SWITCH IS IN 1ST POSITION. FRONT DOOR SWITCH - MAP & COURTESY LIGHTS ON PANEL. REAR DOOR SWITCH - DOME - SEDANS ONLY. REAR DOOR PILLARS - 75 SERIES - DOME & COURTESY. LEFT CENTER PILLAR - SEDANS ONLY. REAR LEFT QUARTER PANEL - CONV. - BOW DOME LAMP.				
<b>Other light switches</b>	<b>Locations and devices controlled</b>	SIDE DOME - SWITCH - COUPE DEVILLE - LEFT QUARTER ARM REST. GLOVE BOX LIGHT SWITCH - UPPER LEFT HAND CORNER OF DOOR. BRAKE LIGHT SWITCH - LOCATED ON BRAKE LEVER - LT. IN INST. PANEL. TURN SIGNAL - SWITCH - IN STEERING COLUMN. HEATER SWITCHES - INST. PANEL RADIO - SWITCH - INTEGRAL PART OF VOLUME CONTROL IN RADIO.				
<b>Windshield wiper</b>	<b>Make</b>	TRICO				
	<b>Type</b>	VACUUM				
	<b>Vacuum booster provision</b>	YES				
	<b>Washer provision</b>	YES				
<b>Horn</b>	<b>Type</b>	VIBRATOR				
	<b>Number used *</b>	TWO				
	<b>Amp draw (each)</b>	LOW 8.5 - 10.5 HIGH 7.5 - 9.5				

\* THREE ON 62675 ONLY

# AMA Consolidated Specification Questionnaire

**MAKE OF CAR** CADILLAC **MODEL YEAR** 1954

**MODEL** ALL

## ELECTRICAL—LAMP BULBS

Give quantity used and trade number, e.g., Headlamp 2-4030.  
Indicate accessories which are not standard equipment by an asterisk following the numbers.

Headlamp	2	SEALED BEAM UNIT	
Headlamp beam indicator	1	57	
Parking light & SIGNAL	2	1034 32-4 C.P.	FOG 2 1026 PARKING 2 67
Tail light	2	1034 32-4 C.P.	
Stop light	2	1034 32-4 C.P.	
Direction indicator	Front	SEE UNDER PARKING LIGHT	
	Rear	SEE UNDER TAIL LAMPS	
	Tell-Tale	2	57
License plate light	2	67	
Instrument light	4	57	
Ignition lock light & CIGARETTE	1	53	
Map light	1	90	
Dome light	1	1004 CHAUFFEURS COMPT. 75 IMP.	- 1 - 90
Clock light	2	57	
Radio dial light	1	57	
Glove compartment light	1	57	
Courtesy light	2	90 75 SERIES	
Trunk compartment light	1	89	
Other OIL TELL TALE	1	57 -- HYD. SHIFT IND.	1 - 57
GEN. TELL TALE	1	57 -- BACK UP LIGHT	2 - 1073 32 C.P.
HAND BRAKE TELL TALE	1	57 -- SEALED BEAM SPOTLIGHT	
BOW DOME LAMP	1	90 CONV. ONLY	
CORNER LAMP	2	90 75 SERIES	

## ELECTRICAL—FUSE & CIRCUIT BREAKER DATA

Use trade number of fuse, e.g., SPB-10. Indicate circuit breaker by ampere capacity suffixed by letters "C.B.", e.g., 30 C.B. Where fuse or circuit breaker protects multiple circuits indicate first use by a letter and repeat the same letter for all units protected by the same fuse or circuit breaker, e.g., Parking light: SPB-10 (a), Direction indicator: same as (a).

Headlamp	22A C.B. - LIGHT SWITCH
Headlamp beam indicator	"
Parking light	"
Tail light	"
Stop light	"
Direction indicator	6A FUSE - ON DASH INSIDE CAR
License plate light	22 A.C.B.
Instrument light	"
Ignition light	"
Map light	"
Dome light	"
Clock	"
Clock light	"
Radio	7.5 A
Glove compartment light	22 A.C.B.
Courtesy light	"
Trunk compartment light	"
Other	BACK UP - 9A
HEATER	20A
BODY FEED	22 A.C.B.
FOG LIGHT	"
SPOT LIGHT	9A

HYDRAULIC WINDOW CONTROLS CB-15

# AMA Consolidated Specification Questionnaire

**MAKE OF CAR** CADILLAC **MODEL YEAR** 1954

**MODEL** ALL

## DRIVE UNITS—CLUTCH (PEDAL OPERATED)

<b>Make</b>		N. A.	
<b>Type (dry or wet plate)</b>			
<b>In combination with fluid coupling (yes, no)</b>			
<b>Semi-centrifugal (yes, no)</b>			
<b>Type pressure plate springs</b>			
<b>Total plate pressure (lb.)</b>			
<b>No. of clutch driven discs</b>			
<b>Clutch facing</b>	<b>Material</b>		
	<b>Inside diameter</b>		
	<b>Outside diameter</b>		
	<b>Total eff. area (sq. in.)</b>		
	<b>Thickness</b>		
	<b>Number required</b>		
	<b>Engagement cushioning method</b>		
	<b>Release bearing</b>	<b>Type</b>	
		<b>Method of lubrication</b>	
	<b>Torsional damping</b>	<b>Method (springs, other)</b>	
<b>Frict. mat.</b>			

## DRIVE UNITS—TRANSMISSIONS

<b>Conventional (std. or opt.)</b>	N. A.
<b>Conventional with overdrive (std. or opt.)</b>	N. A.
<b>Automatic (std. or opt.)</b>	STD.

## DRIVE UNITS—CONVENTIONAL TRANSMISSION

N. A.

<b>Number of forward speeds</b>		
<b>Transmission ratios</b>	<b>In first</b>	
	<b>In second</b>	
	<b>In third</b>	
	<b>In fourth</b>	
	<b>In reverse</b>	
<b>Constant mesh gears in 2nd (yes, no)</b>		
<b>Spur gear used in (indicate speeds)</b>		
<b>Helical gears used in (indicate speeds)</b>		
<b>Synchronous meshing in 2nd and 3rd gears (yes, no)</b>		

# AMA Consolidated Specification Questionnaire

**MAKE OF CAR** CADILLAC **MODEL YEAR** 1954

**MODEL** ALL

**DRIVE UNITS—CONVENTIONAL TRANSMISSION (cont.)** N.A.

<b>Lubricant</b>	Capacity (pt.)		
	Type recommended		
	SAE viscosity number	Summer	
		Winter	
Extreme cold			

**DRIVE UNITS—CONVENTIONAL TRANSMISSION WITH OVERDRIVE**

For transmission data see conventional transmission section N.A.

<b>Overdrive</b>	Type (planetary or other)			
	If planetary, No. of pinions			
	Manual lockout (yes, no)			
	Downshift accelerator control (yes, no)			
	Minimum cut-in speed			
	Gear ratio			
	<b>Lubricant</b>	Capacity (O.D. only)		
		Separate filter (yes, no)		
		Type recommended		
		SAE viscosity number	Summer	
Winter				
Ext. cold				

**DRIVE UNITS—AUTOMATIC TRANSMISSION**

<b>Trade name</b>	HYDRAMATIC - DUAL RANGE
<b>Type (fluid coupling with gears, torque converter with gears, other)</b>	FLUID COUPLING WITH GEARS
<b>Manual selector positions, left to right (show symbols and define, e.g., N- Neutral)</b>	N - NEUTRAL DR- FIRST POSITION (1-2-3-4 SHIFT) SECOND " (1-2-3 SHIFT) LO--LOW RANGE R - REVERSE
<b>List gear ratios in each drive position (range)</b>	LOW - 3.819 SECOND - 2.634 THIRD - 1.450 FOURTH - DIRECT REVERSE - 4.034
<b>Shifting within drive position range by accelerator control and speed limiting governor (yes, no)</b>	YES
<b>By governor—forced shift (yes, no)</b>	YES
<b>Downshift of gears in high range possible up to (mph)</b>	4-3 TO APPROX. 70 MPH -- 3-2 TO APPROX. 25 MPH

# AMA Consolidated Specification Questionnaire

**MAKE OF CAR** CADILLAC **MODEL YEAR** 1954

**MODEL** 62-60 75

## DRIVE UNITS—AUTOMATIC TRANSMISSION (cont.)

<b>Torque convertor</b>	Number of elements		
	Max. ratio at stall at engine rpm		
	<b>Mechanical lockup</b>	Provided (yes, no)	
		Speed range	
		Releases at (speed range, mph)	
	Type of cooling (forced air, oil cooler and type, other)		
Anti-creep device (yes, no)			
<b>Lubricant</b>	Capacity—refill (pt.)		22 PTS. REFILL
	Type recommended		TYPE A - AQATF OR CAD. HYD. FLUID
	<b>Grade</b>	Summer	
		Winter	
Extreme cold			

## DRIVE UNITS—PROPELLER SHAFT

Number used		1	2
Type (exposed, torque tube)		EXPOSED	
<b>Outer diameter x length* x wall thickness</b>	Conventional trans.		
	Overdrive trans.		
	Automatic trans.	2.5 x 52.66 x .065 - SER. 62 2.5 x 56.66 x .065 - SER. 60	2.5 - 2.25 x 27.59 x .065 FRT. SHAFT 2.5 - 2.25 x 44.94 x .065 REAR SHAFT
<b>Intermediate bearing</b>	Type (plain, anti-friction)	--	ANTI-FRICTION
	Lubric. (fitting, prepack)	--	PRE-PACKED
<b>Universal joints</b>	Make	MECHANICS & SAGINAW	MECHANICS
	Number used	2	3
	Type (ball and trunnion, cross, other)	CROSS & TRUNNION	
	<b>Bearing</b>	Type (plain, anti-friction)	NEEDLE
Lubric. (fitting, prepack)		PRE-PACKED	
Drive taken through (torque tube or arms, spring)		SPRINGS	
Torque taken through (torque tube or arms, springs)		SPRINGS	

\*Centerline to centerline of joints ~~or centerline to centerline of joints~~

# AMA Consolidated Specification Questionnaire

**MAKE OF CAR** CADILLAC **MODEL YEAR** 1954

**MODEL** 60-62 75

### DRIVE UNITS—REAR AXLE

Type (semi-floating, other)		SEMI-FLOATING		
Gear type (hypoid, other)		HYPOID		
Gear ratio and No. of teeth	Conventional trans.	N.A.		
	Overdrive trans.	N.A.		
	Automatic trans.	* 3.07 & (3.36 AIR-COND.)	3.77	
Pinion adjustment (shim, other)		NONE		
Pinion bearing adj. (shim, other)		COLLAPSABLE SPACER		
Lubricant	Capacity (pt.)	5		
	Type recommended	G.M. 4655M HYPOID LUB.		
	SAE viscosity number	Summer	90	
		Winter	90	
		Extreme cold	80	

### DRIVE UNITS—WHEELS

Type (disc, other) ***		SLOTTED STEEL DISC. (WIRE WHEELS STD. ELDORADO)	
Rim (size and flange type)		15 x 6L	
Attachment	Type (bolt or stud)	STUD	
	Circle diameter	5"	
	Number and size	5-1/2 - 20	

### DRIVE UNITS—TIRES

Size and ply rating	Standard	8.00 x 15 - 4 PLY RATING - BLACK	8.20 x 15 - 6 PLY RATING - BLACK
	Optional	8.20 x 15 - 4 PLY RATING - WHITE	" " " " " - WHITE
Rev/mile at 30 mph		**	**
Inflation press. (cold)	Front	24	28
	Rear	24	28

### BRAKES—SERVICE

Type		HYDRAULIC DUO SERVO	
		BENDIX HYDROVAC (OPTIONAL)	
Booster type			
Effective area (sq. in.)		211.55	
Percent brake effectiveness—rear		44.2	
Drum	Diameter	Front	12"
		Rear	12"
	Type and material	COMPOSITE RIBBED CAST IRON	

\* 3.36:1 RATIO OPTIONAL

#### 60-62 SERIES

#### 75 SERIES

	<u>8.20 x 15</u>	<u>8.00 x 15</u>	<u>8.20 x 15</u>
** FIRESTONE	703.9	711.0	706.0
U.S. ROYAL	708.1	716.0	703.0
GOODRICH	706.4	714.3	700.0

\*\*\* WIRE WHEELS OPT.

# AMA Consolidated Specification Questionnaire

**MAKE OF CAR** CADILLAC **MODEL YEAR** 1954  
 REVISED 3-1-54

**MODEL** 60-62 75

## BRAKES—SERVICE (cont.)

<b>Brake lining</b>	Bonded or riveted			RIVETED
	Primary	Material		MOLDED ASBESTOS
		Size (length x width x thickness)	Front wheel	11.154 x 2.5 x .25
			Rear wheel	11.154 x 2.5 x .25
		Segments per shoe		1
	Secondary	Material		MOLDED ASBESTOS
		Size (length x width x thickness)	Front wheel	12.23 x 2.5 x .25
			Rear wheel	12.23 x 2.5 x .25
		Segments per shoe		1
	Wheel cylinder bore	Front	1 1/8"	
Rear		1"		
Master cylinder bore			1"	
Available pedal travel			5 21/32"	
Line pressure at 100 lb. pedal load			575	
Shoe clearance adjustment x			.010 TOP .015 BOTTOM	

## BRAKES—PARKING

Type of control		T-HANDLE
Location of control		LEFT OF STEERING COLUMN
Operates on		REAR SERVICE BRAKES
If separate from service brakes	Type (internal or external)	NONE
	Drum diameter	--
	Lining size (length x width x thickness)	--

## FRAME

Type and description	CHANNEL SIDE BARS WITH I-BEAM X-MEMBER
----------------------	--

## FRONT SUSPENSION

Type and description	INDEPENDENT COIL SUSPENSION
----------------------	-----------------------------

x - REVISED



# AMA Consolidated Specification Questionnaire

MAKE OF CAR CADILLAC MODEL YEAR 1954  
 REVISED 3-1-54

<b>MODEL</b>	60	62	75
--------------	----	----	----

## FRONT SUSPENSION (cont.)

<b>Spring</b>	Type	COIL		
	Material	9260 STEEL		
	Size (length x width x No. leaves or coil I.D.)	(1) 16.38 x 4	(2) - 16.62 x 4	16.88 x 4
	Spring rate (lb. per in.)	350	350	400
	Rate at wheel (lb. per in.)			
<b>Shock absorbers</b>	Normal load (lb. @ rated length)	2210 @ 10 1/16	2165 @ 10 1/16	2445 @ 10 5/16
	Manufacturer	DELCO PRODUCTS		
	Type (direct or lever)	HYDRAULIC DIRECT ACTING		
<b>Stabilizer</b>	Piston diameter	1"		
	Type (link, linkless, frameless)	LINK		
	Material	STEEL		

## STEERING

<b>Type used (Standard or optional)</b>	Mechanical	N.A.				
	Power	STANDARD				
<b>Wheel diameter</b>		18"				
<b>Turning diameter</b>	Outside front	Wall to wall (r. & l.)	48.6	47.3	54.1	
		Curb to curb (r. & l.)	46.3	45.1	51.5	
	Inside rear	Wall to wall (r. & l.)				
		Curb to curb (r. & l.)				
<b>Inside wheel angle with outside wheel at 20°</b>		22° 40'				
<b>Mechanical</b>	<b>Gear</b>	Type	N.A.			
		Make				
		Ratios	<b>Gear</b>			
			<b>Overall</b>			
<b>No. wheel turns</b>						
<b>Power</b>	<b>Type</b>		HYDRAULIC POWER			
	<b>Make</b>		SAGINAW			
	<b>Trade name</b>		CADILLAC POWER STEERING			
	<b>Gear</b>	<b>Type</b>		BALL NUT AND SECTOR		
		<b>Ratios</b>	<b>Gear</b>	19.2:1		
			<b>Overall x</b>	21.3:1		
	<b>Pump driven by</b>		CRANKSHAFT			
	<b>Overall torque ratio</b>		333:1 (AT PARKING)			
<b>Number wheel turns</b>		4				
<b>Linkage</b>	<b>Type</b>		PARALLEL DRAG LINK			
	<b>Location (front or rear of wheels)</b>		REAR			
	<b>Drag link (trans. or long)</b>		TRANSVERSE			
	<b>Tie rods (one or two)</b>		TWO			

(1) 6219 - 6237 - 37D  
 (2) 6019 - 6267 - 67S

# AMA Consolidated Specification Questionnaire

MAKE OF CAR CADILLAC MODEL YEAR 1954

<b>MODEL</b>	60	62	75
--------------	----	----	----

## STEERING (cont.)

<b>Kingpin</b>	Inclination at camber (deg.)		5° 51' @ 0 CAMBER
	Diameter		1"
	Bearings (type)	Upper	BRONZE
		Lower	"
Thrust		BALL	
<b>Wheel alignment (range and preferred)</b>	Caster (deg.)		0 TO -1°
	Camber (deg.)		-3/8° TO +3/8°
	Toe-in (outside tread-inches)		3/16 - 1/4
<b>Steering knuckle type</b>			REVERSE ELLIOT
<b>Wheel spindle</b>	Diameter	Inner bearing	2.9630
		Outer bearing	2.25
	Thread size		3/4 - 20 NS-3
	Bearing type		BALL

## REAR SUSPENSION

<b>Type</b>		LEAF			
<b>Drive and torq. taken through (see page 14)</b>		REAR SPRINGS			
<b>* Spring</b>	<b>Type</b>		SEMI-ELLIPTIC		
	<b>Material</b>		SAE 9260	OR	SAE 5155 STEEL
	<b>Size (length x width x No. leaves or coil I.D.)</b>		56 1/2 x 2 1/2 x 5		56 1/2 x 2 1/2 x 6
	<b>Spring rate (lb. per in.)</b>		115 (1)	110 (2)	120 (3)
	<b>Rate at wheel (lb. per in.)</b>				140
	<b>Normal load (lb. at rated length) CAMBER</b>		1190 @ -.78 (1)	1160 @ -.78 (2)	1230 @ .78 (3)
	<b>Mounting insulation type</b>		RUBBER		
	<b>If leaf</b>	<b>No. of leaves</b>		5	6
		<b>Covers (yes, no)</b>		NO	
		<b>Lubricated (yes, no)</b>		NO	
<b>Inserts</b>		<b>Type and size</b>		FULL LENGTH	
		<b>Material</b>		WAX IMPREGNATED	
<b>Shackle (comp. or tens.)</b>		COMPRESSION LINK			
<b>Shock absorbers</b>	<b>Manufacturer</b>		DELCO		
	<b>Type (direct or lever)</b>		HYDRAULIC DIRECT ACTING		
	<b>Piston diameter</b>		1.0"		
<b>Stabilizer</b>	<b>Type (link, linkless, frameless)</b>		NONE		
	<b>Material</b>		"		
<b>Track bar type</b>		"			

\* (1) 6019, 6237D  
 (2) 6219, 6237  
 (3) 6267, 6267S

# AMA Consolidated Specification Questionnaire

Page 19  
Rev. 8-53

MAKE OF CAR CADILLAC MODEL YEAR 1954

## BODY—GENERAL DEFINITIONS

NOTE: Included in the dimension definitions listed on this and the following pages are those which have been proposed for adoption by the SAE. These are indicated by a number following the type of dimension, e.g., L 3. Additional dimensions have been added by the AMA Specifications Body Sub-Committee for inclusion in the Questionnaire. These are shown by an additional letter, e.g., HA. The dimensions are developed from the following basic points:

1. Front and rear seat "A" points are taken 5" forward of vertical tangent to seat back 15" from center of body.
2. Front seat is in the rear position.
3. Loaded position—5 passengers, front 300 lb., rear 450 lb., includes spare wheel, tire and tools, and full complement of gas, oil, water, etc. and tires to recommended pressure, etc.
4. C. L. (centerline).
5. D. L. O. (daylight opening, exposed glass dimension).
6. Ramp breakover angle (page 20-A) is the supplement of the included ramp angle (180° minus the included ramp angle) over which a car can pass without hanging up.

MODEL	6267 6237D	6219	6267S 6267	6019	75
-------	---------------	------	---------------	------	----

## BODY—TRUNK OPENING DIMENSIONS

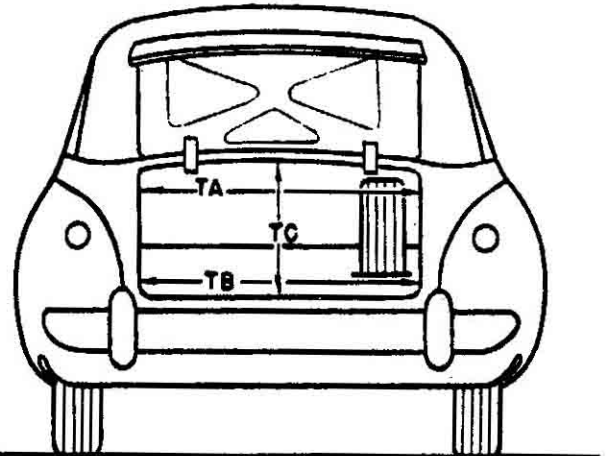
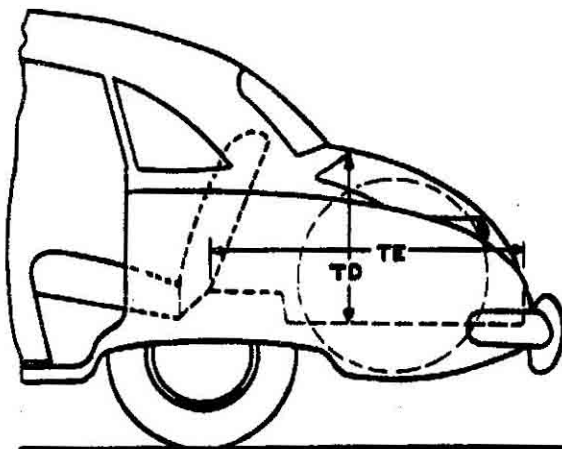

TA—Width across the top	N. A.
TB—Width across the bottom	N. A.
TC—Diagonal dimension at CL from top of opening to bottom	N. A.
TD—Vertical height of opening (floor to top, inside edge of opening)	N. A.
TE—Max. horizontal depth (forward from vertical projection of inside edge of opening)	N. A.
Position of spare tire stowage	VERTICAL
Method of holding lid open	COUNTER BALANCED SPRING

# AMA Consolidated Specification Questionnaire

MAKE OF CAR CADILLAC MODEL YEAR 1954

<b>MODEL</b>	6237 - 37D	6219	6267 6267S	6019	75
--------------	------------	------	---------------	------	----

## BODY—HEIGHT DIMENSIONS—INTERIOR

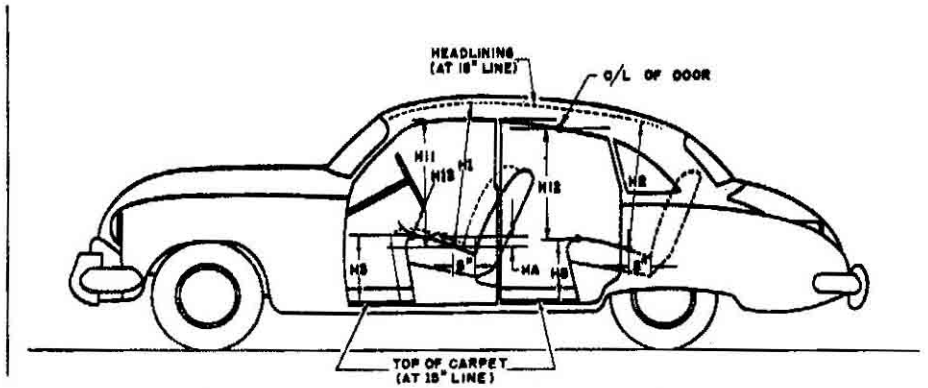

<b>H1.</b> Front headroom—from "A" pt. to headlining at 8° back of vertical on 15" line. (For "A" pt. see note 1, page 19)	34.0 (37) 34.3 (37D)	35.8	34.9	35.8	36.7
<b>H2.</b> Rear headroom—from "A" pt. to headlining at 8° back of vertical on 15" line.	34.4	35.6	34.2	35.6	35.5
<b>H3.</b> Front seat height to floor carpet on 15" line (front edge of cushion).	14.9	14.8	14.9	14.8	14.6
<b>H8.</b> Rear seat height to floor carpet on 15" line (front edge of cushion).	12.0	12.3	12.0	12.3	14.8
<b>H11.</b> Entrance—front—cushion "A" point to bottom windcord vertical.	27.6	30.01	27.6	30.01	30.2
<b>H12.</b> Entrance—rear—top of cushion to bottom windcord vertical at C/L of rear door.	--	28.6	--	28.6	29.9
<b>H13.</b> Steering wheel clearance to seat cushion taken on arc.	5.4	5.4	5.4	5.4	5.7
<b>HA.</b> Front seat vertical rise at "A" pt. (Inches.)	.3	.3	.3	.3	.3

# AMA Consolidated Specification Questionnaire

Page 20-A  
Rev. 8-53

MAKE OF CAR CADILLAC MODEL YEAR 1954

MODEL	6237 - 37D	6219	6267 6267S	6019	75
-------	------------	------	---------------	------	----

## BODY—HEIGHT DIMENSIONS—EXTERIOR

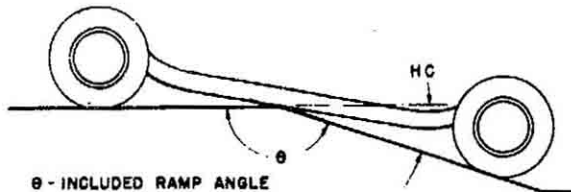
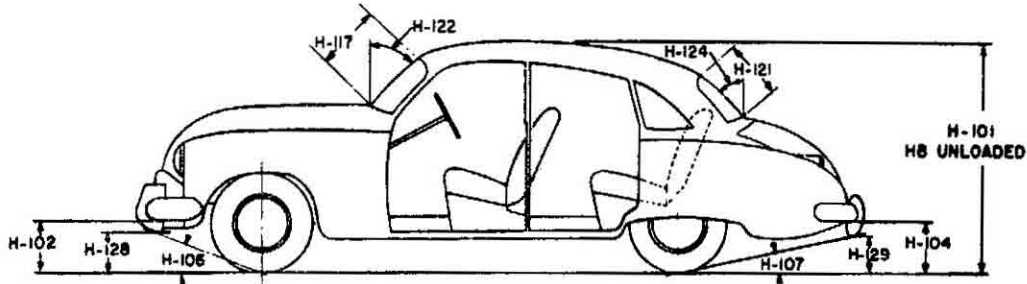

θ - INCLUDED RAMP ANGLE  
HC - RAMP BREAKOVER ANGLE  
(SUPPLEMENT OF INCLUDED RAMP ANGLE)

H101. Overall height.	59.6	62.1	60.1	62.1	63.9
HB. Overall height—unloaded.	61.7	64.1	62.2	64.1	66.2
H102. Front bumper bottom to ground at normal section.	9.0	9.0	9.0	9.0	10.1
H104. Rear bumper bottom to ground at normal section.	10.4	10.4	10.4	10.4	11.4
H106. Angle of approach—from the tire rolling radius to lowest point on front bumper or guard.	18°-35'	18°-35'	18°-35'	18°-35'	20°-52'
H107. Angle of departure—from the tire rolling radius to lowest point on rear bumper or guard.	11°-52'	13°-30'	11°-52'	11°-52'	14°-41'
HC. Ramp breakover angle.*	168°-24'	168°-24'	168°-24'	168°-34'	168°-24'
H117. Windshield DLO-slant height.	18.5	18.5	18.5	18.5	18.5
H121. Backlight DLO*—Max. slant height.	16.8	16.5	14	16.5	12.9
H122. Windshield slope angle to vertical line on car axis.	47	47	47	47	47
H124. Backlight slope angle to vertical line on car axis.	52°	47°	48°	47°	48°
H128. Ground to bottom of front bumper guard.	9.0	9.0	9.0	9.0	10.1
H129. Ground to bottom of rear bumper guard.	10.4	10.4	10.4	10.4	11.4
HD. Min. road clearance (location and dimension).	(1) 6.15	(1) 6.15	(2) 5.95	(1) 6.15	(3) 6.76
HE. Min. road clearance at rear axle.	7.55	7.55	7.55	7.55	7.67

\*See Notes, page 19.

- (1) KICK-UP - FRONT OF FRAME
- (2) REAR X-MEMBER
- (3) EXHAUST RESONATOR

# AMA Consolidated Specification Questionnaire

<b>MAKE OF CAR</b>	CADILLAC	<b>MODEL YEAR</b>	1954		
	REVISED 3-1-54				
<b>MODEL</b>	6237 6237D	6219	6267 6267S	6019	75

## BODY—LENGTH DIMENSIONS

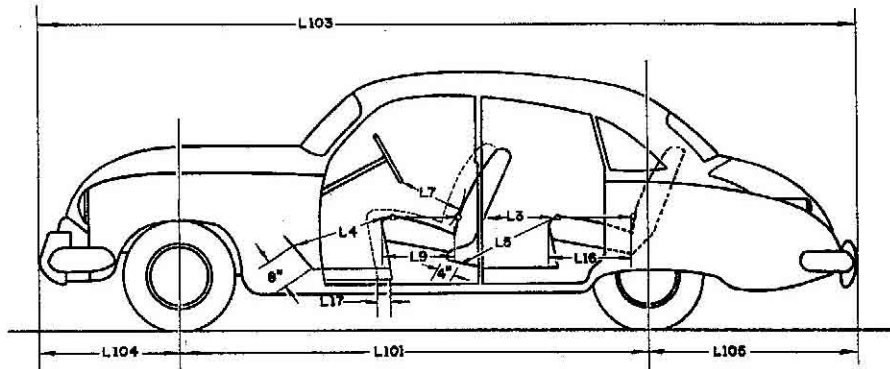

Interior	L3. Rear compartment back of front seat back to rear seat back.	32.2	35.8	31.4	35.8	52.7
	L4. Leg room—front—diagonal—ball of foot to top of seat to front seat back—15" line.	43.2	43.2	43.2	43.3	43.3
	L5. Leg room—rear—diagonal—from ball of foot to top of rear seat cushion and to seat back.	41.4	45.8	40.7	45.8	--
	L7. Steering wheel clearance to seat back taken on arc.	14.0	14.1	14.0	14.06	14.3
	L9. Front seat depth (front edge to vert. tan. to seat back on 15" line).	18.4	18.5	18.4	18.5	19.2
	L16. Depth of rear seat (front edge to seat back). x	19.1	18.8	19.7	18.8	19.9
	L17. Total adjustment of front seat at floor.	4	4	4	4	4
Exterior	L101. Wheel base.	129	129	129	133	149.8
	L103. Overall length (bumper to bumper inc. guards). x	223.4	216.4	223.4	227.4	237.2
	L104. Overhang—front including bumper guards.	34.9	34.9	34.9	34.9	34.9
	L105. Overhang—rear including bumper guards.	59.5	52.5	59.5	59.5	52.5

x - REVISED

# AMA Consolidated Specification Questionnaire

<b>MAKE OF CAR</b>	CADILLAC	<b>MODEL YEAR</b>	1954		
	REVISED 3-1-54				
<b>MODEL</b>	6237 6237D	6219	6267 6267S	6019	75

## BODY—WIDTH DIMENSIONS

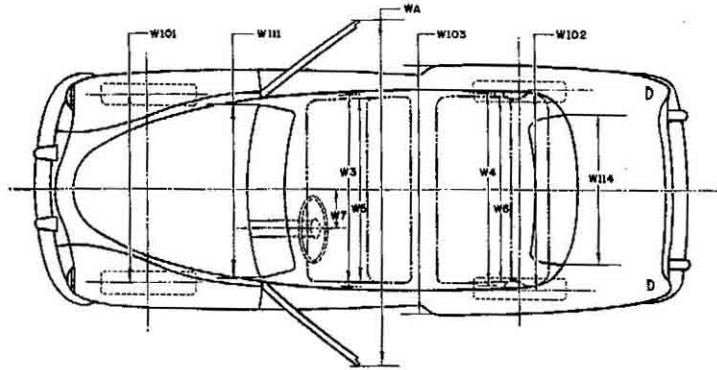

Interior	<b>W3.</b> Front shoulder room, at garnish moulding height or nearest interference 5" forward of seat back.	59.1	59.4	59.1	59.4	58.3
	<b>W4.</b> Rear shoulder room, at garnish moulding height or nearest interference 5" forward of seat back.	58.9	58.9	49.8	58.9	58.8
	<b>W5.</b> Front hip room, at top of seat 5" forward of vert. tan. to seat back.	63.9	64.3	63.9	64.2	64.1 (23) 64.4 (33)
	<b>W6.</b> Rear hip room, at top of seat 5" forward of vert. tan. to seat back.	56.4	65.2	53.3	65.2	59.4
	<b>W7.</b> Steering wheel center to center of body.	15.5	15.5	15.5	15.5	15.5
Exterior	<b>W101.</b> Front tread at ground.	60	60	60	60	60
	<b>W102.</b> Rear tread at ground.	63.1	63.1	63.1	63.1	63.2
	<b>W103.</b> Max. overall width of car including bumpers or mouldings.	79.6	79.6	79.6	79.6	79.6
	<b>WA.</b> Max. overall width of car with doors open.	142.2	135.0	142.2	135.0	135.0
	<b>W111.</b> Windshield DLO, max. width.                    x	61.0	61.0	61.0	61.0	61.0
	<b>W114.</b> Back window DLO, max. width.	61.4	58.4	46.5	58.4	38.4

x - REVISED

# AMA Consolidated Specification Questionnaire

MAKE OF CAR CADILLAC MODEL YEAR 1954

MODEL	6237 6237D	6219	6267 6267S	6019	75
-------	---------------	------	---------------	------	----

## BODY—MISCELLANEOUS INFORMATION

Doors hinged (front, rear)	Front	FRONT			
	Rear	"			
Type of finish (lacquer, enamel)	LACQUER				
Hood opening (front, side; semi-full, full, half)	FRONT				
Hood counterbalanced (yes, no)	YES				
Hood release control (internal, external)	EXTERNAL				
Vent window control method (crank, friction, pivot).	CRANK	FRICTION	CRANK		
	ONE PIECE CURVED				
	ONE PIECE CURVED				
Rear window type (one piece, two piece, three piece; curved, flat)	ONE PIECE CURVED	ONE PIECE FLAT	ONE PIECE CURVED	ONE PIECE FLAT	
Windshield glass area	1148				
Backlight glass area					
Total glass area					

## BODY—TYPES AND STYLE NAMES

Body type, number of passengers, and style names (use letter code shown below followed by passenger capacity and style name e.g., N-6 Ranchwagon)	62 SERIES	6219 - H-5 SEDAN
		6237 - J-5 COUPE
		6237D- J-5 COUPE DEVILLE
		6267 - L-5 CONVERTIBLE
		6267S- L-5 CONVERTIBLE EL'DORADO
	60 SERIES	6019 - H-5 SEDAN
	75 SERIES	7523 - H-8 SEDAN
		7533 - T-8 IMPERIAL SEDAN

### Body type code

- |  |   |
|--|---|
| A—Coupe—2 door flatback<br>B—Coupe—2 door notchback<br>C—Sedan—2 door flatback<br>D—Sedan—2 door notchback<br>E—Sedan—4 door flatback (4 windows)<br>F—Sedan—4 door flatback (6 windows)<br>G—Sedan—4 door notchback (4 windows)<br>H—Sedan—4 door notchback (6 windows)<br>J—Hardtop—2 door<br>K—Hardtop—4 door | L—Convertible—2 door<br>M—Convertible—4 door<br>N—Station wagon—2 door<br>P—Station wagon—4 door<br>Q—Combined passenger and utility—2 door<br>R—Combined passenger and utility—4 door<br>S—Sedan delivery<br>T—Limousine |
|--|---|



## INDEX

SUBJECT	PAGE	SUBJECT	PAGE
Battery.....	8	Kingpin.....	18
Belts, drive.....	7	Lamp bulbs.....	11
Body		Linings—clutch, brake.....	12, 16
General Body Information.....	19, 23	Lubrication.....	5, 6, 13, 14, 15
Height dimensions.....	20	Muffler.....	6
Length dimensions.....	21	Overdrive.....	13
Overall dimensions.....	1	Piston pins.....	3
Trunk opening dimensions.....	19	Pistons.....	2
Width dimensions.....	22	Propeller shaft.....	14
Types.....	23	Radiator, radiator hoses.....	7
Brakes		Rear axle.....	1, 15
Parking.....	16	Rims.....	15
Service.....	15, 16	Rings.....	3
Camber.....	18	Shock absorbers	
Camshaft.....	4	Front.....	17
Capacities		Rear.....	18
Cooling system.....	7	Spark plugs.....	9
Fuel tank.....	6	Springs	
Lubricants		Front.....	17
Crankcase.....	6	Rear.....	18
Overdrive.....	13	Valve.....	5
Transmissions.....	13, 14	Stabilizer	
Rear axle.....	15	Front.....	17
Carburetor.....	6	Rear.....	18
Caster.....	18	Valve.....	5
Choke, automatic.....	6	Starting motor.....	8
Circuit breakers.....	11	Steering.....	1, 17, 18
Clutch (pedal operated).....	12	Suppression.....	9
Coil, ignition.....	9	Suspension	
Connecting rods.....	3	Front.....	16, 17
Cooling system.....	7	Rear.....	18
Crankshaft.....	3, 4	Switches.....	10
Cylinders, cylinder head.....	2	Tailpipe.....	6
Distributor.....	9	Timing, engine.....	4, 5, 9
Electrical System.....	8, 9, 10, 11	Tires.....	1, 15
Engine		Toe-in.....	18
Bore and stroke, displacement.....	1, 2	Torque converter.....	14
Compression ratio.....	1, 2	Torque, maximum.....	1, 2
Firing order, cylinder numbering.....	2, 9	Transmission	
General information.....	1, 2	Automatic.....	13, 14
Lubrication.....	5, 6	Conventional.....	12, 13
Type.....	1, 2	Conventional with overdrive.....	13
Exhaust system.....	6	Ratios.....	12
Fan.....	7	Types.....	1, 12, 13
Frame.....	16	Tread.....	1, 22
Fuel.....	6	Turning diameter.....	1, 17
Fuel pump.....	6	Universal joints.....	14
Fuel system.....	6	Valves, intake and exhaust.....	4, 5
Fuses.....	11	Voltage regulator.....	8
Generator.....	8	Water pump.....	7
Horns.....	10	Weight, shipping.....	1
Horsepower		Wheel alignment.....	18
Maximum brake.....	1, 2	Wheelbase.....	1, 21
Taxable.....	2	Wheels.....	15
Ignition system.....	9	Wheel spindle.....	18
Instruments.....	10	Windshield wiper.....	10