

AUTOMOBILE MANUFACTURERS ASSOCIATION CONSOLIDATED SPECIFICATION QUESTIONNAIRE

MAKE OF CAR: CHEVROLET	MODEL NAME	SYMBOL
COMPANY: Chevrolet Motor Division General Motors Corporation Engineering Center Box 246 N. End Station Detroit 2, Michigan	Corvette	2934
MODEL YEAR: 1957 DATE 9-1-56		

Revised: 12-5-56; 12-27-56

TABLE OF CONTENTS

General Specifications.....	1	Frame.....	16
Engine.....	2	Front Suspension.....	16
Electrical.....	8	Steering.....	17
Drive Units.....	12	Rear Suspension.....	18
Brakes.....	15	Body.....	19
Index.....	24		

- NOTES: 1. The specifications set forth herein are those in effect at the date of compilation and are subject to change without notice.
 2. All specifications are standard for the models under which they are listed unless otherwise indicated.
 3. All dimensions are nominal engineering dimensions unless otherwise indicated.
 4. Unless otherwise indicated, specifications apply to 5 or 6 passenger, 4-door sedan or equivalent.

GENERAL SPECIFICATIONS

Model		V-6	
		Conventional	Powerglide
Wheelbase		102.00	
Tread	Front	57.00	
	Rear	59.00	
Maximum Overall Dimensions	Length (L-103)	168.01	
	Width (W-103)	70.46	
	Height (H-101)	51.09	
Steering ratio—overall		16:1	
Turning diameter (curb to curb)		Right 36.55	Left 36.93
Shipping weight*		2737 lbs. (Est.)	2829 lbs. (Est.)
Transmission— (Specify standard, optional, not avail.)	Conventional	3-Speed Standard; 4-Speed Optional	
	Overdrive	None	
	Automatic	Optional	
Axle ratio	Conventional	3.70:1 (Optional 3.70:1, 4.11:1, 4.56:1) (b)	
	Overdrive	None	
	Automatic	3.55:1	
Tire size		6.70-15-1 Ply Rating	
Engine	Type	V-6	
	No. of cylinders	8	
	Valve arrangement	In Head	
	Bore and stroke	3.875 x 3.00	
	Piston displacement, cu. in.	283	
	Standard compression ratio	9.5:1 (10.5:1 with Fuel Injection & Opt. Camshaft)	
	Maximum bhp at engine rpm	220 @ 4800 (a)	
Maximum torque at rpm	300 @ 3000 (a)		

*Standard car weight, not including gas and water.

- (a) - See page 24.
 (b) - See page 15.

AMA Consolidated Specification Questionnaire

Page 2
 Issued: 9-1-56
 Revised: 12-5-56

MAKE OF CAR Chevrolet MODEL YEAR 1957

MODEL Corvette V-8
Conventional Powerglide

ENGINE—GENERAL

Type	V, In-line, other		V
	Angle of V		90°
No. of cylinders			8
Valve arrangement			In Head
Bore and stroke			3.875 x 3.00
Piston displacement, cu. in.			283
Numbering system (front to rear)	L. Bank		1-3-5-7
	R. Bank		2-4-6-8
Firing order			1-8-4-3-6-5-7-2
Compression ratio	Standard Head	9.5:1 (10.5:1 with Fuel Injection & Opt. Camshaft)	
	Optional Head	None	
Cylinders	Head	Standard	Cast Alloy Iron
	Material	Optional	None
	Sleeve—Wet, dry, other, none		None
Number of mounting points	Front		2
	Rear		2
Taxable horsepower	(Dia. ² x No. Cyl.)	2.5	1.8
Advertised max. brake horsepower at engine RPM*	Standard head		220 @ 1,800 (a)
	Optional head		None
	With fuel (Octane and method)	Standard Head	87-92 Octane (Research) (b)
		Optional Head	None
Max. torque (lb. ft. @ RPM)	Standard head		300 @ 3000 (a)
	Optional head		None
Recommended idle speed (neutral)	475 in Neutral		125 in Drive

ENGINE—PISTONS

Material	Cast Aluminum Alloy with Steel Struts		
Description and finish	Machined Relief for Valve Head Clearance (Domed Piston with Machined Reliefs used with Fuel Inj. & Opt. Camshaft)		
Weight (piston only) oz.	21.12		
Clearance	Top land	.035 - .043	
	Skirt	Top	.0006 - .0010 (c)
		Bottom	NA
Ring groove depth	No. 1 ring	.2153 - .2218	
	No. 2 ring	.2153 - .2218	
	No. 3 ring	.2093 - .2158	
	No. 4 ring	None	

*Corrected as defined by SAE Engine Test Code, with the following standard power consuming accessories: Dynamometer Exhaust, Water Pump, NO fan, Generator not charging.

- (a) - See page 2a.
- (b) - With fuel injection & optional camshaft, 96-99 Octane (Research)
- (c) - Measured 2.44 inches from top of piston: .0016 - .0020 with dual four barrel carburetor or fuel injection equipment.

AMA CONSOLIDATED SPECIFICATION QUESTIONNAIRE

Make of Car Chevrolet Model Year 1957Model Corvette

ENGINE GENERAL (Continued)

With Two Four-Barrel Carburetor Equipment:

Maximum bhp at engine rpm	245 @ 5000
Maximum torque at rpm	300 @ 3800

With Fuel Injection Equipment:

Maximum bhp at engine rpm	250 @ 5000
Maximum torque at rpm	305 @ 3800

With Two Four-Barrel Carburetor and Competition Camshaft Equipment:

Maximum bhp at engine rpm	270 @ 6000
Maximum torque at rpm	285 @ 4200

With Fuel Injection and Competition Camshaft Equipment:

Maximum bhp at engine rpm	283 @ 6200
Maximum torque at rpm	290 @ 4400

AMA Consolidated Specification Questionnaire

Page 3
 Issued: 9-1-56
 Revised: 12-5-56

MAKE OF CAR Chevrolet MODEL YEAR 1957

	V-8	
MODEL <u>Corvette</u>	Conventional	Powerglide

ENGINE—RINGS

Type (top to bottom)	No. 1 oil or comp.	Compression
	No. 2 oil or comp.	Compression
	No. 3 oil or comp.	Oil
	No. 4 oil or comp.	None
No. rings above piston pin		3
Compression	Material	Cast Alloy Iron
	Coating	Upper Chrome Plate Lower-Wear Resistant Coating
	Width	.0770 - .0785
	Gap	.010 - .020
	Maximum wall thickness	.194
Oil	Material	Rails, Steel; Expander, Stainless Steel
	Coating	Rails Chrome Plated OD
	Width	.181 - .188
	Gap	.015 - .055
	Maximum wall thickness	.168
Location of expanders		In Oil Ring Assy.

ENGINE—PISTON PINS

Material		Chrome Steel (File Hard Case)
Length		2.990 - 3.010
Diameter		.9270 - .9273
Type	Locked in rod, in piston, floating, etc.	Pressed in Rod
	Bushing	None
		None
Clearance	In piston	.00015 - .00025
	In rod	None
Direction offset in piston		Major Thrust Side

ENGINE—CONNECTING RODS

Material		Forged Steel
Weight (oz.)		19.02
Length (center to center)		5.699 - 5.701
Bearing	Material	Stl. Backed Al Alloy Matrix with a Thin Lead Alloy Overplate
	Type (cast-in or removable)	Removable
	Effective length	.817
	Clearance	.0007 - .0027
	End play	.008 - .011

ENGINE—CRANKSHAFT

Material		Forged Steel
Weight (lb.)		1.8

AMA Consolidated Specification Questionnaire

Page 4
 Issued: 9-1-56
 Revised: 12-5-56

MAKE OF CAR Chevrolet MODEL YEAR 1957

	V-8	
MODEL <u>Corvette</u>	Conventional	Powerglide

ENGINE—CRANKSHAFT (cont.)

Vibration damper type		Inertia (Rubber Mounted)	
End thrust taken by bearing (No.)		5	
Crankshaft end play		.002 - .006	
Main bearing	Material	Steel backed aluminum alloy matrix with a thin lead alloy overplate, except rear main of steel backed babbitt	
	Type (cast-in or removable)	Removable	
	Clearance	.0008 - .0034	
	Journal dia. and bearing effective length	No. 1	2.2983 x .7620
		No. 2	2.2983 x .7620
		No. 3	2.2983 x .7620
		No. 4	2.2983 x .7620
		No. 5	2.2983 x 1.169
No. 6		None	
No. 7		None	
Direction offset from cyl. bore		None	
Connecting rod crankpin journal diameter		1.999 - 2.000	

ENGINE—CAMSHAFT

Material		Cast Alloy Iron	
Bearings	Material	Babbitt on a Steel Backed Aluminum Shell	
	Number	5	
Type of drive	Gear or chain		Chain and Sprocket
	Crankshaft gear or sprocket material		Steel
	Camshaft gear or sprocket material		Cast Alloy Iron
	Timing chain	Make	Link Belt
		No. of links	46
		Width	.875
Pitch		.500	

ENGINE—VALVE SYSTEM

Hydraulic lifters (yes, no)		Yes (a)
Special provision for valve rotation (intake, exhaust)		None
Rocker ratio		1.5:1
Operating tappet clearance (indicate hot or cold)	Intake	Zero (b)
	Exhaust	Zero (c)
Tappet clearance for timing	Intake	Zero
	Exhaust	Zero
Timing marks on fly-wheel, damper, other		Damper

- (a) - Mechanical tappets on engines equipped with optional camshaft.
- (b) - .012 hot with mechanical tappets.
- (c) - .018 hot with mechanical tappets.

AMA Consolidated Specification Questionnaire

Page 5
 Issued: 9-1-55
 Revised: 12-5-56

MAKE OF CAR Chevrolet MODEL YEAR 1957

MODEL Corvette V-8
Conventional Powerglide

ENGINE—VALVE SYSTEM (cont.)

Timing	Intake	Opens (°BTC)	12° 30' (with Optional Camshaft-35°)	
		Closes (°ABC)	57° 30' (With Optional Camshaft - 72°)	
	Exhaust	Opens (°BBC)	51° 30' (With Optional Camshaft - 76°)	
		Closes (°ATC)	15° 30' (With Optional Camshaft - 31°)	
Intake	Material		Alloy Steel	
	Overall length		4.902 ₁ - 4.922 ₁ (a)	
	Actual overall head dia.		1.715 - 1.725	
	Angle of seat		45°	
	Seat insert material		None	
	Stem diameter		.3415 - .3422	
	Stem to guide clearance		.0010 - .0027	
	Lift		.3987 (.3938 with Optional Camshaft)	
	Outer spring press. and length	Valve closed (lb. @ in.)	1.696 @ 67-79 Lb.	
		Valve open (lb. @ in.)	1.30 @ 159-169 Lb.	
	Inner spring press. and length	Valve closed (lb. @ in.)	Valve Spring Damper 5-10 Lb.	
		Valve open (lb. @ in.)	None	
	Exhaust	Material		Alloy Steel
		Overall length		4.913 - 4.933 (b)
Actual overall head dia.		1.495 - 1.505		
Angle of seat		45°		
Seat insert material		None		
Stem diameter		.3410 - .3417		
Stem to guide clearance		.0015 - .0032		
Lift		.3987 (.3997 with Optional Camshaft)		
Outer spring press. and length		Valve closed (lb. @ in.)	69-79 Lb. @ 1.696 in.	
		Valve open (lb. @ in.)	159-169 @ 1.306 in.	
Inner spring press. and length		Valve closed (lb. @ in.)	Valve Spring Damper 5-10 Lb.	
		Valve open (lb. @ in.)	None	

ENGINE—LUBRICATION SYSTEM

Type of lubrication (splash, pressure, nozzle)	Main bearings	Pressure
	Connecting rods	Pressure
	Piston pins	Pressurized Jet Cross Sprayed
	Camshaft bearings	Pressure
	Tappets	Pressure
	Timing gear or chain	Pressure
	Cylinder walls	Pressurized Jet Cross Sprayed

- (a) - With Fuel Injection & Optional Camshaft or dual 4-barrel & Optional Camshaft-
 4.8699 - 4.8899.
- (b) - With Fuel Injection & Optional Camshaft or dual 4-barrel & Optional Camshaft-
 4.8905 - 4.9105.

AMA Consolidated Specification Questionnaire

Issued: 9-1-56
Revised: 12-5-56
12-27-56

MAKE OF CAR Chevrolet MODEL YEAR 1957

MODEL Corvette V-8
Conventional Powerglide

ENGINE—LUBRICATION SYSTEM (cont.)

Oil pump type	Gear
Normal oil pressure (lb. @ rpm)	30 PSI @ 1170-1200
Oil pressure gage type (electric or mechanical)	Electric
Type oil intake (floating, stationary)	Stationary
Oil filter type (full flow, partial flow)	Full Flow
Capacity of crankcase, less filter—refill (qt.)	5 Quart
Oil grade recommended (SAE viscosity and temperature range)	Not lower than 32° F ————— SAE 20W or SAE 20 Not lower than 0° F ————— SAE 10W or SAE 10W- Lower than 0° F ————— SAE 5W or SAE 5W-20
Oil type recommended	Heavy Duty

ENGINE—FUEL SYSTEM

Recommended fuel	Standard head	Regular Grade (Premium Grade with Fuel Inj. & Opt. Camshaft)	
	Optional head	None	
Fuel Tank	Capacity (gals.)	16.4	
	Filler Location	Left Side of Body to Rear of Drivers Door	
Fuel Filter	Type	Strainer	
	Location	Ahead of Carburetor	
	Type (elec. or mech.)	Mechanical	
Fuel pump	Location	Lower Right Front Corner of Engine	
	Pressure range	4-3/4 - 5-1/2 PSI	
	Vacuum booster (std., opt., none)	None	
	Make	Carter or Rochester	
	Model number	3744925 (a)	
	Number used	1	
Carburetor	Type	Downdraft, side inlet, other	Downshaft
		Single or dual	4-Barrel
	Intake manifold heat control (manual, auto., none)	Automatic	
	Automatic choke type (integral, other)	Integral	
	Air cleaner type	Standard	Oil Wetted
		Optional	Dry with Paper Element (b)

ENGINE—EXHAUST SYSTEM

Type (single, single with cross-over, dual, other)	Dual	
Muffler type (rev. flow, str. thru, sep. resonator)	Straight Turn	
Exhaust pipe dia.	Branch	None
	Main	2.00 OD
Tail pipe diameter	1.81 ID	

(a) - Dual four barrel carburetors or fuel injection optional.
 (b) - Used with Fuel Injection equipment only.

AMA CONSOLIDATED SPECIFICATION QUESTIONNAIRE

Issued: 9-1-56
 Revised: 12-5-56
 12-27-56

Make of Car CHEVROLET Model Year 1957

Model CORVETTE

ENGINE FUEL SYSTEM-FUEL INJECTION

Injection System	Make	Rochester Products
	Model	7014520 (7014360 with Optional Camshaft)
	Type	Constant Flow
Fuel Recommended		Premium
Fuel Pump	Type	Mechanical
	Location	Lower Right Front Corner of Engine
	Pressure Range	4-3/4 - 5-1/2 PSI
Auxiliary Fuel Filter	Type	Ten Micron
	Location	Bracketed to Engine Top Cover
Inlet Manifold Adapter-Material		Aluminum
Inlet Manifold-Material		Cast Aluminum
Air Induction (a)	Air Cleaner Type	Dry (Paper Element)
	Air Meter Location	Left Side of Engine
	Plenum Chamber	Integral with Inlet Manifold
	Ram Pipes	Eight, Integral with Inlet Manifold
	Ram Pipe Length	12 Inches
Fuel Induction		Metered as Function of Air Flow
Air/Fuel Ratio Control		Vacuum Sensitive Diaphragm Located on Fuel Meter
Fuel Cut-off Control		Vacuum Sensitive Diaphragm Located above Fuel Meter
Fuel Meter Pump	Type	Gear Type
	Location	In Fuel Meter Assembly
	Drive	Gear Driven by Flexible Shaft from Distributor
	Pressure (Max.)	300 PSI
Injection Nozzles	Number Used	Eight
	Material	Brass
	Location	Mounted on Inlet Manifold above Intake Ports
	Orifice Size-Fuel	.011
	Insulation	Bakelite Block
Automatic Choke	Type	Electric, Time-Temperature Type
	Location	On Air Meter Assembly
	Current Draw	Low Current Draw
	Fast Idle Cam	Yes

(a) - Air Intake Ducts which channel outside air to the Engine Compartment are available with the Fuel Injection Option.

AMA Consolidated Specification Questionnaire

Page 7
 Issued: 9-1-56
 Revised: 12-5-56

MAKE OF CAR Chevrolet MODEL YEAR 1957

MODEL Corvette V-8
Conventional Powerglide

ENGINE-COOLING SYSTEM

Type (pressure system, atmospheric, other)		Pressure	
Radiator cap relief valve press.		6-1/4 - 7-1/2 PSI	
Circulation thermostat	Type (choke, bypass)	Choke	
	Starts to open at	160°	
Water pump	Type (centrifugal, other)	Centrifugal	
	Number of pumps	One	
	Drive (V-belt, other)	V-Belt	
	Bearing type	Permanently Lubricated, Double Row Ball Bearing	
By-pass recirculation type (internal, external)		Internal	
Radiator core type (cellular, tube and fin)		Cellular	
Cooling system capacity	With heater (qt.)	17	
	Without heater (qt.)	16	
Water jackets full length of cylinder (yes, no)		Yes	
Water all around cylinder (yes, no)		Yes	
Radiator hose	Lower	Number and type (molded, straight)	One, Molded
		Inside diameter and length	1-3/4 x 15
	Upper	Number and type (molded, straight)	One, Molded
		Inside diameter and length	1-1/2 x 16.50
	By-pass	Number and type (molded, straight)	None
		Inside diameter and length	None
Drive belts	Fan	Number used	One
		Angle of V	37° - 44°
		Outside length	54-3/4
	Generator	Width	5/16
		Angle of V	37° - 44°
		Outside length	54-3/4
Fan	Number of blades and spacing		1, Staggered
		Diameter	17
	Ratio—fan to crankshaft revolutions		.949:1
		Bearing type	Permanently Lubricated Double Row Ball

AMA Consolidated Specification Questionnaire

Page 8

Issued: 7-1-56^{sz}

Revised: 12-5-56

MAKE OF CAR Chevrolet MODEL YEAR 1957

MODEL <u>Corvette</u>	<u>V-8</u>	
	<u>Conventional</u>	<u>Powerglide</u>

ELECTRICAL—SUPPLY SYSTEM

Battery	Make and Model		<u>Delco, 2 SBR 53-W</u>
	Voltage Rtg. & Plates/cell		<u>12 Volt, 9 Plate</u>
	SAE Designation & Amp Hr. Rtg		<u>2SM, 53 Amp. Hrs. @ 20 Hr. Rate</u>
	Location		<u>Under Hood Right Side Rear</u>
	Terminal grounded		<u>Negative</u>
Generator	Make		<u>Delco-Remy</u>
	Model		<u>1120043</u>
	Type		<u>2 Brush, Shunt Wound</u>
	Ratio—Gen. to Cr/s rev.		<u>2.00:1</u>
Regulator	Make		<u>Delco-Remy</u>
	Model		<u>1119001</u>
	Type		<u>Current & Voltage Control</u>
	Cutout relay	Closing voltage @ generator rpm	<u>12.8 @ 1300</u>
		Reverse current to open	<u>NA</u>
	Regulated	Voltage	<u>14.5</u>
		Current	<u>30 Amp.</u>
	Min. Gen. rpm required		<u>(For Max. Output) 2950</u>
	Voltage test conditions	Temperature	<u>Operating (Run Gen. 15 Min. @ 8-10 Amps. Before Testing)</u>
		Load	<u>10 Amps Max.</u>
Other		<u>None</u>	

ELECTRICAL—STARTING SYSTEM

Starting motor	Make		<u>Delco-Remy</u>
	Model		<u>1107664</u>
	Rotation (drive end view)		<u>Clockwise</u>
	Engine cranking speed		<u>NA</u>
	Test conditions		<u>Engine at Operating Temperature</u>
	Lock test	Amps	<u>NA</u>
		Volts	<u>NA</u>
		Torque (lb. ft.)	<u>NA</u>
	No load test	Amps	<u>75 (Max.)</u>
		Volts	<u>10.3</u>
RPM (min.)		<u>6900</u>	
Motor control	Switch (solenoid, manual)		<u>Solenoid</u>
	Starting procedure	Place shift in neutral Depress Clutch	Place selector lever in park or neutral
		Depress accelerator pedal to floor to set automatic choke, release. Turn ignition key to extreme right position to start engine.	

AMA Consolidated Specification Questionnaire

Page 9
 Issued: 9-1-56
 Revised: 12-5-56

MAKE OF CAR Chevrolet MODEL YEAR 1957

MODEL Corvette Conventional V-8 Powerglide

ELECTRICAL—STARTING SYSTEM (cont.)

Motor drive	Engagement type		Positive Shift Solenoid
	Pinion meshes (front, rear)		Front
	Number of teeth	Pinion	9
		Flywheel	168
Flywheel tooth face width		.4135	

ELECTRICAL—IGNITION SYSTEM

Coil	Make		Delco-Remy
	Model		1115091 (1115107 with Fuel Injection Equipment)
	Amps	Engine stopped	4
Engine idling		1.8	
Distributor	Make		Delco-Remy
	Model		1110891 (1110889 with Fuel Injection Equipment)
	Spark advance data (at distributor shaft)	Centr. advance start (rpm)	275
		Centr. advance max. deg. @ rpm	20° @ 1850
		Vacuum advance start (in. Hg.)	None
		Vac. adv. (max. deg. @ in. Hg.)	None
	Breaker gap (in.)		.018
	Cam angle (deg.)		29
Breaker arm tension (oz.)		19-23	
Timing	C/S deg. @ rpm		12° BTDC @ Idle (a)
	Mark location		Damper
	Cylinder numbering system (see page 2)		Left Bank 1-3-5-7; Right Bank 2, 4, 6, 8
	Firing order (see page 2)		1-8-4-3-6-5-7-2
Spark plug	Make and model		AC 114
	Thread (mm)		11
	Tightening torque (lb. ft.)		20-25
	Gap		.033 - .038
Cable	Conductor type		Linen core impregnated with an electrical conducting material
	Insulation type		Rubber with Neoprene jacket
	Spark plug protector		Neoprene Jacket

ELECTRICAL—SUPPRESSION

Description	Non-Metallic High Tension Cable
-------------	---------------------------------

(a) - Dual 4 Bbl. Carb. with Optional Camshaft & Fuel Inj. with Optional Camshaft-12° BTDC @ Idle.

AMA Consolidated Specification Questionnaire

Issued: ^{Page 10} 9-1-56
Revised: 12-5-56

MAKE OF CAR Chevrolet MODEL YEAR 1957

MODEL Corvette V-8
Conventional Powerglide

ELECTRICAL—INSTRUMENTS AND SWITCHES

Speed-ometer	Make	AC
	Trip odometer (yes, no)	No
Charge indicator—type		Ammeter
Temperature indicator—type		Electric
Oil pressure indicator—type		Bourdon Tube
Fuel indicator—type		Electric
Ignition switch	Identify positions in order and circuits controlled	Vertical ----- Off, unlocked Counter Clockwise ----- Off, locked 1st Pos. Clockwise from Vert. ----- Ignition & accessories on 2nd Pos. Clockwise from Vert. ----- Ignition & starter on with spring return to 1st position
	Provision for illumination	Yes
	Location	On Instrument Panel - Right of Steering Column
	Theft protection type	None
Main lighting switch	Identify positions and lights controlled	Depressed - Off 1st Notch - Instr. Panel Lights, Parking Lights 2nd Notch - Instr. Panel Lights, Driving Lights Rotate Clockwise to Dim and Turn Off Instr. Panel Lights; Counter Clockwise to Turn On and Brighten Panel Lights
Other light switches	Locations and lamps controlled	Toe Panel ----- Headlight Dimmer Glove Compartment ----- Glove Compartment Lamp Steering Column ----- Turn Signal Lamps Hinge Pillar ----- Courtesy Lamp On Brace Below Instr. Panel ----- Stop Lamps Parking Brake Lever Housing ----- Parking Brake Alarm Lamp
Other switches	Locations and devices controlled	Instrument Panel ----- Folding Top Instrument Panel ----- Electric Windshield Wipers LH Door ----- Electric Window Lifts Instrument Panel ----- Radio on-off Switch Instrument Panel ----- Heater & Blower Switch
Windshield wiper	Make	Delco (Motor Unit Trico)
	Type	Electric
	Vacuum booster provision	None
	Washer provision	Dealer Installed Accessory
Horn	Type	Vibrator
	Number used	2
	Amp draw (each)	High 9, Low 10

AMA Consolidated Specification Questionnaire

Page 11
Issued: 9-1-56
Revised: 12-5-56

MAKE OF CAR Chevrolet MODEL YEAR 1957

MODEL Corvette Conventional V-8 Powerglide

ELECTRICAL—LAMP BULBS

Give quantity used and trade number, e.g., Headlamp 2-4030. Indicate accessories which are not standard equipment by an asterisk following the numbers.

Headlamp		2-T-3-5400
Headlamp beam indicator		1-53
Parking light		2-1034 (Combination Parking & Directional Signal Lamp)
Tail light		2-1034 (Combination Tail, Stop & Directional Signal Lamp)
Stop light		(See "Tail Light")
Direction indicator	Front	(See "Parking Light")
	Rear	(See "Tail Light")
	Tell-Tale	None
License plate light		2-67
Instrument light		4-57
Ignition lock light		1-53
Map light		None
Dome light		None
Clock light		1-57
Radio dial light		1-GE 1891*
Glove compartment light		None
Courtesy light		2-90*
Trunk compartment light		None
Other		
Cigarette Lighter Lamp (1-53); Parking Brake Alarm Lamp (1-90)*		

ELECTRICAL—FUSE & CIRCUIT BREAKER DATA

Use trade number of fuse, e.g., SFE-10. Indicate circuit breaker by amperes capacity suffixed by letters "CB", e.g., 30 CB. Where fuse or circuit breaker protects multiple circuits indicate first use by a letter and repeat the same letter for all units protected by the same fuse or circuit breaker, e.g., Parking light: SFE-10 (a), Direction indicator: same as (a).

Headlamp		13 CB (a)
Headlamp beam indicator		Same as (a)
Parking light		Same as (a)
Tail light		Same as (a)
Stop light		Same as (a)
Direction indicator		Same as (a)
License plate light		Same as (a)
Instrument light		13 CB (a) & AGA-3 Fuse (b)
Ignition light		Same as (b)
Map light		None
Dome light		None
Clock		Same as (a)
Clock light		Same as (b)
Radio		SFE 7-1/2 & SFE 4
Glove compartment light		None
Courtesy light		Same as (a)
Trunk compartment light		None
Other		Windshield Wiper Motor, 10 CB; Power Window, 40 CB; Parking Brake Alarm SFE-9; Hydraulic Folding Top, 15 CB; Heater & Defroster, AGC-10; Cigarette Lighter Lamp, Same as (b).

AMA Consolidated Specification Questionnaire

Page 12
 Issued: 9-1-56
 Revised: 12-5-56

MAKE OF CAR Chevrolet MODEL YEAR 1957

MODEL Corvette V-8

DRIVE UNITS—CLUTCH (PEDAL OPERATED)

Make		Borg & Beck	
Type (dry or wet plate)		Dry Plate	
In combination with fluid coupling (yes, no)		No	
Semi-centrifugal (yes, no)		Yes	
Type pressure plate springs		Coil	
Total plate pressure (lb.)		1610 (Initial)	
No. of clutch driven discs		One	
Clutch facing	Material	Premium Woven Asbestos Comp.	
	Inside diameter	6.5	
	Outside diameter	10.0	
	Total eff. area (sq. in.)	90.72	
	Thickness	.132 - .138	
	Number required	Two	
	Engagement cushioning method	Springs	
	Release bearing	Type	Ball Bearing
		Method of lubrication	Sealed
	Torsional damping	Method (springs, other)	Springs at Hub
Frict. mat.		None	

DRIVE UNITS—TRANSMISSIONS

Conventional (std. or opt.)	3 Speed Standard (4 Speed Optional)
Conventional with overdrive (std. or opt.)	None
Automatic (std. or opt.)	Optional

DRIVE UNITS—CONVENTIONAL TRANSMISSION

Number of forward speeds		3	4 (Optional)
Transmission ratios	In first	2.21:1	2.20:1
	In second	1.32:1	1.66:1
	In third	Direct	1.31:1
	In fourth	None	Direct
	In reverse	2.21:1	2.25:1
Constant mesh gears in 2nd (yes, no)		Yes	Yes
Spur gear used in (indicate speeds)		None	None
Helical gears used in (indicate speeds)		All	All
Synchronous meshing in 2nd and 3rd gears (yes, no)		Yes	Yes

AMA Consolidated Specification Questionnaire

Page 13
 Issued: 9-1-56
 Revised: 12-5-56

MAKE OF CAR Chevrolet MODEL YEAR 1957

MODEL Corvette V-8

DRIVE UNITS—CONVENTIONAL TRANSMISSION (cont.)

Lubricant	Capacity (pt.)		2
	Type recommended		A-9 Mineral Oil Lubricant
	SAE viscosity number	Summer	SAE 90
		Winter	SAE 90
Extreme cold		SAE 80	

DRIVE UNITS—CONVENTIONAL TRANSMISSION WITH OVERDRIVE

For transmission data see conventional transmission section

Overdrive	Type (planetary or other)		None	
	If planetary, No. of pinions		None	
	Manual lockout (yes, no)		None	
	Downshift accelerator control (yes, no)		None	
	Minimum cut-in speed		None	
	Gear ratio		None	
	Lubricant	Capacity (O.D. only)		None
		Separate filter (yes, no)		None
		Type recommended		None
		SAE viscosity number	Summer	None
Winter	None			
Ext. cold	None			

DRIVE UNITS—AUTOMATIC TRANSMISSION

Trade name	Powerglide
Type (fluid coupling with gears, torque convertor with gears, other)	Torque Converter with Planetary Gears
Manual selector positions, left to right (show symbols and define, e.g., N- Neutral)	P - Park N - Neutral D - Drive L - Low R - Reverse
List gear ratios in each drive position (range)	Drive 1.82-1:1 Low 3.82-1.82:1 Reverse 1.82:1
Shifting within drive position range by accelerator control and speed limiting governor (yes, no)	Yes
By governor—forced shift (yes, no)	Yes
Downshift of gears in high range possible up to (mph)	50

AMA Consolidated Specification Questionnaire

Page 14
 Issued: 9-1-56
 Revised: 12-5-56

MAKE OF CAR Chevrolet MODEL YEAR 1957

MODEL Corvette V-8

DRIVE UNITS—AUTOMATIC TRANSMISSION (cont.)

Torque converter	Number of elements		3
	Max. ratio at stall at engine rpm		2.1:1
	Mechanical lockup	Provided (yes, no)	No
		Speed range	-
		Releases at (speed range, mph)	-
	Type of cooling (forced air, oil cooler and type, other)		None
Anti-creep device (yes, no)		No	
Lubricant	Capacity—refill (pt.)		11 Qts. - Refill 5 Qts.
	Type recommended		Type A
	Grade	Summer	{ Same Grade for All Temperature Ranges
		Winter	
Extreme cold			

DRIVE UNITS—PROPELLER SHAFT

Number used		1	
Type (exposed, torque tube)		Exposed Hotchkiss	
Outer diameter x length* x wall thickness	Conventional trans.	2.370 x .065 (Eff. Lgth. Varies Due to U-Joint Slip on Spline)	
	Overdrive trans.	None	
	Automatic trans.	Same as Conventional	
Intermediate bearing	Type (plain, anti-friction)	None	
	Lubri. (fitting, prepack)	None	
Universal joints	Make		Own
	Number used		2
	Type (ball and trunnion, cross, other)		Yoke and Spider (Trunnion)
	Bearing	Type (plain, anti-friction)	Anti Friction
		Lubric. (fitting, prepack)	2 Fittings
Drive taken through (torque tube or arms, spring)		Rear Springs	
Torque taken through (torque tube or arms, springs)		Rear Springs	

*Centerline to centerline of joints or centerline of rear attachment point.

AMA Consolidated Specification Questionnaire

Page 15
 Issued: 9-1-56
 Revised: 12-2-56
 12-27-56

MAKE OF CAR Chevrolet MODEL YEAR 1957

MODEL Corvette V-8

DRIVE UNITS—REAR AXLE

Type (semi-floating, other)		Semi-Floating	
Gear type (hypoid, other)		Hypoid	
Gear ratio and No. of teeth	Conventional trans.	3.70:1 (10-37) Standard; 3.70:1 (10-37) Optional; 4.11:1 (9-37) Optional; 4.56:1 (9-41) Optional (a)	
	Overdrive trans.	None	
	Automatic trans.	3.55:1 (11-39)	
Pinion adjustment (shim, other)		Shim	
Pinion bearing adj. (shim, other)		None	
Lubricant	Capacity (pt.)	4	
	Type recommended	A-9 Hypoid Lubricant	
	SAE viscosity number	Summer	SAE 90
		Winter	SAE 90
		Extreme cold	SAE 80

DRIVE UNITS—WHEELS

Type (disc, other)		Short Spoke Disc
Rim (size and flange type)		15 x 5K
Attachment	Type (bolt or stud)	Bolt
	Circle diameter	4-3/4
	Number and size	5. 7/16 x 20

DRIVE UNITS—TIRES

Size and ply rating	Standard	6.70-15-4 Ply Tubeless
	Optional	6.70-15-4 Ply White & Blackwall
Rev/mile at 30 mph		755
Inflation press. (cold)	Front	24 Lb.
	Rear	24 Lb.

BRAKES—SERVICE

Type		Servo-4 Wheel Hydraulic (Heavy Duty, Optional) (b)
Booster type		None
Effective area (sq. in.)		157 (121 with HD Brake Option)
Percent brake effectiveness—rear		44% (38% with HD Brake Option)
Drum	Diameter	Front 11
		Rear 11
	Type and material	Composite: Rim, Cast Alloy Iron; Web, Pressed Steel (c)

- (a) Optional axles equipped with positraction (limited slip) differential and extended vent lines.
- (b) - Optional heavy duty brakes available with or without air intake ducts for air cooled brakes.
- (c) - Drums, with cooling vanes cast on rim, used with heavy duty brakes option.

AMA Consolidated Specification Questionnaire

Page 16
 Issued: 9-1-56
 Revised: 12-5-56
 12-27-56

MAKE OF CAR Chevrolet

MODEL YEAR 1957

MODEL Corvette V-8

BRAKES—SERVICE (cont.)

Brake lining	Bonded or riveted		Bonded (Welded to the shoe when HD Brake Option is used)			
	Primary	Material		Full Molded Asbestos Composition (a)		
		Size (length x width x thickness)	Front wheel	9.29 x 2.0 x .175 (b)		
			Rear wheel	9.29 x 1.75 x .175 (c)		
		Segments per shoe		One		
	Secondary	Material		Full Molded Asbestos Composition (a)		
		Size (length x width x thickness)	Front wheel	11.69 x 2.0 x .175 (d)		
			Rear wheel	11.69 x 1.75 x .175 (e)		
Segments per shoe		One				
Wheel cylinder bore	Front	1.125				
	Rear	1.0 (.875 with HD Brake Option)				
Master cylinder bore		1.0				
Available pedal travel		4.50				
Line pressure at 100 lb. pedal load		700 Approx.				
Shoe clearance adjustment		Adjust to Light Drag & Back Off 7 Notches				

BRAKES—PARKING

Type of control		"T" Handle Pull Rod
Location of control		L. H. of Steering Column, Below Inst. Panel
Operates on		Rear Service Brakes
If separate from service brakes	Type (internal or external)	None
	Drum diameter	None
	Lining size (length x width x thickness)	None

FRAME

Type and description	Full length, welded, box section side and cross members "I" beam type, bracing from "X" member to frame front side member. Rear shock absorber cross member of "U" type. "T" beam type "X" member.
----------------------	--

FRONT SUSPENSION (2)

Type and description	Unitized, Independent, Short & Long Arm
----------------------	---

- (a) - Sintered Metal & Ceramic when HD brake option is used.
- (b) - 2 piece, 2.24 x 2.50 x .185 when HD brake option is used.
- (c) - 2 piece, 2.24 x 2.00 x .185 when HD brake option is used.
- (d) - 4 piece, 2.24 x 2.50 x .185 when HD brake option is used.
- (e) - 4 piece, 2.24 x 2.00 x .185 when HD brake option is used.
- (f) - Heavy duty suspension, which includes HD front & rear springs, HD front & rear shock absorbers & HD stabilizer, optional.

AMA Consolidated Specification Questionnaire

Page 17

Rev. 8-53

Issued: 9-1-56
Revised: 12-5-56
12-27-56

MAKE OF CAR Chevrolet MODEL YEAR 1957

MODEL CORVETTE

FRONT SUSPENSION (cont.)

	Type		Coil
	Material		Chrome Alloy Steel
Spring	Size (length x width x No. leaves or coil I.D.)		13.45 Free Length x 3.162 Total Number of Coils 9.75
	Spring rate (lb. per in.)		300 (550 with Optional HD Front Springs) (f)
	Rate at wheel (lb. per in.)		110
	Normal load (lb. @ rated length)		1145 @ 9.62
Shock absorbers	Manufacturer		Dalco
	Type (direct or lever)		Direct, Double Acting, Hydraulic (f)
	Piston diameter		1.0
Stabilizer	Type (link, linkless, frameless)		Link (f)
	Material		Heat Treated Hot Rolled Carbon Steel

STEERING

Type used (Standard or optional)	Mechanical			Standard	
	Power			NA	
Wheel diameter				17.25	
Turning diameter	Outside front	Wall to wall (r. & l.)	38-1/2 Ft. Right-39 Ft. Left		
		Curb to curb (r. & l.)	36-1/2 Ft. Right-37 Ft. Left		
	Inside rear	Wall to wall (r. & l.)	NA		
		Curb to curb (r. & l.)	NA		
Inside wheel angle with outside wheel at 20°				23°	
Mechanical	Gear	Type	Semi-Reversible, Hour Glass Worm and Ball Bearing Roller Sector		
		Make	Saginaw		
		Ratios	Gear	21.0:1	
			Overall	21.0:1 (16.3:1 OPTIONAL)	
	No. wheel turns		3.7 LOCK TO LOCK (3.25 OPTIONAL)		
Power	Gear	Type	None		
		Make	None		
		Trade name	None		
	Ratios	Type	None		
		Gear	None		
		Overall	None		
	Pump driven by		None		
	Overall torque ratio		None		
	Number wheel turns		None		
	Linkage	Type		Center Point	
Location (front or rear of wheels)		Rear of Wheels			
Tie rods (one or two)		Longitudinal-Two			

(f) - Heavy duty suspension, which includes HD front & rear springs, HD front & rear shock absorbers, & HD stabilizer, optional.

and quick steering adapter → QUICK STEERING ADAPTER.

AMA Consolidated Specification Questionnaire

Page 18
 Issued: 9-1-56
 Revised: 12-5-56
 12-27-56

MAKE OF CAR Chevrolet MODEL YEAR 1957

MODEL Corvette V-8

STEERING (cont.)

Kingpin	Inclination at camber (deg.)		3° 30' - 4° 30'	
	Diameter		.8660 - .8665	
	Bearings (type)	Upper		Bushing
		Lower		Bushing
Thrust			Single Row Ball	
Wheel alignment (range and preferred)	Caster (deg.)		0 - 1°	
	Camber (deg.)		0 - 1°	
	Toe-in (outside tread-inches)		0 - .125	
Steering knuckle type			Reverse Elliott	
Wheel spindle	Diameter	Inner bearing	1.2810 - 1.2815	
		Outer bearing	.7498 - .7503	
	Thread size		3/4 - 20	
	Bearing type		Ball	

REAR SUSPENSION (f)

Type	Longitudinal Springs				
Drive and torq. taken through (see page 14)	Rear Springs				
Spring	Type	Semi-Elliptic			
	Material	Alloy Steel			
	Size (length x width x No. leaves or coil I.D.)	51.0 x 2.0 x 4			
	Spring rate (lb. per in.)	115 (145 with Optional HD Rear Springs) (f)			
	Rate at wheel (lb. per in.)	NA			
	Normal load (lb. at rated length)	725			
	Mounting insulation type		Rubber Bushed		
	If leaf	No. of leaves	4		
		Covers (yes, no)	No		
		Lubricated (yes, no)	No		
		Inserts	Type and size	3 Liners; 19.8 x 1.9 x .10; 31.8 x 1.9 x .10; 46.3 x 1.9 x .10	
			Material	Wax Impregnated Fibre Board	
	Shackle (comp. or tens.)		In Tension From Rear Hanger		
Shock absorbers	Manufacturer	Delco			
	Type (direct or lever)	Direct, Double Acting, Hydraulic (f)			
	Piston diameter	1.0			
Stabilizer	Type (link, linkless, frameless)	None			
	Material	None			
Track bar type		None			

(f) - Heavy duty suspension, which includes HD front & rear springs, HD front & rear shock absorbers & HD stabilizer, optional.

AMA Consolidated Specification Questionnaire

Page 19

Rev. 8-53

Issued: 9-1-56

Revised: 12-5-56

MAKE OF CAR Chevrolet MODEL YEAR 1957

BODY—GENERAL DEFINITIONS

NOTE: Included in the dimension definitions listed on this and the following pages are those which have been proposed for adoption by the SAE. These are indicated by a number following the type of dimension, e.g., L 3. Additional dimensions have been added by the AMA Specifications Body Sub-Committee for inclusion in the Questionnaire. These are shown by an additional letter, e.g., HA. The dimensions are developed from the following basic points:

1. Front and rear seat "A" points are taken 5" forward of vertical tangent to seat back 15" from center of body.
2. Front seat is in the rear position.
3. Loaded position—5 passengers, front 300 lb., rear 450 lb., includes spare wheel, tire and tools, and full complement of gas, oil, water, etc. and tires to recommended pressure, etc.
4. C. L. (centerline).
5. D. L. O. (daylight opening, exposed glass dimension).
6. Ramp breakover angle (page 20-A) is the supplement of the included ramp angle (180° minus the included ramp angle) over which a car can pass without hanging up.

MODEL

Corvette

V-8

BODY—TRUNK OPENING DIMENSIONS

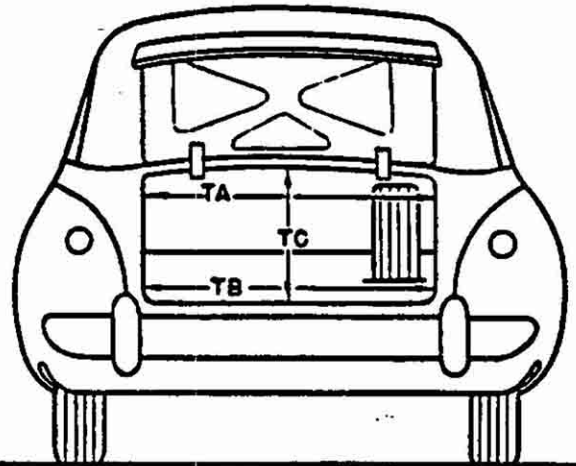
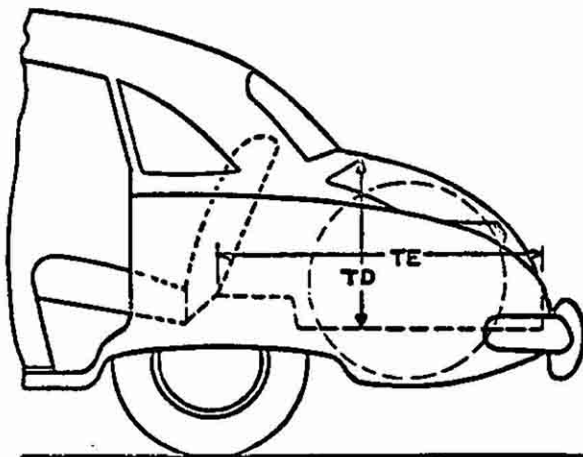

TA—Width across the top	45.0
TB—Width across the bottom	40.0
TC—Diagonal dimension at CL from top of opening to bottom	NA
TD—Vertical height of opening (floor to top, inside edge of opening)	14.2
TE—Max. horizontal depth (forward from vertical projection of inside edge of opening)	31.0
Position of spare tire stowage	Horizontal in Floor Tire Well Under Mat
Method of holding lid open	Counterbalance Springs

AMA Consolidated Specification Questionnaire

MAKE OF CAR Chevrolet MODEL YEAR 1957

MODEL Corvette V-8

BODY—HEIGHT DIMENSIONS—INTERIOR

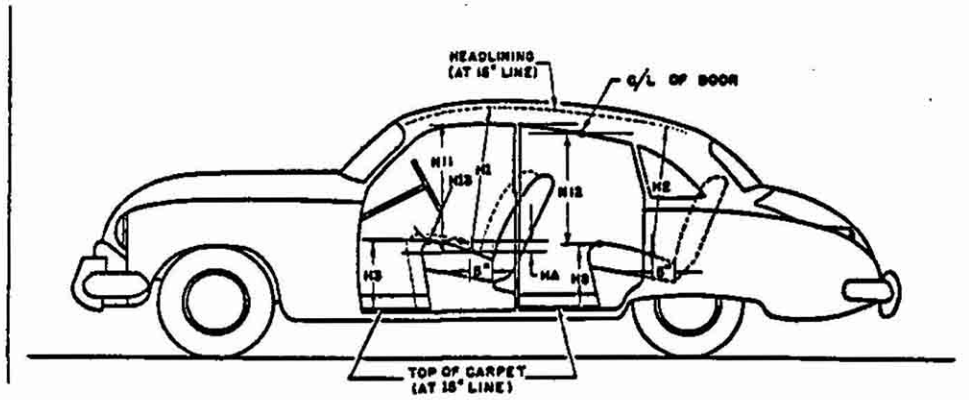

H1. Front headroom—from "A" pt. to headlining at 8° back of vertical on 15" line. (For "A" pt. see note 1, page 19)	34.3
H2. Rear headroom—from "A" pt. to headlining at 8° back of vertical on 15" line.	Not Applicable
H3. Front seat height to floor carpet on 15" line (front edge of cushion).	8.9
H8. Rear seat height to floor carpet on 15" line (front edge of cushion).	Not Applicable
H11. Entrance—front—cushion "A" point to bottom windcord vertical.	28.0
H12. Entrance—rear—top of cushion to bottom windcord vertical at C/L of rear door.	Not Applicable
H13. Steering wheel clearance to seat cushion taken on arc.	4.8
HA. Front seat vertical rise at "A" pt. (inches.)	.22

AMA Consolidated Specification Questionnaire

Page 20-A

Issued: 9-1-56
Rev. 8-53
Revised: 12-5-56

MAKE OF CAR Chevrolet

MODEL YEAR 1957

V-8

MODEL Corvette

BODY—HEIGHT DIMENSIONS—EXTERIOR

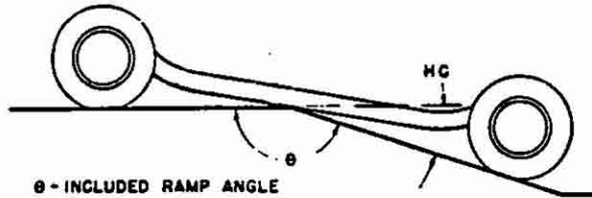
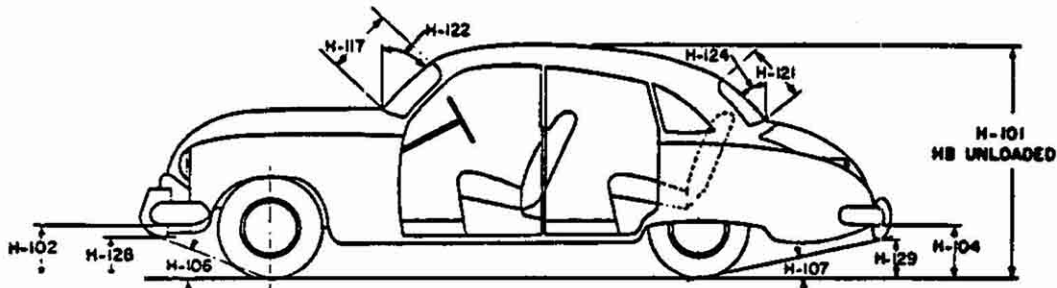

θ - INCLUDED RAMP ANGLE
HC - RAMP BREAKOVER ANGLE
(SUPPLEMENT OF INCLUDED RAMP ANGLE)

H101. Overall height.	51.1
H3. Overall height—unloaded.	52.0
H102. Front bumper bottom to ground at normal section.	9.3
H104. Rear bumper bottom to ground at normal section.	14.7
H106. Angle of approach—from the tire rolling radius to lowest point on front bumper or guard.	28° 1'
H107. Angle of departure—from the tire rolling radius to lowest point on rear bumper or guard.	18° 50'
HC. Ramp breakover angle.*	14° 54'
H117. Windshield DLO—slant height.	17.3
H121. Backlight DLO*—Max., slant height.	11.5
H122. Windshield slope angle to vertical line on car axis.	50°
H124. Backlight slope angle to vertical line on car axis.	NA
H128. Ground to bottom of front bumper guard.	See H102
H129. Ground to bottom of rear bumper guard.	See H103
HD. Min. road clearance (location and dimension).	Body Sill-5.81
HE. Min. road clearance at rear axle.	8.00

*See Notes, page 19.

AMA Consolidated Specification Questionnaire

Page 21
 Issued: 9-1-54
 Revised: 12-5-54

MAKE OF CAR Chevrolet MODEL YEAR 1957

MODEL Corvette V-8

BODY—LENGTH DIMENSIONS

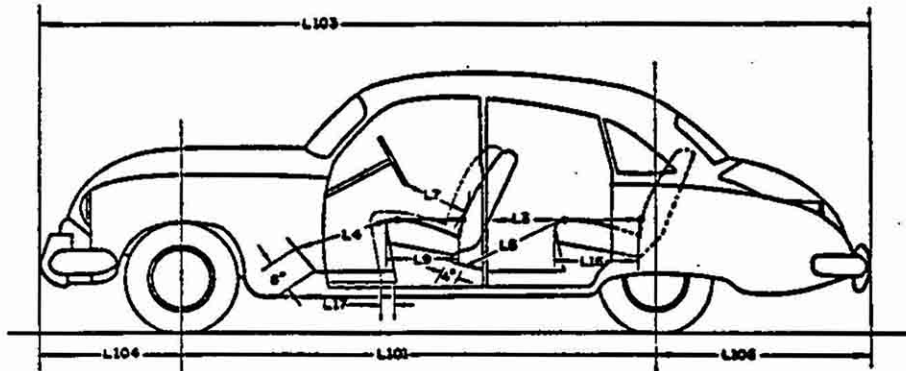

	L3. Rear compartment back of front seat back to rear seat back.	Not Applicable
	L4. Leg room—front—diagonal—ball of foot to top of seat to front seat back—15° line.	44.2
	L5. Leg room—rear—diagonal—from ball of foot to top of rear seat cushion and to seat back.	Not Applicable
Interior	L7. Steering wheel clearance to seat back taken on arc.	13.5
	L9. Front seat depth (front edge to vert. tan. to seat back on 15° line).	18.2
	L16. Depth of rear seat (front edge to seat back).	Not Applicable
	L17. Total adjustment of front seat at floor.	4.4
	L101. Wheel base.	102.0
	L103. Overall length (bumper to bumper inc. guards).	168.0
Exterior	L104. Overhang—front including bumper guards.	21.7
	L105. Overhang—rear including bumper guards.	17.1

AMA Consolidated Specification Questionnaire

Page 22
 Issued: 9-1-56
 Revised: 12-5-56

MAKE OF CAR Chevrolet MODEL YEAR 1957

MODEL Corvette V-8

BODY—WIDTH DIMENSIONS

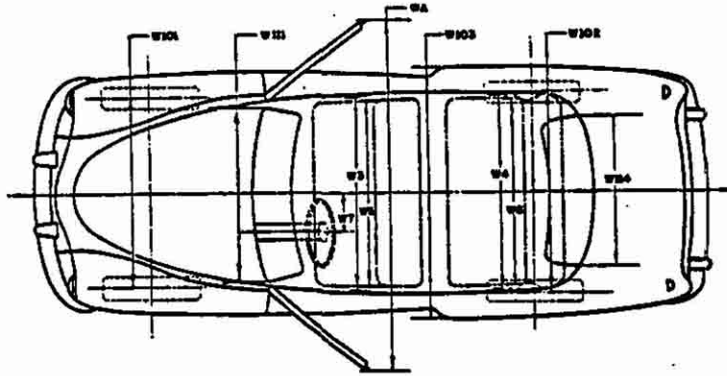

	W3. Front shoulder room, at garnish moulding height or nearest interference 5" forward of seat back.	51.3
Interior	W4. Rear shoulder room, at garnish moulding height or nearest interference 5" forward of seat back.	Not Applicable
	W5. Front hip room, at top of seat 5" forward of vert. tan. to seat back.	50.5
	W6. Rear hip room, at top of seat 5" forward of vert. tan. to seat back.	Not Applicable
	W7. Steering wheel center to center of body.	13.8
	W101. Front tread at ground.	57.0
	W102. Rear tread at ground.	59.0
Exterior	W103. Max. overall width of car including bumpers or mouldings.	70.5
	WA. Max. overall width of car with doors open.	NA
	W111. Windshield DLO, max. width.	53.6
	W114. Back window DLO, max. width.	31.3

AMA Consolidated Specification Questionnaire

MAKE OF CAR Chevrolet MODEL YEAR 1957

MODEL Corvette V-8

BODY—MISCELLANEOUS INFORMATION

Doors hinged (front, rear)	Front	Front
	Rear	Not Applicable
Type of finish (lacquer, enamel)		Lacquer
Hood opening (front, side; semi-full, full, half)		Front - Reverse Alligator
Hood counterbalanced (yes, no)		No
Hood release control (internal, external)		Internal
Vent window control method (crank, friction, pivot).		Pivot
Windshield (one piece, two piece; curved, flat)		One Piece Curved
Rear window type (one piece, two piece, three piece; curved, flat)		Convertible Top - One Piece Flat (Plastic) (Hardtop) - One Piece Curved (Optional)
Windshield glass area		908 sq. in.
Backlight glass area		408 sq. in.
Total glass area		1816 sq. in.

BODY—TYPES AND STYLE NAMES

Body type, number of passengers, and style names (use letter code shown below followed by passenger capacity and style name e.g., N-6 Ranchwagon)	L-2 *

Body type code

- | | |
|--|---|
| A—Coupe—2 door flatback
B—Coupe—2 door notchback
C—Sedan—2 door flatback
D—Sedan—2 door notchback
E—Sedan—4 door flatback (4 windows)
F—Sedan—4 door flatback (6 windows)
G—Sedan—4 door notchback (4 windows)
H—Sedan—4 door notchback (6 windows)
J—Hardtop—2 door
K—Hardtop—4 door | L—Convertible—2 door
M—Convertible—4 door
N—Station wagon—2 door
P—Station wagon—4 door
Q—Combined passenger and utility—2 door
R—Combined passenger and utility—4 door
S—Sedan delivery
T—Limousine
* - Removable Hardtop—Optional Equipment |
|--|---|